

XO5080 Series

1x1 inch, 5.0 Volt, HCMOS or Sinewave, OCXO



- Surface mount package offering both AT and SC-cut crystals
- Ideal for microwave radios (short haul), base stations, and test equipment applications where size and package style (SMT) are critical

Model XO5080	Frequency (MHz)	Temperature Range (°C)	Temperature Stability	Aging First Year	Output	Supply Voltage
SC-Cut	10	0 to +70	$\pm 1 \times 10^{-8}$	$\pm 1.5 \times 10^{-7}$	Sinewave/HCMOS	5 Vdc $\pm 5\%$
AT-Cut	10	0 to +70	$\pm 5.0 \times 10^{-8}$	$\pm 2.0 \times 10^{-7}$	Sinewave/HCMOS	5 Vdc $\pm 5\%$
Options	3 to 100	-45 to +85	Consult Factory		Sinewave/HCMOS	5-15 Vdc

Additional Specifications

Aging Daily	$< \pm 5 \times 10^{-10}$ for SC-cut	$\pm 1 \times 10^{-9}$ for AT-cut
Power Consumption	1.25 watt @ 25°C steady state	
Warm-up power	4.0 watt	
Warm-up time @ 25°C	To within $\pm 1 \times 10^{-7}$ of Fo in 2 min	
Frequency Adjustment	$\pm 2 \times 10^{-6}$ SC	$\pm 4 \times 10^{-6}$ AT
Voltage Control	0 to 4 V	
Slope	Positive	
Reference Output	3.9 V	
Sine output level	3dBm to 7dBm ± 3 dBm	

Phase Noise at 10 MHz	(SC-cut)	(AT-cut)
1 Hz	-90 dBc/Hz	-80 dBc/Hz
10 Hz	-120 dBc/Hz	-115 dBc/Hz
100 Hz	-140 dBc/Hz	-140 dBc/Hz
1 kHz	-145 dBc/Hz	-145 dBc/Hz
10 kHz	-145 dBc/Hz	-145 dBc/Hz

Optional Models		
	Xtal	Output
5081	AT	Sine
5082	AT	HCMOS
5083	SC	Sine
5084	SC	HCMOS

Dimensions are in inches (mm)

PIN CONNECTIONS	
1.	RF OUTPUT
2.	N/C
4.	CASE GROUND & SUPPLY RETURN
6.	N/C
7.	FREQUENCY ADJUST OR Vref
13.	Vref (OPTIONAL)
15.	N/C
17.	OVEN READY (OPTIONAL)
19.	SUPPLY (+)

Pin numbers shown for ref. only.
Numbers are not marked on unit.

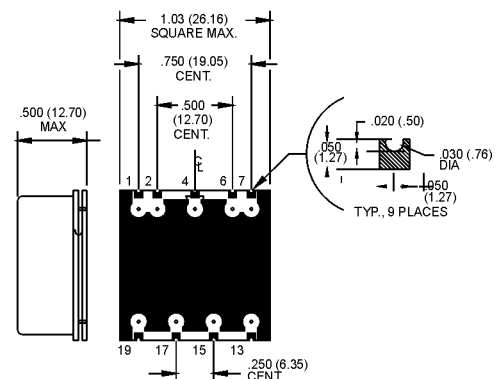
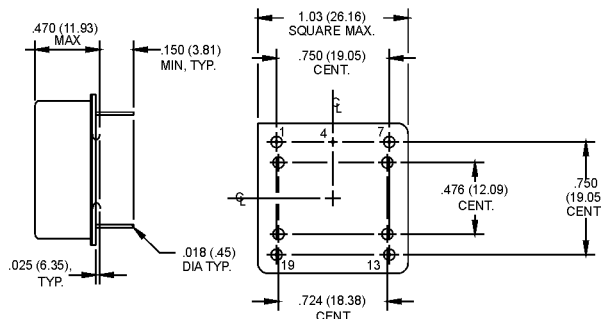
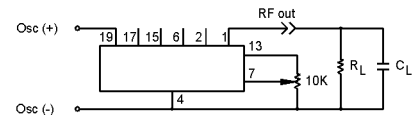

MtronPTI reserves the right to make changes to the product(s) and service(s) described herein without notice. No liability is assumed as a result of their use or application.

Please see www.mtronpti.com for our complete offering and detailed datasheets. Contact us for your application specific requirements: MtronPTI 1-800-762-8800.