

# HDM16216L-S

## Dimensional Drawing

16 Character x 2 Lines, Very Small Size, LED Backlight

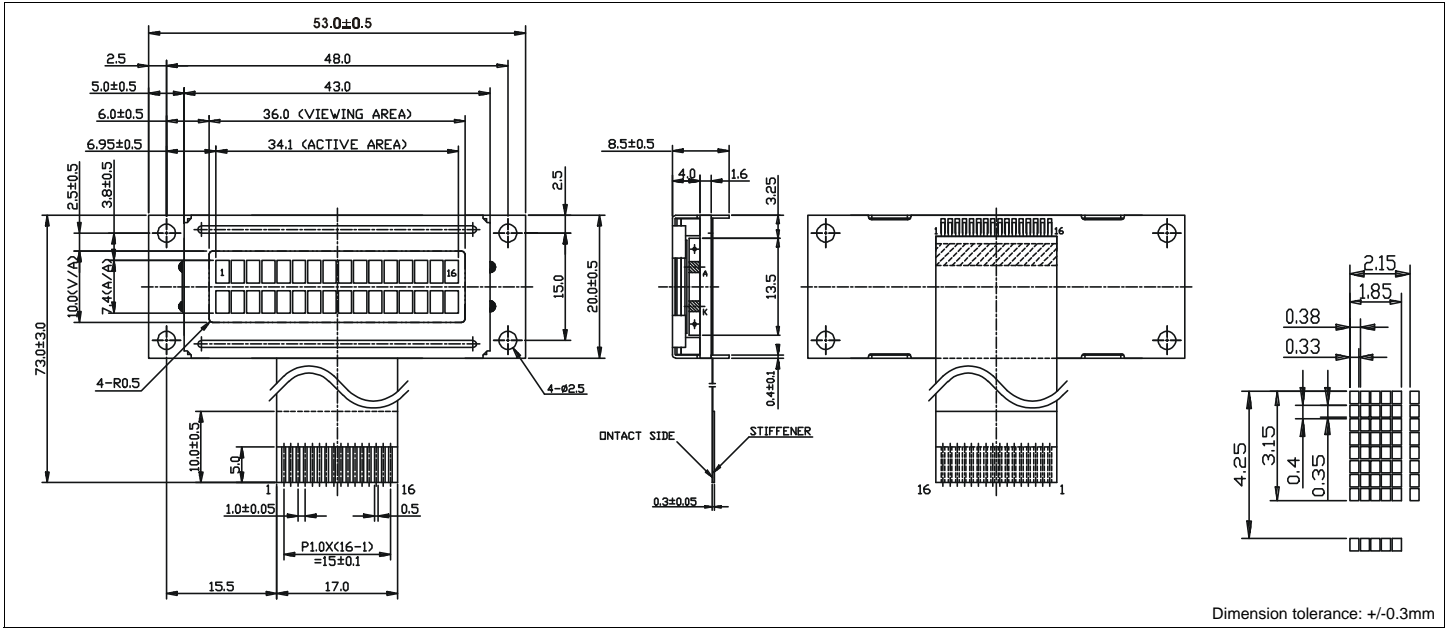

### Features

Character Format .....5x7 Dots with Cursor  
 Backlight.....LED  
 Options.....Yellow STN, 6 o'Clock View  
 Normal/Extended Temperature  
 Normal/Negative Displays

### Physical Data

Module Size.....53.0W x 20.0H x 8.5T mm  
 Viewing Area Size.....36.0W x 10.0H mm  
 Weight.....10g

### Absolute Maximum Ratings

PARAMETER	SYMBOL	MIN	MAX	UNIT
SUPPLY VOLTAGE	$V_{DD}-V_{SS}$	0	7.0	V
SUPPLY VOLTAGE FOR LCD	$V_{DD}-V_L$	0	13.5	V
INPUT VOLTAGE	$V_{IN}$	0	$V_{DD} + 0.3$	V
OPERATING TEMPERATURE	$T_{OP}$	0	50	°C
STORAGE TEMPERATURE	$T_{STG}$	-20	70	°C
LED FORWARD CURRENT	$I_F$	-	40	mA
LED REVERSE VOLTAGE	$V_R$	-	8	V
LED POWER CONSUMPTION	$P_D$	-	220	mW

### Electrical Characteristics (VDD=5.0±0.25V 25°C)

PARAMETER	SYM	CONDITION	MIN	TYP	MAX	UNIT
INPUT HIGH VOLTAGE	$V_{IH}$	-	2.2	-	$V_{DD}$	V
INPUT LOW VOLTAGE	$V_{IL}$	-	$V_{SS}$	-	0.6	V
OUTPUT HIGH VOLTAGE	$V_{OH}$	$I_{OH}=0.2mA$	2.4	-	$V_{DD}$	V
OUTPUT LOW VOLTAGE	$V_{OL}$	$I_{OL}=1.2mA$	$V_{SS}$	-	0.4	V
POWER SUPPLY CURRENT	$I_{DD}$	$V_{DD}=5.0V, V_L=4.4V$	-	1.0	2.0	mA
POWER SUPPLY FOR LCD	$V_{DD}-V_L$	$T_A=25°C$	-	4.4	-	V
LED FORWARD VOLTAGE	$V_F$	$I_F=20mA$	-	4.2	-	V
BRIGHTNESS	L	$V_F=4.2V, I_F=20mA$	7	10	-	NIT
DRIVE METHOD	1/16 Duty					

### Block Diagram

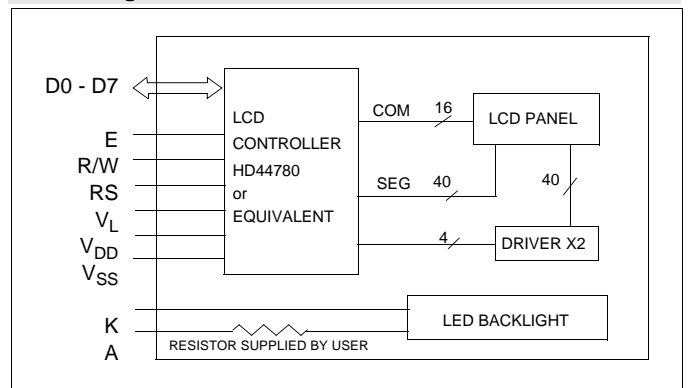

### Pin Connections

PIN NO.	SYMBOL	LEVEL	FUNCTION
1	$V_{SS}$	-	Power supply
2	$V_{DD}$	-	
3	$V_L$	-	
4	RS	H/L	H: Data input L: Instruction data input
5	R/W	H/L	H: Data read L: Data write
6	E	H,H→L	Enable signal
7	D0	H/L	Data bus
8	D1	H/L	
9	D2	H/L	
10	D3	H/L	
11	D4	H/L	
12	D5	H/L	
13	D6	H/L	
14	D7	H/L	
15	A		Anode for LED back light
16	K		Cathode for LED back light