

GENERAL PURPOSE RECTIFIERS

82 DE 0258354 0000035 0

0258354 ADVANCED SEMICONDUCTOR

82D 00035

D T-01-01

T.25.01

IO AVERAGE RECTIFIED FORWARD CURRENT (AMPERES)

VRRM	3	3	5	6	6	6	12	15	20	20	25	25
50	MR500	IN5400	IN1612	IN1341A		MR750	IN1199A	IN3208	IN248B	IN1191A	IN2154	IN3491
100	MR501	IN5401	IN1613	IN1342A		MR751	IN1200A	IN3209	IN249B	IN1192A	IN2155	IN3492
150				IN1343A			IN1201A			IN1193A		
200	MR502	IN5402	IN1614	IN1344A		MR752	IN1202A	IN3210	IN250B	IN1194A	IN2156	IN3493
300				IN1345A			IN1202A			IN1195A	IN2157	
400	MR504	IN5404	IN1615	IN1346A		MR704	IN1204A	IN3212		IN1196A	IN2158	IN3495
500				IN1347A			IN1205A			IN1197A	IN2159	
600	MR506	IN5406	IN1616	IN1348A		MR756	IN1206A	IN3214		IN1198A	IN2160	
700												
800	MR508	IN5407			IN3987	MR758	IN3670A					
900					IN3988		IN3671A					
1000	MR510	IN5408			IN3989	MR760	IN3672A					
1200					IN3990		IN3673A					
IFSM	100	200		150	50	400	IN5331					300
VFM	1	1.2	1.5	1.4	1.5	1.25	300	250	600	350	400	300
CASE	A1	A1	D04	D04	D04	A2	D04	D04	D05	D05	D05	D021

Available in "R" - REVERSE POLARITY versions.

FAST RECOVERY RECTIFIERS

SCHOTTKY RECTIFIERS

VRRM (VOLTS)	IO AVERAGE RECTIFIED FORWARD CURRENT (AMPERES)				
	5	6	12	20	30
50	MR820	IN3879	IN3889	IN3899	IN3909
100	MR821	IN3880	IN3890	IN3900	IN3910
200	MR822	IN3881	IN3891	IN3901	IN3911
400	MR824	IN3883	IN3893	IN3903	IN3913
600	MR826				
800					
1000					
IFSM (Amps)	300	150	200	250	300
VFM	1	1.5	1.5	1.5	1.5
tRR (us)	.2	.2	.2	.2	.2
	A2	D04		D05	

VRRM (VOLTS)	IO AVERAGE RECTIFIED FORWARD CURRENT (AMPERES)				
	15	25	40	50	
20	IN5826	IN5829		IN5832	
30	IN5827	IN5830	IN6095	IN5833	IN6097
35					
40	IN5828	IN5831	IN6096	IN5834	IN6098
45			SD41		SD51
IFSM (Amps)	500	800	400	800	800
VFM	.5	.48	.86	.59	.86
		D04		D05	

SILICON CONTROLLED RECTIFIERS

ON-STATE (RMS) CURRENT AMPERES

VDRM VRRM	.5	.8	1.6	1.6	1.6	1.6	4	4	7.4	8	8	8
25	2N877	2N5060		C6U	2N2322	2N2344	2N6236	C106Y1	2N1770			C15U
50	2N878	2N5061	2N1595	C6F	2N2323	2N2345	2N6237	C106F1	2N1771	2N4441T	C122F	C15F
100	2N897	2N5062	2N1596	C6A	2N2324	2N2346	2N6238	C106A1	2N1772		C122A	C15A
200	2N881	2N5064	2N1597	C6B	2N2326	2N2348	2N6239	C106B1	2N1774	2N4442T	C122B	C15B
300			2N1598	C6C	2N2328			C106C1	2N1776		C122C	C15C
400			2N1599	C6D	2N2329		2N6240	C106D1	2N1777	2N4443T	C122D	C15D
500								C106E1	2N1778		C122E	C15E
600							2N6241	C106M1	2N2619	2N4444T	C122M	C15M
IGT (MA)	.2	.2	10	1	.2	.2	.2	.2	15	30	25	25
VGT	.8	.8	3	.8	.8	.8	1	.8	2	1.5	1.5	2.5
CASE TYPE	T018	T092	T039	T039	T039	T039	T0126	T0202	T064	T0220	T0220	T064

GENERAL PURPOSE RECTIFIERS

0258354 ADVANCED SEMICONDUCTOR

82D 00036

D T-01-01

T. 25.01

10 AVERAGE RECTIFIED FORWARD CURRENT (AMPERES)

30	35	35	40	100	100	160
IN3659 IN3660	IN1183 IN1184 IN1185 IN1186		IN1183A IN1184A IN1185A IN1186A			IN3260 IN3261
IN3661	IN1186		IN1187A IN1188A IN1189A IN1190A	IN3289	IN3289A	IN3263
IN3663	IN1187 IN1188 IN1189 IN1190		IN1187A IN1188A IN1189A IN1190A	IN3290 IN3291 IN3292 IN3293	IN3290A IN3291A IN3292A IN3293A	IN3265 IN3267 IN3268 IN3269
		IN3765 IN3766 IN3767 IN3768		IN3294	IN3294A	IN3270 IN3271 IN3272 IN3273
				IN3295	IN3295A	
400 1.2 D04	500 1.7 D05	500 1.8 D05	800 1.2 D05	1600 1.5 D08	2300 1.25 D08	2000 1.6 D09

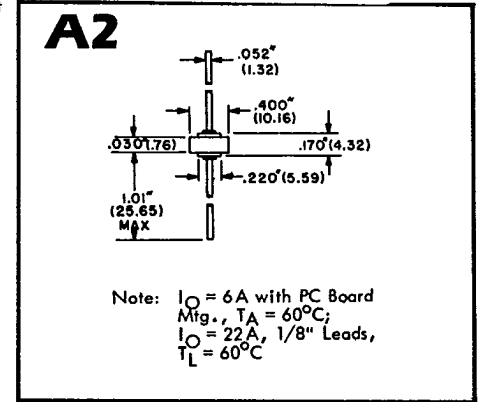
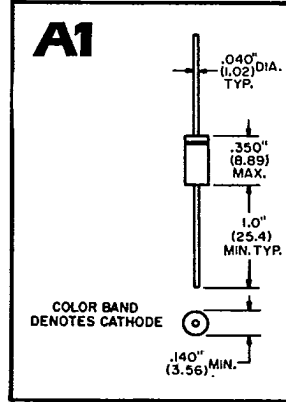

All Outline Drawings Conform to JEDEC and EIA Specifications

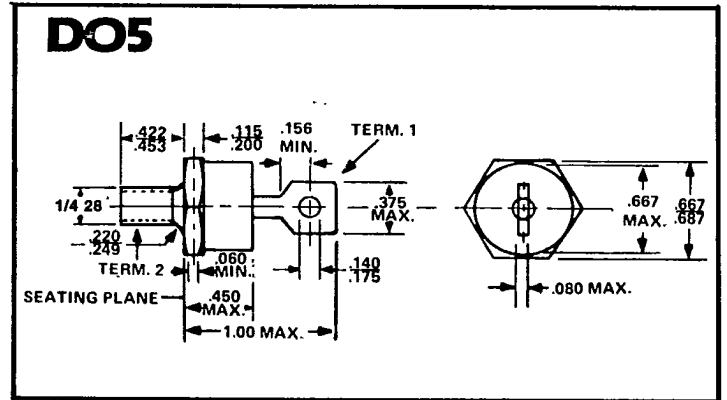
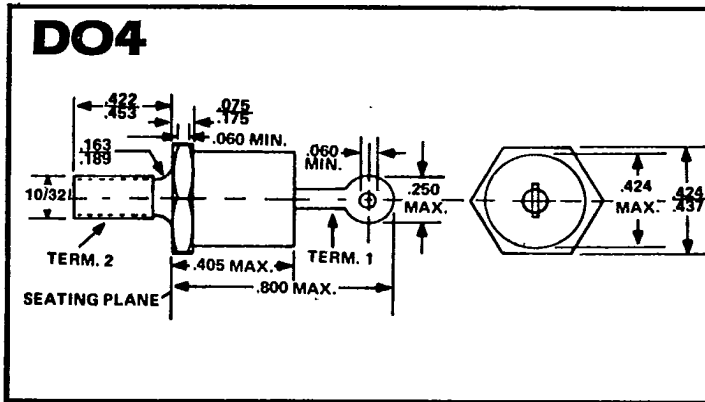

CONTINUED NEXT PAGE

SILICON CONTROLLED RECTIFIERS

ON-STATE (RMS) CURRENT AMPERES

VDRM VRRM	8	10	12	16	16	20	25	25	35	35	35	35
25	2N4167	C220F	2N6394	2N6400	2N1842	2N5164	2N681	C37U			C35U	C38U
50	2N4168	C220F	2N6395	2N6401	2N1843		2N682	C37F			C35F	C38F
100	2N4169	C220A	2N6395	2N6401	2N1844		2N683	C37A	2N3870		C35A	C38A
200	2N4170	C220B	2N6396	2N6402	2N1846	2N5165	2N685	C37B	2N3871		C35B	C38B
300	2N4171	C220C			2N1848		2N687	C37C			C35C	C38C
400	2N4172	C220D	2N6397	2N6403	2N1849	2N5166	2N688	C37D	2N3872		C35D	C38D
500	2N4173	C220E			2N1850		2N689	C37E			C35E	C38E
600	2N4174	C220M	2N6398	2N6404		2N5167	2N690	C37M	2N3873	2N5204	C35M	
700							2N691	C37S			C35S	
800							2N692	C37N		2N5205		
900										2N5206		
1000												
1100												
1200										2N5207		
IGT (MA)	30	25	30	30	80	25	25	80	40	40	40	40
VGT	1.5	.2	1.5	1.5	2	2.5	3	3.5	3	3	3	3
CASE TYPE	T064	T048	T0220	T0220	T048	T048	T048	T048	T0203	T048	T048	T048

SILICON CONTROLLED RECTIFIERS CONTINUED NEXT PAGE

SILICON CONTROLLED RECTIFIERS

ADVANCED SEMICONDUCTOR

82 DE 0258354 0000037 3

7-25-01

ON-STATE (RMS) CURRENT AMPERES

VDRM VRRM	35	63	80	80	110	110	110	110	110	110	190	400
25	C137U	C147U	C45U	C46U	2N1909	C52U	C150U	C152U	C60U	C62U		
50	C137F	C147F	C45F	C46F	2N1910	2N1792	C150F	C152F	C60F	C62F		
100	C137A	C147A	C45A	C46A	2N1911	2N1793	C150A	C152A	C60A	C62A		C380A
200	C137B	C147B	C45B	C46B	2N1913	2N1795	C150B	C152C	C60B	C62B		C380B
300	C137C	C147C	C45C	C46C	2N1915	2N1797	C150C	C152C	C60C	C62C		C380C
400	C137D	C147D	C45D	C46D	2N1916	2N1798	C150D	C152D	C60D	C62D		C380D
500	C137E	C147E	C45E	C46E	C50E	C52E	C150E	C152E	C60E	C62E	C350E	C380E
600	C137M	C147M	C45M	C46M	C50M	C52M	C150M	C152M			C350M	C380M
700	C137S	C147S	C45S	C46S	C50S	C52S	C150S	C152S			C350S	C380S
800	C137N	C147N	C45N	C46N	C50N	C52N	C150N	C152N			C350N	C380N
900	C137T	C147T	C45T	C46T	C50T	C52T	C150T	C152T			C350T	C380T
1000	C137P	C147P	C45P	C46P	C50P	C52P	C150P	C152P			C350P	C380P
1100	C137PA	C147PA	C45PA	C46PA	C50PA	C52PA	C150PA	C152PA			C350PA	C380PA
1200	C137PB	C147PB	C45PB	C46PB	C50PB	C52PB	C150PB	C152PB			C350PB	C380PB
1300		C147PC					C150PC	C152PC			C350PC	C380PC
IGT (MA)	40	150	75	75	75	75	150	150	75	75	150	150
VGT (V)	3	3.5	3	3	3	3	3	3	3	3	3	3
CASE TYPE	T048	T065	T083	T094	T094	T083	T094	T083	T094	T083	HP1	HP1

PHYSICAL DIMENSIONS

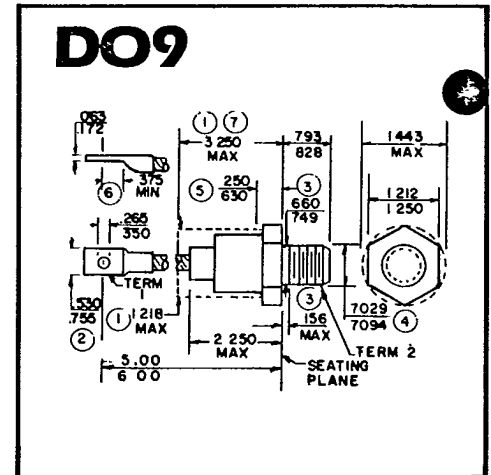
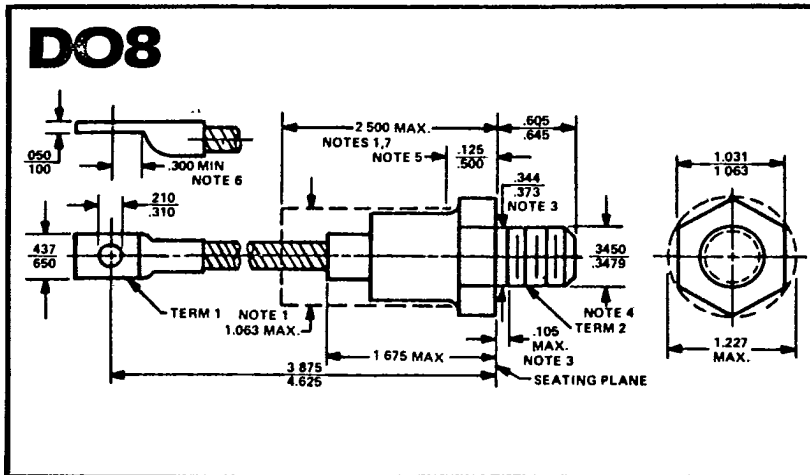

TRIACS

ON-STATE (RMS) CURRENT AMPERES

VDRM VRRM	2.5	6	6	6	6	6	6	8	8	8	8	8
25												
50	T2303F							MAC220-2	MAC221-2			
100	2N5724	T2500A	SC140A	SC141A	T2801A			MAC220-3	MAC221-3	TIC226A	T2800A	T2802A
200	2N5755	T2500B	SC140B	SC141B	T2801B	SC240B	SC241B	2N6342	2N6346	TIC226B	T2800B	T2802B
300		T2500C	SC140C	SC141C	T2801C	SC240C	SC241C	MAC220-5	MAC221-5	TIC226C	T2800C	T2802C
400	2N5756	T2500D	SC140D	SC141D	T2801D	SC240D	SC241D	2N6343	2N6347	TIC226D	T2800D	T2802D
500		T2500E	SC140E	SC141E	T2801E	SC240E	SC241E	MAC220-7	MAC221-7	TIC226E	T2800E	T2802E
600	2N5757	T2500M	SC140M	SC141M	T2801M	SC240M	SC241M	2N6344	2N6348	TIC226M	T2800M	T2802M
700		T2500S	SC140S	SC141S	T2801S	SC240S	SC241S	MAC220-9	MAC221-9	TIC226S	T2800S	T2802S
800		T2500N	SC140N	SC141N	T2801N	SC240N	SC241N	2N6345	2N6349	TIC226N	T2800N	T2802N
IGT(MA)	25	25	50	50	80	50	50	50	50	50	25	50
CASE	T039	T0220	T0220	T0220	T0220	T048	PRESS FIT	T0220	T0220	T0220	T0220	T0220

SILICON CONTROLLED RECTIFIERS

ADVANCED SEMICONDUCTOR

82 DE 0258354 000038 5

T-25-01

VDRM VRRM	800	800	900	980	1000	1000
100			C390AX500	C390AX550		
200	C390B		C390BX500	C390BX550		
300	C390C		C390CX500	C390CX550		
400	C390D		C390DX500	C390DX550		
500	C390E		C390EX500		C430E	
600	C390M		C390MX500		C430M	
700	C390S				C430S	
800	C390N				C430N	
900	C390T				C430T	
1000	C390P				C430P	
1100	C390PA				C430PA	
1200	C390PB				C430PB	
1300	C390PC	C391PC			C430PC	C431PC
1400		C391PD				C431PD
1500		C391PE				C431PE
1600		C391PM				C431PM
1700		C391PS				C431PS
1800		C391PN				C431PN
IGT (MA)	150	150	150	150	150	150
VGT (V)	5	5	5	5	5	5
	HP2	HP2	HP2	HP2	HP3	HP3

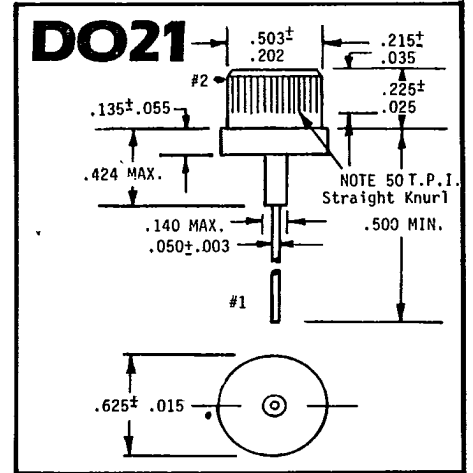

All Outline Drawings Conform to JEDEC and EIA Specifications

HP1 TABLE OF DIMENSIONS

Conversion Table

SYM	DECIMAL INCHES		METRIC MM	
	MIN.	MAX.	MIN.	MAX.
A	.240	.260	6.223	6.604
B	.110	.140	3.048	3.556
C	.245	-	6.223	-
D	.186	.189	4.724	4.801
E	.060	.075	1.524	1.905
F	-	1.125	-	28.550
G	-	.865	-	21.946
H	1.600	1.656	40.640	42.06
J	.011	.019	2.794	3.483
K	.030	.060	.762	1.524
L	.056	.060	1.422	1.524
M	.515	.565	13.081	14.351
N	.030	.060	.762	1.524
P	.135	.150	3.429	3.810
Q	.740	.760	18.897	19.101
R	-	1.460	-	37.080
S	.067	.083	1.701	2.108
T	7.980	-	202.900	-
U	.137	.153	3.479	3.886

HP2 TABLE OF DIMENSIONS

Conversion Table

SYM	DECIMAL INCHES		METRIC MM	
	MIN.	MAX.	MIN.	MAX.
A	.240	.260	6.096	6.604
B	.110	.140	2.794	3.302
C	.245	-	6.223	-
D	.186	.191	4.724	4.851
E	.060	.075	1.524	1.905
F	-	1.430	-	36.320
G	-	1.065	-	27.051
H	2.200	2.500	55.880	63.500
J	.011	.019	2.794	3.483
K	.030	.130	.762	3.302
L	.056	.060	1.422	1.524
M	1.000	1.070	25.400	27.180
N	.030	.130	.762	3.302
P	.130	.150	3.302	3.810
Q	1.300	1.345	33.02	34.160
R	-	2.150	-	54.61
S	.067	.803	1.702	2.110
T	12.200	-	309.900	-
U	.137	.153	3.480	3.886

HP3 TABLE OF DIMENSIONS

Conversion Table

SYM	DECIMAL INCHES		METRIC MM	
	MIN.	MAX.	MIN.	MAX.
A	.240	.260	6.096	6.604
B	.110	.140	2.794	3.302
C	.245	-	6.223	-
D	.186	.191	4.724	4.851
E	.060	.075	1.524	1.905
F	-	1.740	-	44.200
G	-	1.350	-	34.29
H	-	2.960	-	75.18
J	.017	.023	.430	.570
K	.050	.130	1.270	3.302
L	.057	.060	1.422	1.524
M	1.000	1.070	25.400	27.180
N	.050	.130	1.270	3.302
P	.135	.150	3.429	3.810
Q	1.700	1.900	43.180	48.260
R	-	2.650	-	67.31
S	.070	.100	1.770	2.540
T	12.200	-	309.900	-
U	.137	.153	3.480	3.886

TRIACS

8	10	10	10	10	12	12	12	15	15	15	25	30	30	40
SC143B	SC146B	SC246B	SC245B	T4121B	2N6342A	2N6346A	SC149B	SC251B	SC250B	T4120B	SC260B	2N6160	2N6163	2N5444
SC143C	SC146C	SC246C	SC245C	T4121C			SC149C	SC251C	SC250C	T4120C	SC260C			
SC143D	SC146D	SC246D	SC245D	T4121D	2N6343A	2N6347A	SC149D	SC251D	SC250D	T4120D	SC260D	2N6161	2N6164	2N5445
SC143E	SC146E	SC246E	SC245E	T4121E			SC149E	SC251E	SC250E	T4120E	SC260E			
SC143M	SC146M	SC246M	SC245M	T4121M	2N6344A	2N6348A	SC149M	SC251M	SC250M	T4120M	SC260M	2N6162	2N6165	2N5446
SC143S	SC146S	SC246S	SC245S				SC149S	SC251S	SC250S	T4120S	SC260S			
SC143N	SC146N	SC246N	SC245N		2N6345A	2N6349A	SC149N	SC251N	SC250N	T4120N				
50	50	50	50	100	50	50	50	100	100	100	50	70	70	70
T0220	T0220	Consult Factory	Consult Factory	T048 ISOLATED	T0220	T0220	T022	Consult Factory	T048	T048 ISOLATED	Consult Factory	T048	T048 ISOLATED	T048