

**QUAD BIPOLAR OPERATIONAL AMPLIFIERS**

- LOW DISTORTION RATIO
- LOW NOISE
- VERY LOW SUPPLY CURRENT
- LOW INPUT OFFSET CURRENT
- VERY LOW INPUT OFFSET VOLTAGE
- LARGE COMMON-MODE RANGE
- HIGH GAIN
- HIGH OUTPUT CURRENT
- GAIN-BANDWIDTH PRODUCT : 2.5MHz
- TEMPERATURE DRIFT : 2μV/°C
- LONG TERM STABILITY : 8μV/YEAR  
(for T<sub>amb</sub> ≤ 50°C)
- THE TEB4033 AND TEF4033 ARE PIN TO PIN REPLACEMENT OF THE LS204C AND LS204I RESPECTIVELY

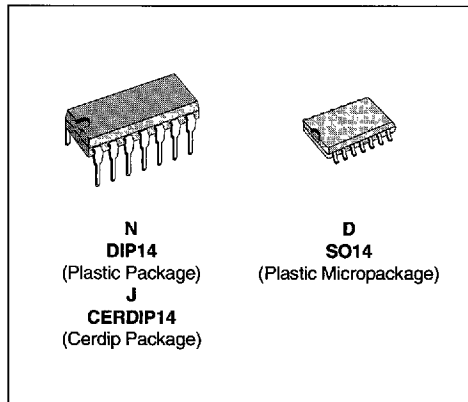

**DESCRIPTION**

The TEB4033, TEF4033 and TEC4033 are high performance quad-operational amplifiers intended for active filter applications. The internal phase compensation allows stable operation as voltage follower in spite of their high gain-bandwidth products. The circuits present very stable electrical characteristics over the entire supply voltage range.

**ORDER CODES**

Part Number	Temperature Range	Package		
		N	J	D
TEB4033	0°C, +70°C	•	•	•
TEF4033	-40°C, +105°C	•	•	•
TEC4033	-55°C, +125°C	•	•	•

**Example** : TEB4033N

4033-01 TBL

**PIN CONNECTIONS (top view)**

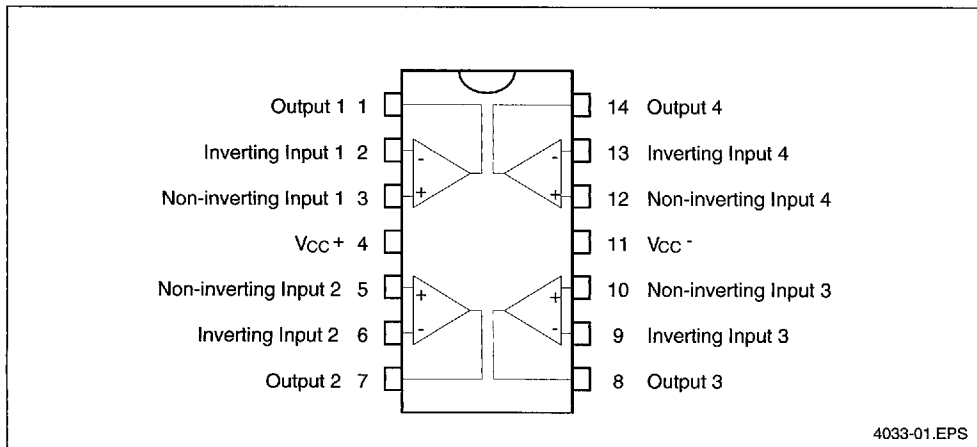

**BLOCK DIAGRAM (1/4 TEB4033)**

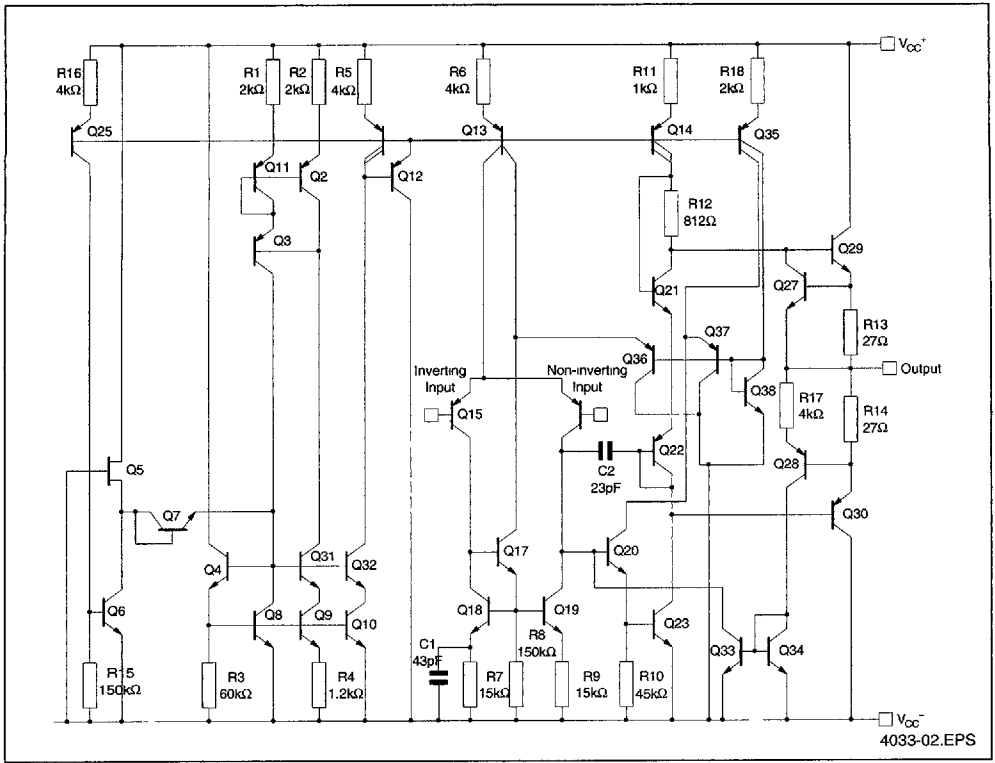

**ABSOLUTE MAXIMUM RATINGS**

Symbol	Parameter	Value	Unit	
V <sub>CC</sub>	Supply Voltage	± 18	V	
V <sub>i</sub>	Input Voltage	± V <sub>CC</sub>	V	
V <sub>id</sub>	Differential Input Voltage	± (V <sub>CC</sub> - 1)	V	
P <sub>tot</sub>	Power Dissipation	D suffix N suffix	400 665	mW
T <sub>oper</sub>	Operating Free-air Temperature Range	TEB4033 TEF4033 TEC4033	0 to +70 -40 to +105 -55 to +125	°C
T <sub>stg</sub>	Storage Temperature Range		-65 to +150	°C

4033-02.TBL

## ELECTRICAL CHARACTERISTICS

V<sub>CC</sub> = ±15V, T<sub>amb</sub> = +25°C (unless otherwise specified)

Symbol	Parameter	TEB 1033 TEF 1033 TEC 1033			Unit
		Min.	Typ.	Max.	
V <sub>io</sub>	Input Offset Voltage (R <sub>S</sub> ≤ 10kΩ) T <sub>amb</sub> = 25°C T <sub>min.</sub> ≤ T <sub>amb</sub> ≤ T <sub>max.</sub>		0.3	1 3	mV
DV <sub>io</sub>	Input Offset Voltage Drift		2		μV/°C
I <sub>io</sub>	Input Offset Current T <sub>amb</sub> = 25°C T <sub>min.</sub> ≤ T <sub>amb</sub> ≤ T <sub>max.</sub>		5	20 40	nA
I <sub>b</sub>	Input Bias Current T <sub>amb</sub> = 25°C T <sub>min.</sub> ≤ T <sub>amb</sub> ≤ T <sub>max.</sub>		50	100 200	nA
A <sub>vd</sub>	Large Signal Voltage Gain (R <sub>L</sub> = 2kΩ, V <sub>O</sub> = ±10V) T <sub>amb</sub> = 25°C T <sub>min.</sub> ≤ T <sub>amb</sub> ≤ T <sub>max.</sub>	80 40	120		V/mV
SVR	Supply Voltage Rejection Ratio (DV <sub>CC</sub> from ±15V to ±4V) T <sub>amb</sub> = 25°C T <sub>min.</sub> ≤ T <sub>amb</sub> ≤ T <sub>max.</sub>	80 70	100		dB
I <sub>CC</sub>	Supply Current, all Amp, no Load T <sub>amb</sub> = 25°C T <sub>min.</sub> ≤ T <sub>amb</sub> ≤ T <sub>max.</sub>		2	3 4	mA
V <sub>icm</sub>	Input Common Mode Voltage Range T <sub>amb</sub> = 25°C	±12			V
CMR	Common Mode Rejection Ratio (R <sub>S</sub> ≤ 10kΩ, V <sub>I</sub> = ±10V) T <sub>amb</sub> = 25°C T <sub>min.</sub> ≤ T <sub>amb</sub> ≤ T <sub>max.</sub>	80 70	100		dB
I <sub>os</sub>	Output Short-circuit Current T <sub>amb</sub> = 25°C T <sub>min.</sub> ≤ T <sub>amb</sub> ≤ T <sub>max.</sub>	10 10	23	40 40	mA
±V <sub>opp</sub>	Output Voltage Swing T <sub>amb</sub> = 25°C T <sub>min.</sub> ≤ T <sub>amb</sub> ≤ T <sub>max.</sub> V <sub>CC</sub> = ±4V, R <sub>L</sub> = 2kΩ, T <sub>amb</sub> = 25°C V <sub>CC</sub> = ±6V, R <sub>L</sub> = 600Ω, T <sub>amb</sub> = 25°C		R <sub>L</sub> = 2kΩ 13 12 2.8 4.6 R <sub>L</sub> = 2kΩ 3		V
SR	Slew-rate (V <sub>I</sub> = ±10V, R <sub>L</sub> = 2 kΩ, C <sub>L</sub> = 100pF, T <sub>amb</sub> = 25°C, unity gain)	0.6	1		V/μs
GBP	Gain Bandwidth Product (f = 100kHz, T <sub>amb</sub> = 25°C, V <sub>in</sub> = 10mV, R <sub>L</sub> = 2kΩ, C <sub>L</sub> = 100pF)	1.5	2		MHz
R <sub>i</sub>	Input Resistance		1		MΩ
THD	Total Harmonic Distortion (f = 1kHz, A <sub>v</sub> = 20dB, R <sub>L</sub> = 2kΩ, C <sub>L</sub> = 100pF, T <sub>amb</sub> = 25°C, V <sub>O</sub> = 2V <sub>pp</sub> )		0.008	0.05	%
e <sub>n</sub>	Equivalent Input Noise Voltage (f = 1kHz) R <sub>S</sub> = 50Ω R <sub>S</sub> = 1kΩ R <sub>S</sub> = 10kΩ		8 10 18	15	$\frac{nV}{\sqrt{Hz}}$
V <sub>OPP</sub>	Large Signal Voltage Swing R <sub>L</sub> = 10kΩ, f = 10kHz	26	28		V
∅ <sub>m</sub>	Phase Margin		45		Degrees
V <sub>O1</sub> /V <sub>O2</sub>	Channel Separation	100	120		dB

4033-03 TBL

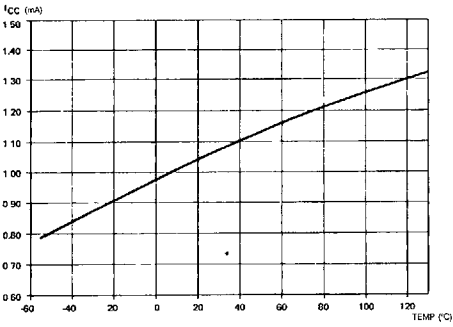

SUPPLY CURRENT VS AMBIENT TEMPERATURE

4033-03 EPS

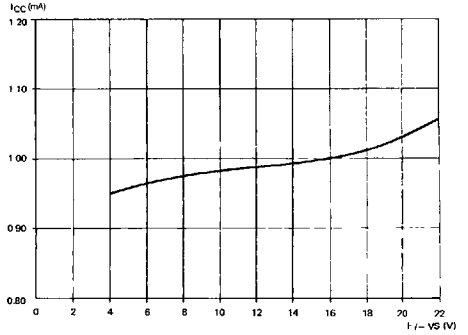

SUPPLY CURRENT VS SUPPLY VOLTAGE

4033-04 EPS

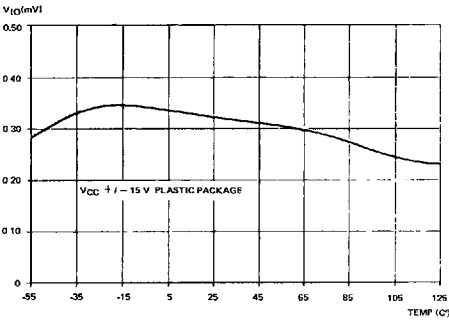

OFFSET VOLTAGE VS. AMBIENT TEMPERATURE

4033-05 EPS

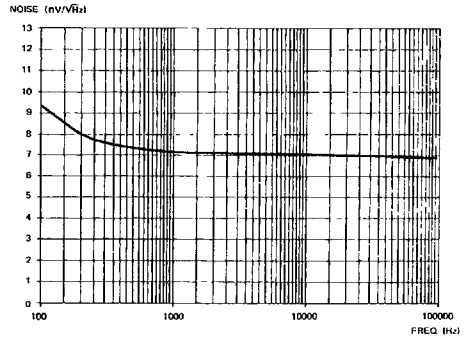

TOTAL INPUT NOISE VS. FREQUENCY

4033-06.EPS

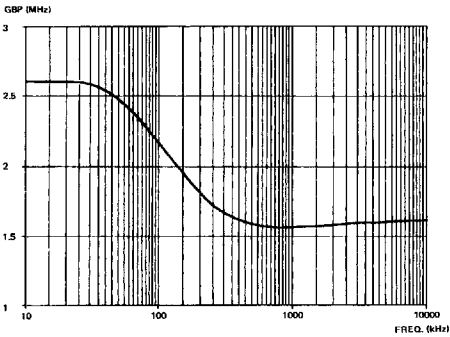

GAIN BANDWIDTH PRODUCT VS. FREQUENCY

4033-07 EPS

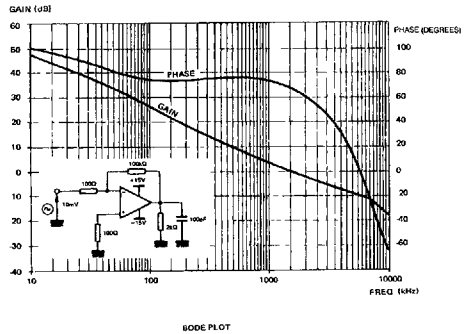

BODE PLOT

4033-08.EPS

## TYPICAL APPLICATION

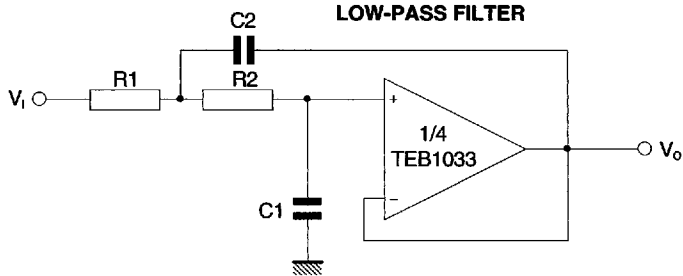

$$\frac{V_o}{V_i} = \frac{1}{1 + 2\xi \frac{S}{\omega_c} + \frac{S^2}{\omega_c^2}}$$

$\omega_c = 2\pi f_c$ , with  $f_c$  = cutt-off frequency  
 $\xi$  = damping factor

4033-09.EPS