

FEATURES

- High Density Hybrid
- 65 dB Voltage Conversion Gain
- 63 dB Attenuation in 1 dB Steps
- Attenuation, Noise Figure and Compression Adapts to Input Signal Levels

HDI



MODEL NO.
DHD08063

IF / AGC HYBRID

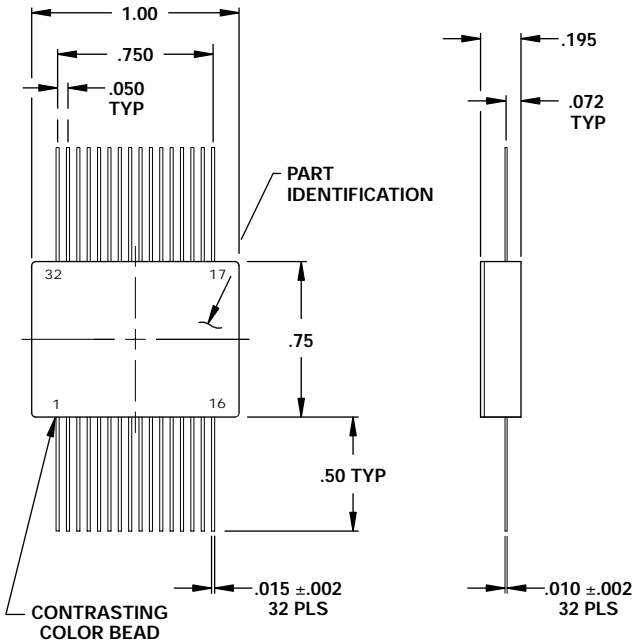

.xx = .02
.xxx = .010

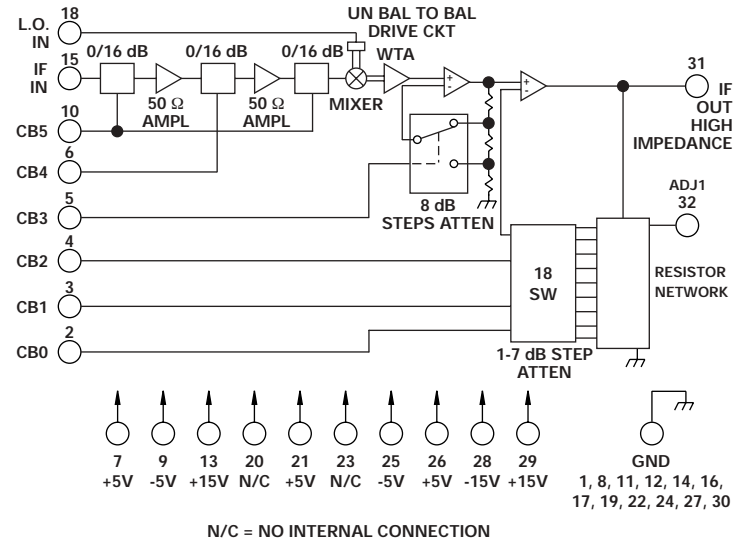

GUARANTEED PERFORMANCE

Parameter	Min	Typ	Max	Units	Conditions
Operating Freq.	IF Input	10	100	MHz	
	LO Input	10	100	MHz	
	IF Output	300	700	KHz	
DC Current		39	50	mA	At +5 VDC Supply
		39	50	mA	At -5 VDC Supply
		130	150	mA	At +15 VDC Supply
		22	30	mA	At -15 VDC Supply
Control Type		TTL			6 Line, See Table Logic "0" = Thru
Control Current	High	±1	±100	µA	VIH = +2.7 V
	Low	±1	±100	µA	VIL = +0.5 V
Conversion Voltage Gain	63	65	66	dB	
Attenuation	LSB		1	dB	1, 2, 4, 8, 16, 32, 64 dB Bits
	Range	0		63	
VSWR		1.2/1	2.0/1		
Impedance		50		OHMS	At Input
		510		OHMS	At Output
Switching Speed		1.6		µSec	
Transition (Rise/Fall) Time		1.5		µSec	
RF Power	At LO Input	-12	-10	-8	At 0 dB Attenuation At 55 dB Attenuation
	At IF Input			-35	
Initial Noise Figure		11.3	15	dB	Single Sideband, at Minimum Attenuation
Operating Temperature	-40	+25	+100	°C	TA