



HIGH-SPEED 3.3V 32/16K x 16 SYNCHRONOUS DUAL-PORT STATIC RAM

IDT70V9279/69S/L

Features:

- ◆ True Dual-Ported memory cells which allow simultaneous access of the same memory location
- ◆ High-speed clock to data access
 - Commercial: 6.5/7.5/9/12/15ns (max.)
 - Industrial: 7.5ns (max.)
- ◆ Low-power operation
 - IDT70V9279/69S
Active: 429mW (typ.)
Standby: 3.3mW (typ.)
 - IDT70V9279/69L
Active: 429mW (typ.)
Standby: 1.32mW (typ.)
- ◆ Flow-through or Pipelined output mode on either port via the FT/PIPE pin
- ◆ Counter enable and reset features
- ◆ Dual chip enables allow for depth expansion without additional logic
- ◆ Full synchronous operation on both ports
 - 4ns setup to clock and 1ns hold on all control, data, and address inputs
 - Data input, address, and control registers
 - Fast 6.5ns clock to data out in the Pipelined output mode
 - Self-timed write allows fast cycle time
 - 10ns cycle time, 100MHz operation in Pipelined output mode
- ◆ Separate upper-byte and lower-byte controls for multiplexed bus and bus matching compatibility
- ◆ LVTTTL-compatible, single 3.3V (±0.3V) power supply
- ◆ Industrial temperature range (–40°C to +85°C) is available for selected speeds
- ◆ Available in a 128-pin Thin Quad Flatpack (TQFP) package

Functional Block Diagram

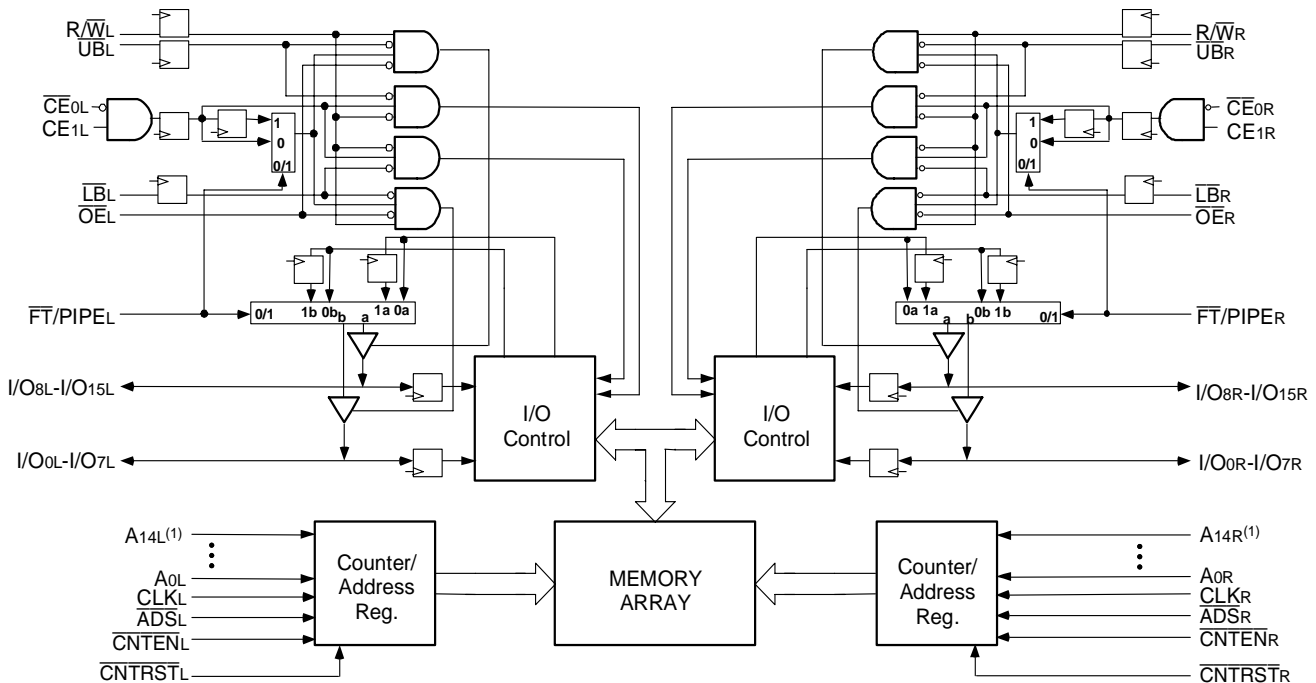

3743 drw 01

NOTE:

1. A14x is a NC for IDT70V9269.

MAY 2004

Description:

The IDT70V9279/69 is a high-speed 32/16K x 16 bit synchronous Dual-Port RAM. The memory array utilizes Dual-Port memory cells to allow simultaneous access of any address from both ports. Registers on control, data, and address inputs provide minimal setup and hold times. The timing latitude provided by this approach allows systems to be designed with very short cycle times.

With an input data register, the IDT70V9279/69 has been optimized for applications having unidirectional or bidirectional data flow in bursts. An automatic power down feature, controlled by \overline{CE}_0 and CE_1 , permits the on-chip circuitry of each port to enter a very low standby power mode. Fabricated using IDT's CMOS high-performance technology, these devices typically operate on only 429mW of power.

Pin Configuration^(2,3,4)

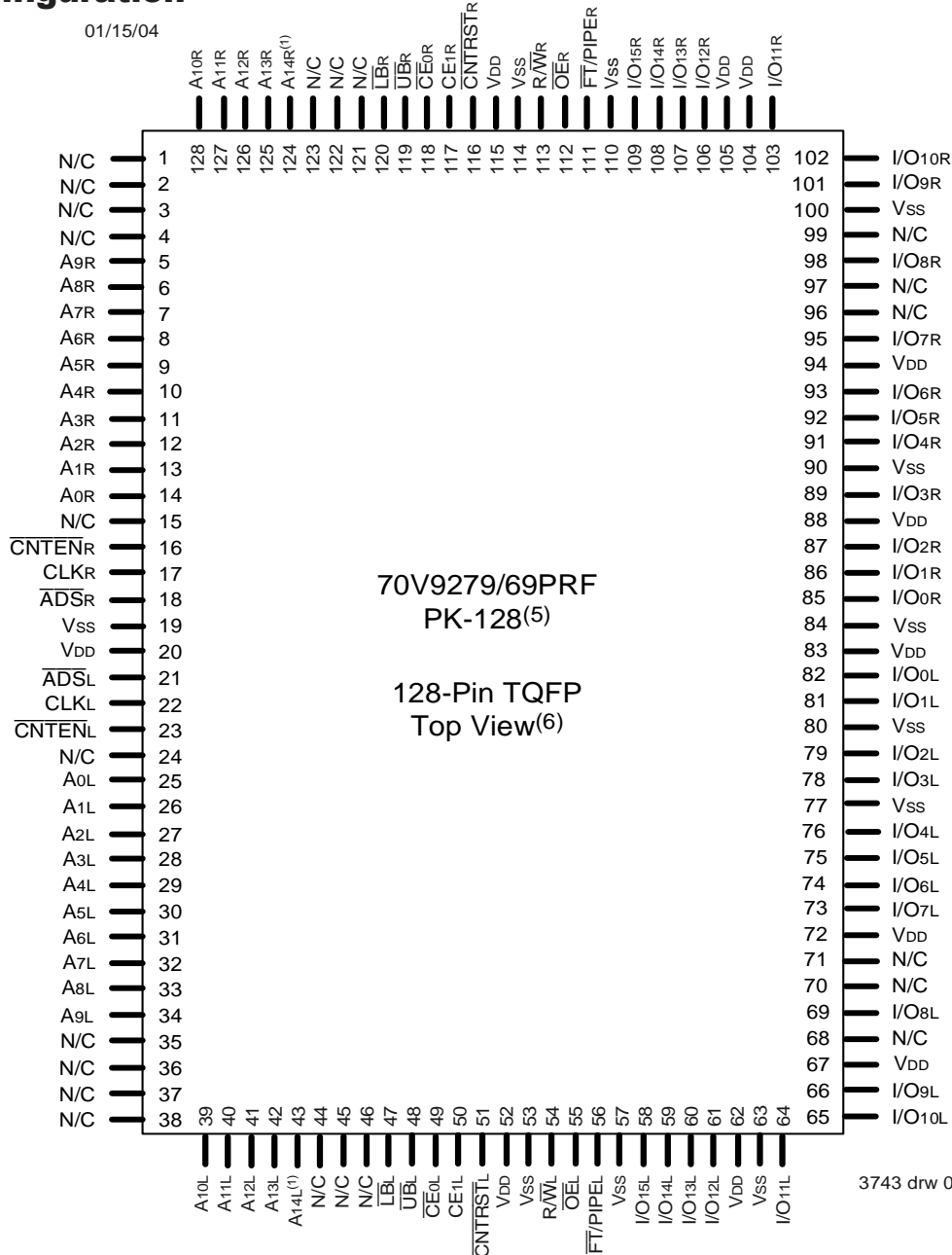

NOTES:

1. A14x is a NC for IDT70V9269.
2. All V_{DD} pins must be connected to power supply.
3. All V_{SS} pins must be connected to ground.
4. Package body is approximately 14mm x 20mm x 1.4mm.
5. This package code is used to reference the package diagram.
6. This text does not indicate orientation of the actual part-marking.

Pin Names

| Left Port | Right Port | Names |
|---------------------------|---------------------------|----------------------------------|
| $\overline{CE}0L, CE1L$ | $\overline{CE}0R, CE1R$ | Chip Enables ⁽³⁾ |
| R/ \overline{W} L | R/ \overline{W} R | Read/Write Enable |
| $\overline{OE}L$ | $\overline{OE}R$ | Output Enable |
| A0L - A14L ⁽¹⁾ | A0R - A14R ⁽¹⁾ | Address |
| I/O0L - I/O15L | I/O0R - I/O15R | Data Input/Output |
| CLKL | CLKR | Clock |
| $\overline{UB}L$ | $\overline{UB}R$ | Upper Byte Select ⁽²⁾ |
| $\overline{LB}L$ | $\overline{LB}R$ | Lower Byte Select ⁽²⁾ |
| $\overline{ADS}L$ | $\overline{ADS}R$ | Address Strobe Enable |
| $\overline{CNTEN}L$ | $\overline{CNTEN}R$ | Counter Enable |
| $\overline{CNTRST}L$ | $\overline{CNTRST}R$ | Counter Reset |
| $\overline{FT}/PIPEL$ | $\overline{FT}/PIPER$ | Flow-Through / Pipeline |
| V _{DD} | | Power (3.3V) |
| V _{SS} | | Ground (0V) |

3743 tbl 01

NOTES:

1. Address A_{14x} is a NC for IDT70V9269.
2. \overline{LB} and \overline{UB} are single buffered regardless of state of $\overline{FT}/PIPE$.
3. $\overline{CE}0$ and $CE1$ are single buffered when $\overline{FT}/PIPE = V_{IL}$, $\overline{CE}0$ and $CE1$ are double buffered when $\overline{FT}/PIPE = V_{IH}$, i.e. the signals take two cycles to deselect.

Truth Table I—Read/Write and Enable Control^(1,2,3)

| \overline{OE} | CLK | $\overline{CE}0$ ⁽⁵⁾ | $CE1$ ⁽⁵⁾ | \overline{UB} ⁽⁴⁾ | \overline{LB} ⁽⁴⁾ | R/ \overline{W} | Upper Byte I/O ₈₋₁₅ | Lower Byte I/O ₀₋₇ | MODE |
|-----------------|-----|---------------------------------|----------------------|--------------------------------|--------------------------------|-------------------|--------------------------------|-------------------------------|--------------------------|
| X | ↑ | H | X | X | X | X | High-Z | High-Z | Deselected—Power Down |
| X | ↑ | X | L | X | X | X | High-Z | High-Z | Deselected—Power Down |
| X | ↑ | L | H | H | H | X | High-Z | High-Z | Both Bytes Deselected |
| X | ↑ | L | H | L | H | L | D _{IN} | High-Z | Write to Upper Byte Only |
| X | ↑ | L | H | H | L | L | High-Z | D _{ATAIN} | Write to Lower Byte Only |
| X | ↑ | L | H | L | L | L | D _{ATAIN} | D _{ATAIN} | Write to Both Bytes |
| L | ↑ | L | H | L | H | H | D _{ATAOUT} | High-Z | Read Upper Byte Only |
| L | ↑ | L | H | H | L | H | High-Z | D _{ATAOUT} | Read Lower Byte Only |
| L | ↑ | L | H | L | L | H | D _{ATAOUT} | D _{ATAOUT} | Read Both Bytes |
| H | ↑ | L | H | L | L | X | High-Z | High-Z | Outputs Disabled |

3743 tbl 02

NOTES:

1. "H" = V_{IH}, "L" = V_{IL}, "X" = Don't Care.
2. \overline{ADS} , \overline{CNTEN} , \overline{CNTRST} = X.
3. \overline{OE} is an asynchronous input signal.
4. \overline{LB} and \overline{UB} are single buffered regardless of state of $\overline{FT}/PIPE$.
5. $\overline{CE}0$ and $CE1$ are single buffered when $\overline{FT}/PIPE = V_{IL}$. $\overline{CE}0$ and $CE1$ are double buffered when $\overline{FT}/PIPE = V_{IH}$, i.e. the signals take two cycles to deselect.

Truth Table II—Address Counter Control^(1,2,3)

| External Address | Previous Internal Address | Internal Address Used | CLK | \overline{ADS} | \overline{CNTEN} | \overline{CNRST} | I/O ⁽³⁾ | MODE |
|------------------|---------------------------|-----------------------|-----|------------------|--------------------|--------------------|------------------------|---|
| An | X | An | ↑ | L ⁽⁴⁾ | X | H | D _{I/O} (n) | External Address Used |
| X | An | An + 1 | ↑ | H | L ⁽⁵⁾ | H | D _{I/O} (n+1) | Counter Enabled—Internal Address generation |
| X | An + 1 | An + 1 | ↑ | H | H | H | D _{I/O} (n+1) | External Address Blocked—Counter disabled (An + 1 reused) |
| X | X | A0 | ↑ | X | X | L ⁽⁴⁾ | D _{I/O} (0) | Counter Reset to Address 0 |

NOTES:

- "H" = V_{IH}, "L" = V_{IL}, "X" = Don't Care.
- $\overline{CE0}$, \overline{LB} , \overline{UB} , and \overline{OE} = V_{IL}; CE₁ and R \overline{W} = V_{IH}.
- Outputs configured in Flow-Through Output mode; if outputs are in Pipelined mode the data out will be delayed by one cycle.
- \overline{ADS} and \overline{CNRST} are independent of all other signals including $\overline{CE0}$, CE₁, \overline{UB} and \overline{LB} .
- The address counter advances if \overline{CNTEN} = V_{IL} on the rising edge of CLK, regardless of all other signals including $\overline{CE0}$, CE₁, \overline{UB} and \overline{LB} .

3743 tbl 03

Recommended Operating Temperature and Supply Voltage^(1,2)

| Grade | Ambient Temperature | GND | V _{DD} |
|------------|---------------------|-----|-----------------|
| Commercial | 0°C to +70°C | 0V | 3.3V ± 0.3V |
| Industrial | -40°C to +85°C | 0V | 3.3V ± 0.3V |

NOTES:

3743 tbl 04

- Industrial temperature: for specific speeds, packages and powers contact your sales office.
- This is the parameter T_A. This is the "instant on" case temperature.

Recommended DC Operating Conditions

| Symbol | Parameter | Min. | Typ. | Max. | Unit |
|-----------------|--------------------|---------------------|------|--------------------------------------|------|
| V _{DD} | Supply Voltage | 3.0 | 3.3 | 3.6 | V |
| V _{SS} | Ground | 0 | 0 | 0 | V |
| V _{IH} | Input High Voltage | 2.2 | — | V _{DD} +0.3V ⁽²⁾ | V |
| V _{IL} | Input Low Voltage | -0.3 ⁽¹⁾ | — | 0.8 | V |

NOTES:

3743 tbl 05

- V_{IL} ≥ -1.5V for pulse width less than 10 ns.
- V_{TERM} must not exceed V_{DD} + 0.3V.

Absolute Maximum Ratings⁽¹⁾

| Symbol | Rating | Commercial & Industrial | Unit |
|----------------------------------|--------------------------------------|-------------------------|------|
| V _{TERM} ⁽²⁾ | Terminal Voltage with Respect to GND | -0.5 to +4.6 | V |
| T _{BIAS} ⁽³⁾ | Temperature Under Bias | -55 to +125 | °C |
| T _{STG} | Storage Temperature | -65 to +150 | °C |
| T _{JN} | Junction Temperature | +150 | °C |
| I _{OUT} | DC Output Current | 50 | mA |

3743 tbl 06

NOTES:

- Stresses greater than those listed under ABSOLUTE MAXIMUM RATINGS may cause permanent damage to the device. This is a stress rating only and functional operation of the device at these or any other conditions above those indicated in the operational sections of this specification is not implied. Exposure to absolute maximum rating conditions for extended periods may affect reliability.
- V_{TERM} must not exceed V_{DD} + 0.3V for more than 25% of the cycle time or 10ns maximum, and is limited to ≤ 20mA for the period of V_{TERM} ≥ V_{DD} + 0.3V.
- Ambient Temperature Under DC Bias. No AC Conditions. Chip Deselected.

Capacitance⁽¹⁾**(T_A = +25°C, f = 1.0MHz)**

| Symbol | Parameter | Conditions ⁽²⁾ | Max. | Unit |
|---------------------------------|--------------------|---------------------------|------|------|
| C _{IN} | Input Capacitance | V _{IN} = 3dV | 9 | pF |
| C _{OUT} ⁽³⁾ | Output Capacitance | V _{OUT} = 3dV | 10 | pF |

3743 tbl 07

NOTES:

- These parameters are determined by device characterization, but are not production tested.
- 3dV references the interpolated capacitance when the input and output switch from 0V to 3V or from 3V to 0V.
- C_{OUT} also references C_{I/O}.

DC Electrical Characteristics Over the Operating Temperature and Supply Voltage Range ($V_{DD} = 3.3V \pm 0.3V$)

| Symbol | Parameter | Test Conditions | 70V9279/69S | | 70V9279/69L | | Unit |
|-----------|--------------------------------------|---|-------------|------|-------------|------|---------|
| | | | Min. | Max. | Min. | Max. | |
| $ I_{L} $ | Input Leakage Current ⁽¹⁾ | $V_{DD} = 3.6V, V_{IN} = 0V$ to V_{DD} | — | 10 | — | 5 | μA |
| $ I_{O} $ | Output Leakage Current | $\overline{CE}0 = V_{IH}$ or $CE1 = V_{IL}, V_{OUT} = 0V$ to V_{DD} | — | 10 | — | 5 | μA |
| V_{OL} | Output Low Voltage | $I_{OL} = +4mA$ | — | 0.4 | — | 0.4 | V |
| V_{OH} | Output High Voltage | $I_{OH} = -4mA$ | 2.4 | — | 2.4 | — | V |

NOTE:

3743 tbl 08

- At $V_{DD} \leq 2.0V$ input leakages are undefined.

DC Electrical Characteristics Over the Operating Temperature Supply Voltage Range^(3,6) ($V_{DD} = 3.3V \pm 0.3V$)

| Symbol | Parameter | Test Condition | Version | 70V9279/69X6 Com'1 Only | | 70V9279/69X7 Com'1 Only | | 70V9279/69X9 Com'1 & Ind | | Unit | |
|--------|---|---|---------|----------------------------|------|----------------------------|------|--------------------------------|------|------|----|
| | | | | Typ. ⁽⁴⁾ | Max. | Typ. ⁽⁴⁾ | Max. | Typ. ⁽⁴⁾ | Max. | | |
| IDD | Dynamic Operating Current (Both Ports Active) | $\overline{CE}L$ and $\overline{CE}R = V_{IL}$, Outputs Disabled, $f = f_{MAX}^{(1)}$ | COM'L | S | 220 | 395 | 200 | 335 | 180 | 260 | mA |
| | | | | L | 220 | 350 | 200 | 290 | 180 | 225 | |
| ISB1 | Standby Current (Both Ports - TTL Level Inputs) | $\overline{CE}L = \overline{CE}R = V_{IH}$ $f = f_{MAX}^{(1)}$ | COM'L | S | 70 | 145 | 60 | 115 | 50 | 75 | mA |
| | | | | L | 70 | 130 | 60 | 100 | 50 | 65 | |
| ISB2 | Standby Current (One Port - TTL Level Inputs) | $\overline{CE}^*A = V_{IL}$ and $\overline{CE}^*B = V_{IH}^{(5)}$ Active Port Outputs Disabled, $f = f_{MAX}^{(1)}$ | COM'L | S | 150 | 280 | 130 | 240 | 110 | 170 | mA |
| | | | | L | 150 | 250 | 130 | 210 | 110 | 150 | |
| ISB3 | Full Standby Current (Both Ports - CMOS Level Inputs) | Both Ports $\overline{CE}L$ and $\overline{CE}R \geq V_{DD} - 0.2V$, $V_{IN} \geq V_{DD} - 0.2V$ or $V_{IN} \leq 0.2V, f = 0^{(2)}$ | COM'L | S | 1.0 | 5 | 1.0 | 5 | 1.0 | 5 | mA |
| | | | | L | 0.4 | 3 | 0.4 | 3 | 0.4 | 3 | |
| ISB4 | Full Standby Current (One Port - CMOS Level Inputs) | $\overline{CE}^*A \leq 0.2V$ and $\overline{CE}^*B \geq V_{DD} - 0.2V^{(5)}$ $V_{IN} \geq V_{DD} - 0.2V$ or $V_{IN} \leq 0.2V$, Active Port, Outputs Disabled, $f = f_{MAX}^{(1)}$ | COM'L | S | 140 | 270 | 120 | 230 | 100 | 160 | mA |
| | | | | L | 140 | 240 | 120 | 200 | 100 | 140 | |
| | | | IND | S | — | — | — | — | 100 | 170 | |
| | | | | L | — | — | — | — | 100 | 150 | |

3743 tbl 09a

NOTES:

- At $f = f_{MAX}$, address and control lines (except Output Enable) are cycling at the maximum frequency clock cycle of $1/t_{CYC}$, using "AC TEST CONDITIONS" at input levels of V_{SS} to $3V$.
- $f = 0$ means no address, clock, or control lines change. Applies only to input at CMOS level standby.
- Port "A" may be either left or right port. Port "B" is the opposite from port "A".
- $V_{DD} = 3.3V, T_A = 25^\circ C$ for Typ, and are not production tested. $I_{DD DC}(f=0) = 90mA$ (Typ).
- $\overline{CE}X = V_{IL}$ means $\overline{CE}0X = V_{IL}$ and $CE1X = V_{IH}$
 $\overline{CE}X = V_{IH}$ means $\overline{CE}0X = V_{IH}$ or $CE1X = V_{IL}$
 $\overline{CE}X \leq 0.2V$ means $\overline{CE}0X \leq 0.2V$ and $CE1X \geq V_{DD} - 0.2V$
 $\overline{CE}X \geq V_{DD} - 0.2V$ means $\overline{CE}0X \geq V_{DD} - 0.2V$ or $CE1X \leq 0.2V$
'X' represents "L" for left port or "R" for right port.
- 'X' in part numbers indicate power rating (S or L).

DC Electrical Characteristics Over the Operating Temperature Supply Voltage Range^(3,6) ($V_{DD} = 3.3V \pm 0.3V$)(Cont'd)

| Symbol | Parameter | Test Condition | Version | 70V9279/69X12 Com'1 Only | | 70V9279/69X15 Com'1 Only | | Unit | |
|--------|---|---|---------|-----------------------------|------|-----------------------------|------|------|----|
| | | | | Typ. ⁽⁴⁾ | Max. | Typ. ⁽⁴⁾ | Max. | | |
| IDD | Dynamic Operating Current (Both Ports Active) | \overline{CE}_L and $\overline{CE}_R = V_{IL}$, Outputs Disabled, $f = f_{MAX}^{(1)}$ | COM'L | S | 150 | 240 | 130 | 220 | mA |
| | | | | L | 150 | 205 | 130 | 185 | |
| | | | IND | S | — | — | — | — | |
| | | | | L | — | — | — | — | |
| ISB1 | Standby Current (Both Ports - TTL Level Inputs) | $\overline{CE}_L = \overline{CE}_R = V_{IH}$ $f = f_{MAX}^{(1)}$ | COM'L | S | 40 | 65 | 30 | 55 | mA |
| | | | | L | 40 | 50 | 30 | 35 | |
| | | | IND | S | — | — | — | — | |
| | | | | L | — | — | — | — | |
| ISB2 | Standby Current (One Port - TTL Level Inputs) | $\overline{CE}^*A^* = V_{IL}$ and $\overline{CE}^*B^* = V_{IH}^{(5)}$ Active Port Outputs Disabled, $f = f_{MAX}^{(1)}$ | COM'L | S | 100 | 160 | 90 | 150 | mA |
| | | | | L | 100 | 140 | 90 | 130 | |
| | | | IND | S | — | — | — | — | |
| | | | | L | — | — | — | — | |
| ISB3 | Full Standby Current (Both Ports - CMOS Level Inputs) | Both Ports \overline{CE}_L and $\overline{CE}_R \geq V_{DD} - 0.2V$, $V_{IN} \geq V_{DD} - 0.2V$ or $V_{IN} \leq 0.2V$, $f = 0^{(2)}$ | COM'L | S | 1.0 | 5 | 1.0 | 5 | mA |
| | | | | L | 0.4 | 3 | 0.4 | 3 | |
| | | | IND | S | — | — | — | — | |
| | | | | L | — | — | — | — | |
| ISB4 | Full Standby Current (One Port - CMOS Level Inputs) | $\overline{CE}^*A^* \leq 0.2V$ and $\overline{CE}^*B^* \geq V_{DD} - 0.2V^{(6)}$ $V_{IN} \geq V_{DD} - 0.2V$ or $V_{IN} \leq 0.2V$, Active Port, Outputs Disabled, $f = f_{MAX}^{(1)}$ | COM'L | S | 90 | 150 | 80 | 140 | mA |
| | | | | L | 90 | 130 | 80 | 120 | |
| | | | IND | S | — | — | — | — | |
| | | | | L | — | — | — | — | |

3743 tbl 09b

NOTES:

- At $f = f_{MAX}$, address and control lines (except Output Enable) are cycling at the maximum frequency clock cycle of $1/t_{cvc}$, using "AC TEST CONDITIONS" at input levels of V_{SS} to $3V$.
- $f = 0$ means no address, clock, or control lines change. Applies only to input at CMOS level standby.
- Port "A" may be either left or right port. Port "B" is the opposite from port "A".
- $V_{DD} = 3.3V$, $T_A = 25^\circ C$ for Typ, and are not production tested. $I_{DD\ dc}(f=0) = 90mA$ (Typ).
- $\overline{CE}_X = V_{IL}$ means $\overline{CE}_{0X} = V_{IL}$ and $CE_{1X} = V_{IH}$
 $\overline{CE}_X = V_{IH}$ means $\overline{CE}_{0X} = V_{IH}$ or $CE_{1X} = V_{IL}$
 $\overline{CE}_X \leq 0.2V$ means $\overline{CE}_{0X} \leq 0.2V$ and $CE_{1X} \geq V_{DD} - 0.2V$
 $\overline{CE}_X \geq V_{DD} - 0.2V$ means $\overline{CE}_{0X} \geq V_{DD} - 0.2V$ or $CE_{1X} \leq 0.2V$
 'X' represents "L" for left port or "R" for right port.
- 'X' in part numbers indicate power rating (S or L).

AC Test Conditions

| | |
|-------------------------------|---------------------|
| Input Pulse Levels | GND to 3.0V |
| Input Rise/Fall Times | 3ns |
| Input Timing Reference Levels | 1.5V |
| Output Reference Levels | 1.5V |
| Output Load | Figures 1, 2, and 3 |

7343 tbl 10

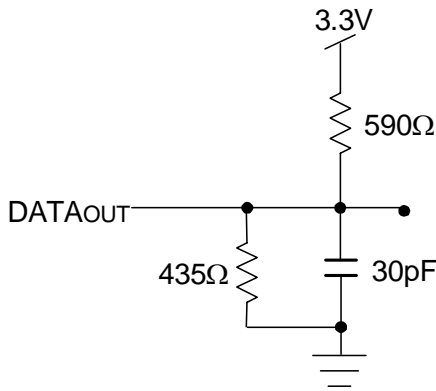

3743 drw 03

Figure 1. AC Output Test load.

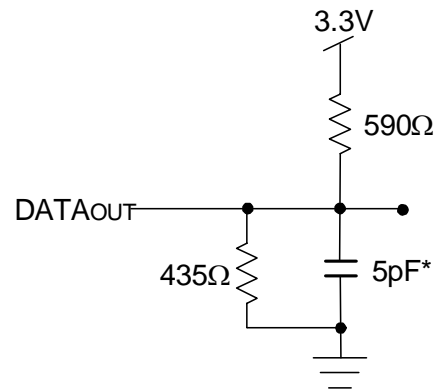

3743 drw 04

Figure 2. Output Test Load
(For tCKLZ, tCKHZ, tOLZ, and tOHZ).
*Including scope and jig.

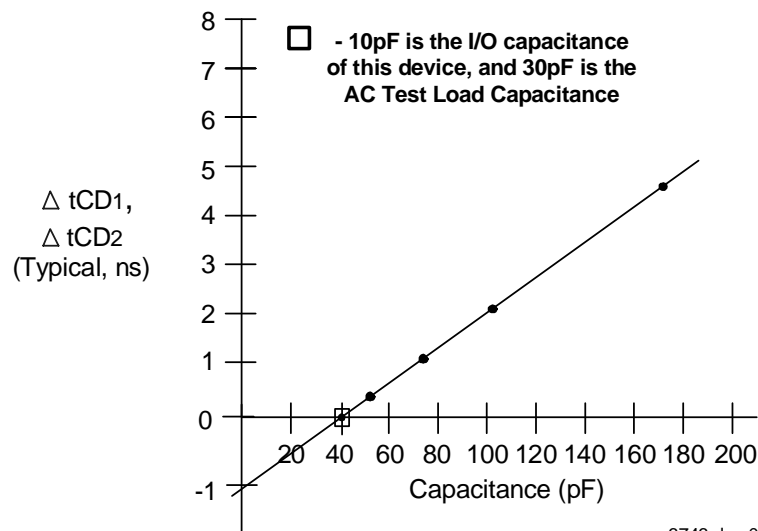

3743 drw 05

Figure 3. Typical Output Derating (Lumped Capacitive Load).

AC Electrical Characteristics Over the Operating Temperature Range (Read and Write Cycle Timing)^(3,4) ($V_{DD} = 3.3V \pm 0.3V$, $T_A = 0^\circ C$ to $+70^\circ C$)

| Symbol | Parameter | 70V9279/69X6 Com'1 Only | | 70V9279/69X7 Com'1 Only | | 70V9279/69X9 Com'1 & Ind | | Unit |
|---------------------------|---|----------------------------|------|----------------------------|------|--------------------------------|------|------|
| | | Min. | Max. | Min. | Max. | Min. | Max. | |
| t _{CYC1} | Clock Cycle Time (Flow-Through) ⁽²⁾ | 19 | — | 22 | — | 25 | — | ns |
| t _{CYC2} | Clock Cycle Time (Pipelined) ⁽²⁾ | 10 | — | 12 | — | 15 | — | ns |
| t _{CH1} | Clock High Time (Flow-Through) ⁽²⁾ | 6.5 | — | 7.5 | — | 12 | — | ns |
| t _{CL1} | Clock Low Time (Flow-Through) ⁽²⁾ | 6.5 | — | 7.5 | — | 12 | — | ns |
| t _{CH2} | Clock High Time (Pipelined) ⁽²⁾ | 4 | — | 5 | — | 6 | — | ns |
| t _{CL2} | Clock Low Time (Pipelined) ⁽²⁾ | 4 | — | 5 | — | 6 | — | ns |
| t _r | Clock Rise Time | — | 3 | — | 3 | — | 3 | ns |
| t _f | Clock Fall Time | — | 3 | — | 3 | — | 3 | ns |
| t _{SA} | Address Setup Time | 3.5 | — | 4 | — | 4 | — | ns |
| t _{HA} | Address Hold Time | 0 | — | 0 | — | 1 | — | ns |
| t _{SC} | Chip Enable Setup Time | 3.5 | — | 4 | — | 4 | — | ns |
| t _{HC} | Chip Enable Hold Time | 0 | — | 0 | — | 1 | — | ns |
| t _{SW} | R/W Setup Time | 3.5 | — | 4 | — | 4 | — | ns |
| t _{HW} | R/W Hold Time | 0 | — | 0 | — | 1 | — | ns |
| t _{SD} | Input Data Setup Time | 3.5 | — | 4 | — | 4 | — | ns |
| t _{HD} | Input Data Hold Time | 0 | — | 0 | — | 1 | — | ns |
| t _{SAD} | \overline{ADS} Setup Time | 3.5 | — | 4 | — | 4 | — | ns |
| t _{HAD} | \overline{ADS} Hold Time | 0 | — | 0 | — | 1 | — | ns |
| t _{SCN} | \overline{CNTEN} Setup Time | 3.5 | — | 4 | — | 4 | — | ns |
| t _{HCN} | \overline{CNTEN} Hold Time | 0 | — | 0 | — | 1 | — | ns |
| t _{SRST} | \overline{CNRST} Setup Time | 3.5 | — | 4 | — | 4 | — | ns |
| t _{HRST} | \overline{CNRST} Hold Time | 0 | — | 0 | — | 1 | — | ns |
| t _{OE} | Output Enable to Data Valid | — | 6.5 | — | 7.5 | — | 9 | ns |
| t _{OLZ} | Output Enable to Output Low-Z ⁽¹⁾ | 2 | — | 2 | — | 2 | — | ns |
| t _{OHZ} | Output Enable to Output High-Z ⁽¹⁾ | 1 | 7 | 1 | 7 | 1 | 7 | ns |
| t _{CD1} | Clock to Data Valid (Flow-Through) ⁽²⁾ | — | 15 | — | 18 | — | 20 | ns |
| t _{CD2} | Clock to Data Valid (Pipelined) ⁽²⁾ | — | 6.5 | — | 7.5 | — | 9 | ns |
| t _{DC} | Data Output Hold After Clock High | 2 | — | 2 | — | 2 | — | ns |
| t _{CKHZ} | Clock High to Output High-Z ⁽¹⁾ | 2 | 9 | 2 | 9 | 2 | 9 | ns |
| t _{CKLZ} | Clock High to Output Low-Z ⁽¹⁾ | 2 | — | 2 | — | 2 | — | ns |
| Port-to-Port Delay | | | | | | | | |
| t _{CWDD} | Write Port Clock High to Read Data Delay | — | 24 | — | 28 | — | 35 | ns |
| t _{CCS} | Clock-to-Clock Setup Time | — | 9 | — | 10 | — | 15 | ns |

NOTES:

3743 tbl 11a

- Transition is measured 0mV from Low or High-impedance voltage with the Output Test Load (Figure 2). This parameter is guaranteed by device characterization, but is not production tested.
- The Pipelined output parameters (t_{CYC2}, t_{CD2}) apply to either or both left and right ports when $\overline{FT}/PIPE = V_{IH}$. Flow-through parameters (t_{CYC1}, t_{CD1}) apply when $\overline{FT}/PIPE = V_{IL}$ for that port.
- All input signals are synchronous with respect to the clock except for the asynchronous Output Enable (\overline{OE}) and $\overline{FT}/PIPE$. $\overline{FT}/PIPE$ should be treated as a DC signal, i.e. steady state during operation.
- 'X' in part number indicates power rating (S or L).

AC Electrical Characteristics Over the Operating Temperature Range (Read and Write Cycle Timing)^(3,4) ($V_{DD} = 3.3V \pm 0.3V$, $T_A = 0^\circ C$ to $+70^\circ C$)(Cont'd)

| Symbol | Parameter | 70V9279/69X12 Com'l Only | | 70V9279/69X15 Com'l Only | | Unit |
|---------------------------|---|-----------------------------|------|-----------------------------|------|------|
| | | Min. | Max. | Min. | Max. | |
| t _{CYC1} | Clock Cycle Time (Flow-Through) ⁽²⁾ | 30 | — | 35 | — | ns |
| t _{CYC2} | Clock Cycle Time (Pipelined) ⁽²⁾ | 20 | — | 25 | — | ns |
| t _{CH1} | Clock High Time (Flow-Through) ⁽²⁾ | 12 | — | 12 | — | ns |
| t _{CL1} | Clock Low Time (Flow-Through) ⁽²⁾ | 12 | — | 12 | — | ns |
| t _{CH2} | Clock High Time (Pipelined) ⁽²⁾ | 8 | — | 10 | — | ns |
| t _{CL2} | Clock Low Time (Pipelined) ⁽²⁾ | 8 | — | 10 | — | ns |
| t _R | Clock Rise Time | — | 3 | — | 3 | ns |
| t _F | Clock Fall Time | — | 3 | — | 3 | ns |
| t _{SA} | Address Setup Time | 4 | — | 4 | — | ns |
| t _{HA} | Address Hold Time | 1 | — | 1 | — | ns |
| t _{SC} | Chip Enable Setup Time | 4 | — | 4 | — | ns |
| t _{HC} | Chip Enable Hold Time | 1 | — | 1 | — | ns |
| t _{SW} | R/W Setup Time | 4 | — | 4 | — | ns |
| t _{HW} | R/W Hold Time | 1 | — | 1 | — | ns |
| t _{SD} | Input Data Setup Time | 4 | — | 4 | — | ns |
| t _{HD} | Input Data Hold Time | 1 | — | 1 | — | ns |
| t _{SAD} | \overline{ADS} Setup Time | 4 | — | 4 | — | ns |
| t _{HAD} | \overline{ADS} Hold Time | 1 | — | 1 | — | ns |
| t _{SCN} | \overline{CNTEN} Setup Time | 4 | — | 4 | — | ns |
| t _{HCN} | \overline{CNTEN} Hold Time | 1 | — | 1 | — | ns |
| t _{SRST} | \overline{CNRST} Setup Time | 4 | — | 4 | — | ns |
| t _{HRST} | \overline{CNRST} Hold Time | 1 | — | 1 | — | ns |
| t _{OE} | Output Enable to Data Valid | — | 12 | — | 15 | ns |
| t _{OLZ} | Output Enable to Output Low-Z ⁽¹⁾ | 2 | — | 2 | — | ns |
| t _{OHZ} | Output Enable to Output High-Z ⁽¹⁾ | 1 | 7 | 1 | 7 | ns |
| t _{CD1} | Clock to Data Valid (Flow-Through) ⁽²⁾ | — | 25 | — | 30 | ns |
| t _{CD2} | Clock to Data Valid (Pipelined) ⁽²⁾ | — | 12 | — | 15 | ns |
| t _{DC} | Data Output Hold After Clock High | 2 | — | 2 | — | ns |
| t _{CKHZ} | Clock High to Output High-Z ⁽¹⁾ | 2 | 9 | 2 | 9 | ns |
| t _{CKLZ} | Clock High to Output Low-Z ⁽¹⁾ | 2 | — | 2 | — | ns |
| Port-to-Port Delay | | | | | | |
| t _{CWDD} | Write Port Clock High to Read Data Delay | — | 40 | — | 50 | ns |
| t _{CCS} | Clock-to-Clock Setup Time | — | 15 | — | 20 | ns |

3743 tbl 11b

NOTES:

1. Transition is measured 0mV from Low or High-impedance voltage with the Output Test Load (Figure 2). This parameter is guaranteed by device characterization, but is not production tested.
2. The Pipelined output parameters (t_{CYC2}, t_{CD2}) apply to either or both left and right ports when $\overline{FT}/PIPE = V_{IH}$. Flow-through parameters (t_{CYC1}, t_{CD1}) apply when $\overline{FT}/PIPE = V_{IL}$ for that port.
3. All input signals are synchronous with respect to the clock except for the asynchronous Output Enable (\overline{OE}) and $\overline{FT}/PIPE$. $\overline{FT}/PIPE$ should be treated as a DC signal, i.e. steady state during operation.
4. 'X' in part number indicates power rating (S or L).

Timing Waveform of Read Cycle for Flow-through Output ($\overline{FT}/\text{PIPE}^{\text{"x"}} = \text{VIL}$)(3,7)

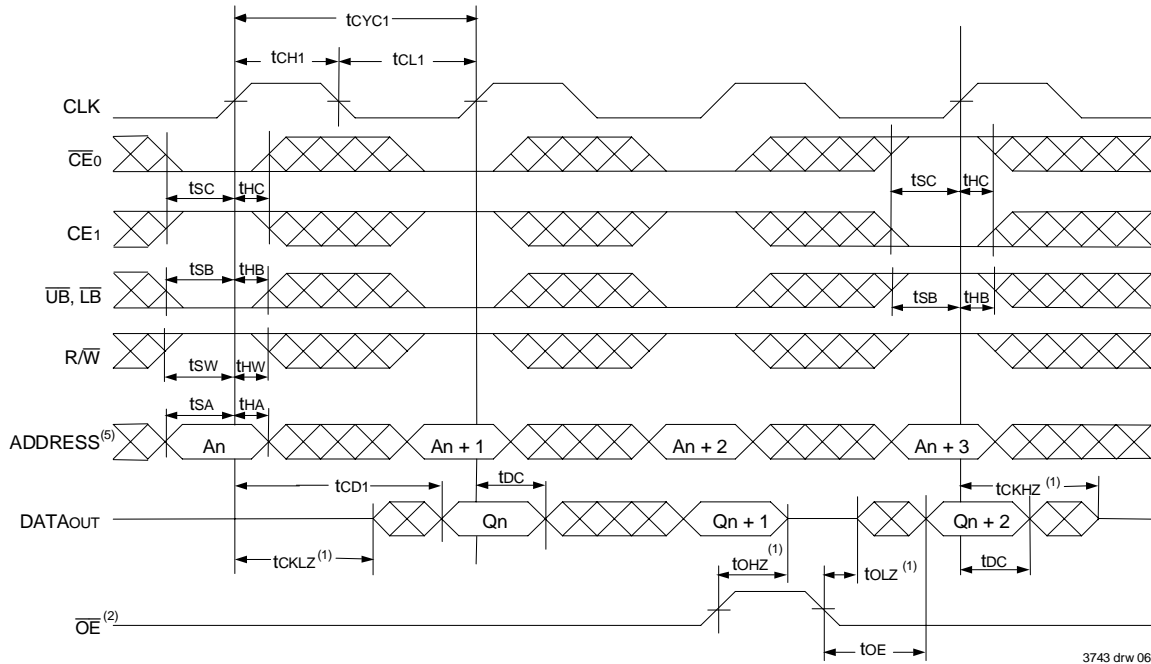

3743 drw 06

Timing Waveform of Read Cycle for Pipelined Output ($\overline{FT}/\text{PIPE}^{\text{"x"}} = \text{VIH}$)(3,7)

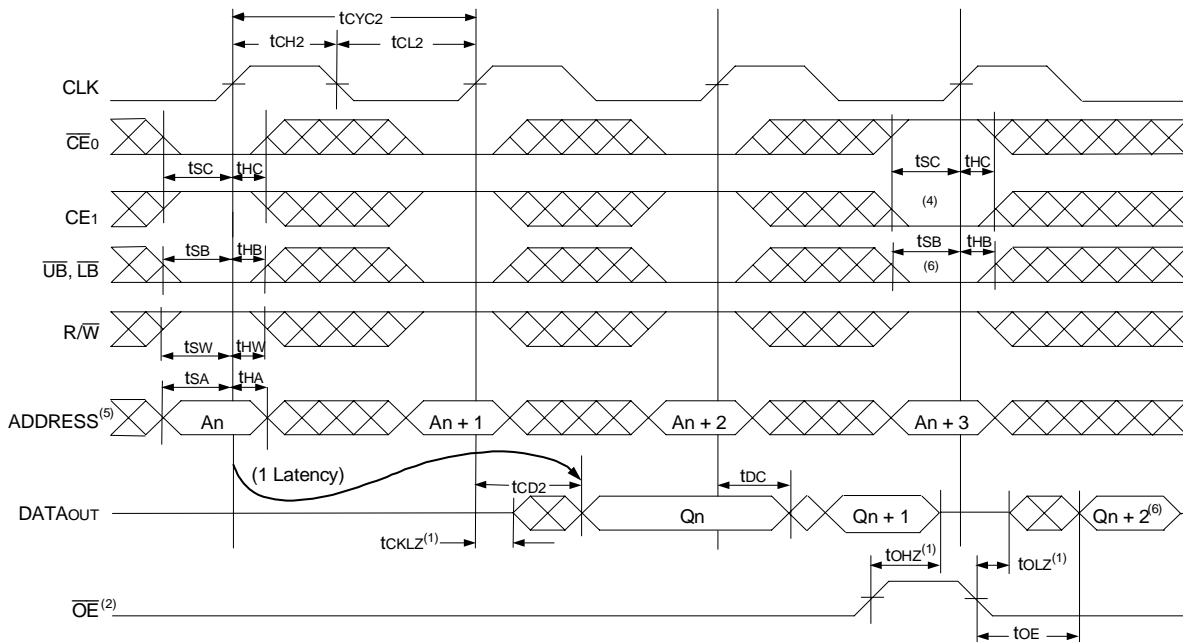

3743 drw 07

NOTES:

1. Transition is measured 0mV from Low or High-impedance voltage with the Output Test Load (Figure 2).
2. \overline{OE} is asynchronously controlled; all other inputs are synchronous to the rising clock edge.
3. $\overline{ADS} = \text{VIL}$, $\overline{\text{CNTEN}}$ and $\overline{\text{CNRST}} = \text{VIH}$.
4. The output is disabled (High-Impedance state) by $\overline{CE0} = \text{VIH}$ or $\text{CE1} = \text{VIL}$ following the next rising edge of the clock. Refer to Truth Table 1.
5. Addresses do not have to be accessed sequentially since $\overline{ADS} = \text{VIL}$ constantly loads the address on the rising edge of the CLK; numbers are for reference use only.
6. If \overline{UB} or \overline{LB} was HIGH, then the Upper Byte and/or Lower Byte of DATAout for $Q_n + 2$ would be disabled (High-Impedance state).
7. "x" denotes Left or Right port. The diagram is with respect to that port.

Timing Waveform of a Bank Select Pipelined Read^(1,2)

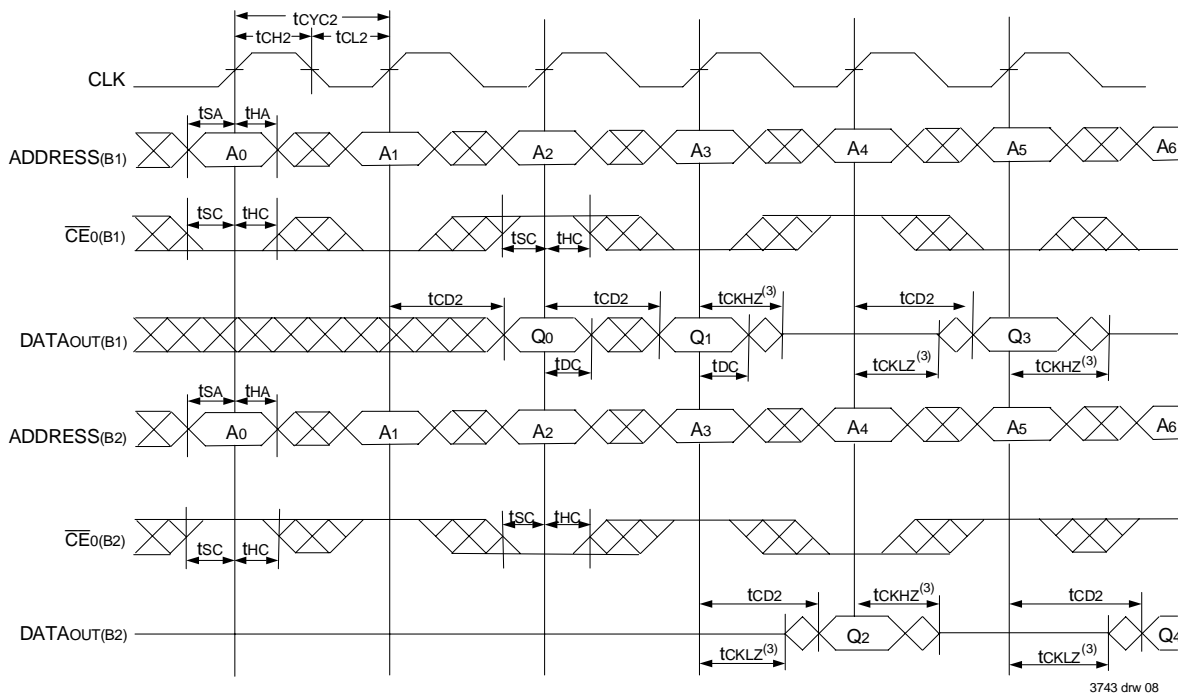

3743 drw 08

Timing Waveform of a Bank Select Flow-Through Read⁽⁶⁾

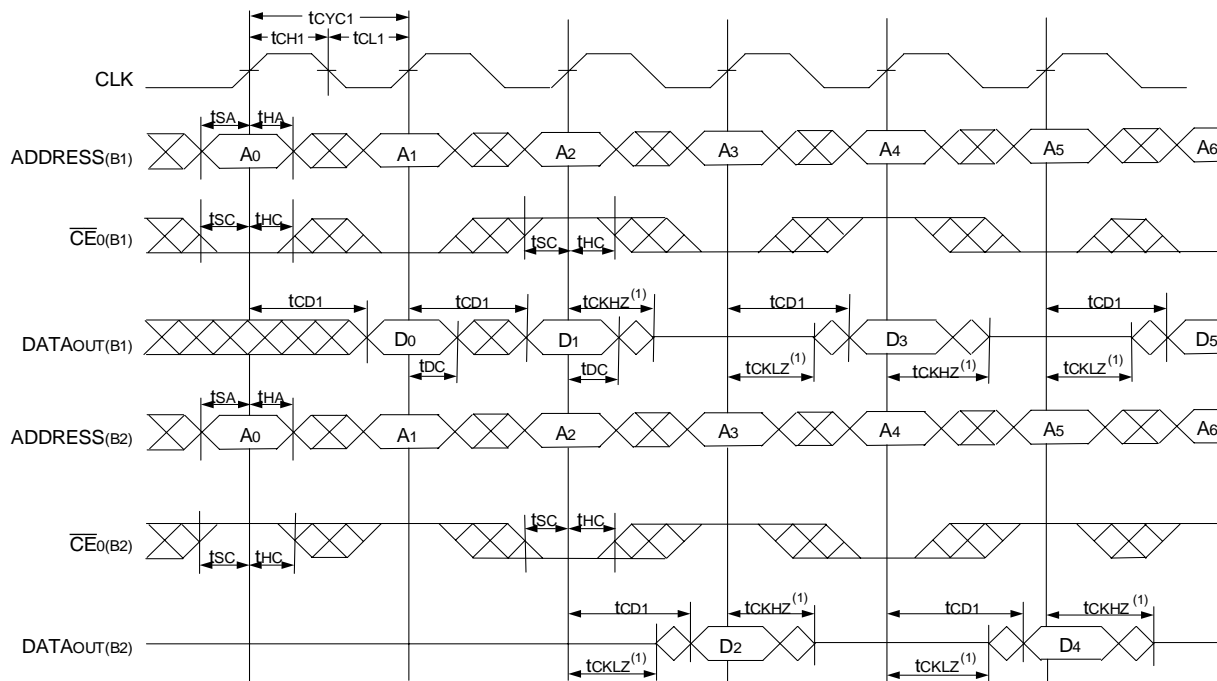

3743 drw 08a

NOTES:

1. B1 Represents Bank #1; B2 Represents Bank #2. Each Bank consists of one IDT70V9279/69 for this waveform, and are setup for depth expansion in this example. ADDRESS_(B1) = ADDRESS_(B2) in this situation.
2. \overline{UB} , \overline{LB} , \overline{OE} , and $\overline{ADS} = V_{IL}$; CE_{1(B1)}, CE_{1(B2)}, R/ \overline{W} , \overline{CNTEN} , and $\overline{CNTRST} = V_{IH}$.
3. Transition is measured 0mV from Low or High-impedance voltage with the Output Test Load (Figure 2).
4. CE₀, \overline{UB} , \overline{LB} , and $\overline{ADS} = V_{IL}$; CE₁, \overline{CNTEN} , and $\overline{CNTRST} = V_{IH}$.
5. $\overline{OE} = V_{IL}$ for the Right Port, which is being read from. $\overline{OE} = V_{IH}$ for the Left Port, which is being written to.
6. If $t_{CCS} \leq$ maximum specified, then data from right port READ is not valid until the maximum specified for t_{CWD} . If $t_{CCS} >$ maximum specified, then data from right port READ is not valid until $t_{CCS} + t_{CD1}$. t_{CWD} does not apply in this case.

Timing Waveform with Port-to-Port Flow-Through Read(1,2,3,5)

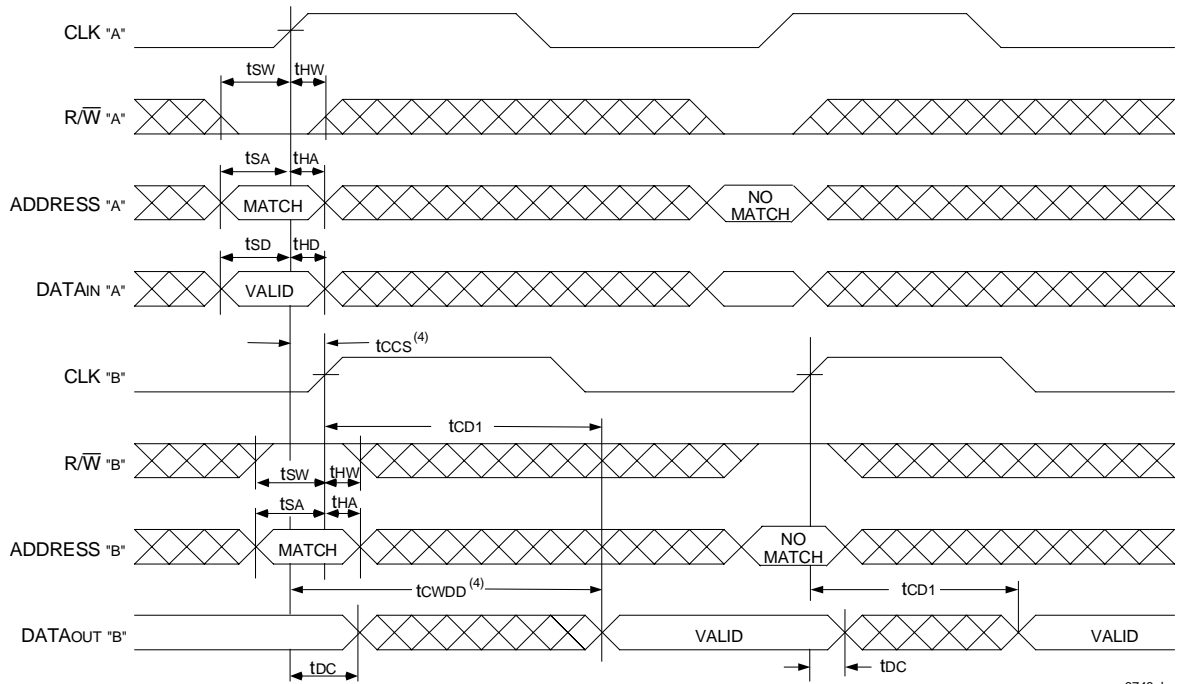

3743 drw 09

NOTES:

1. Transition is measured 0mV from Low or High-impedance voltage with the Output Test Load (Figure 2).
2. \overline{CE}_0 , \overline{UB} , \overline{LB} , and $\overline{ADS} = V_{IL}$; CE_1 , \overline{CNTEN} , and $\overline{CNTRST} = V_{IH}$.
3. $\overline{OE} = V_{IL}$ for the Right Port, which is being read from. $\overline{OE} = V_{IH}$ for the Left Port, which is being written to.
4. If $t_{CCS} \leq$ maximum specified, then data from right port READ is not valid until the maximum specified for t_{CWDD} .
If $t_{CCS} >$ maximum specified, then data from right port READ is not valid until $t_{CCS} + t_{CD1}$. t_{CWDD} does not apply in this case.
5. All timing is the same for both left and right ports. Port "A" may be either left or right port. Port "B" is the opposite of Port "A".

Timing Waveform of Pipelined Read-to-Write-to-Read ($\overline{OE} = V_{IL}$)⁽³⁾

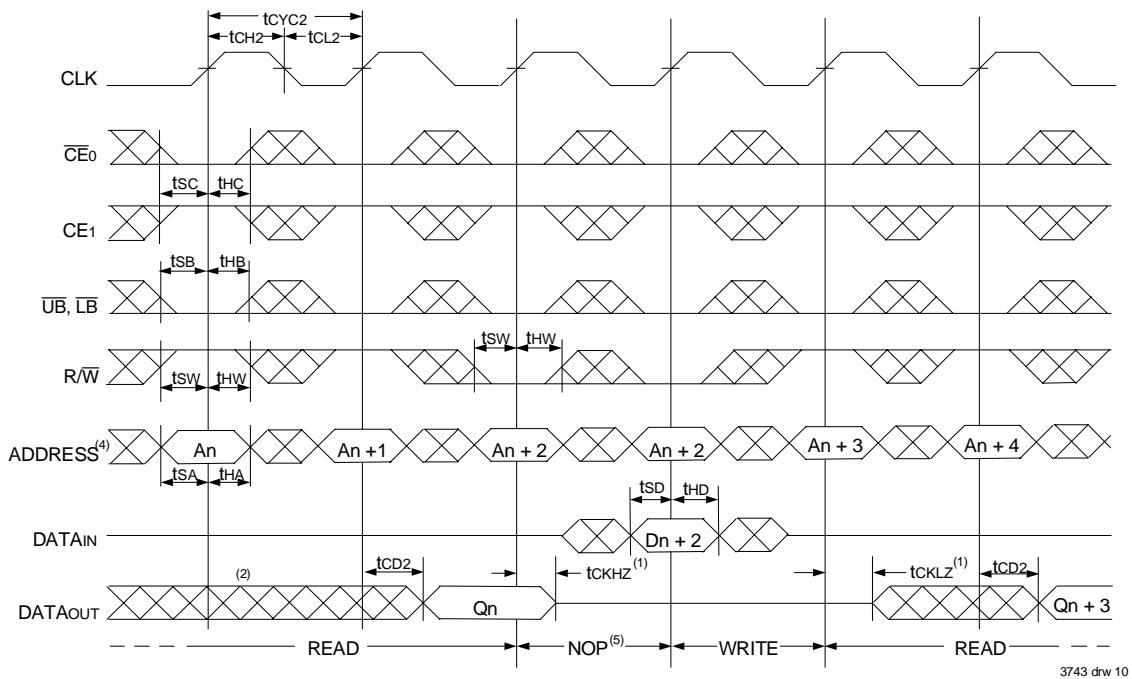

Timing Waveform of Pipelined Read-to-Write-to-Read (\overline{OE} Controlled)⁽³⁾

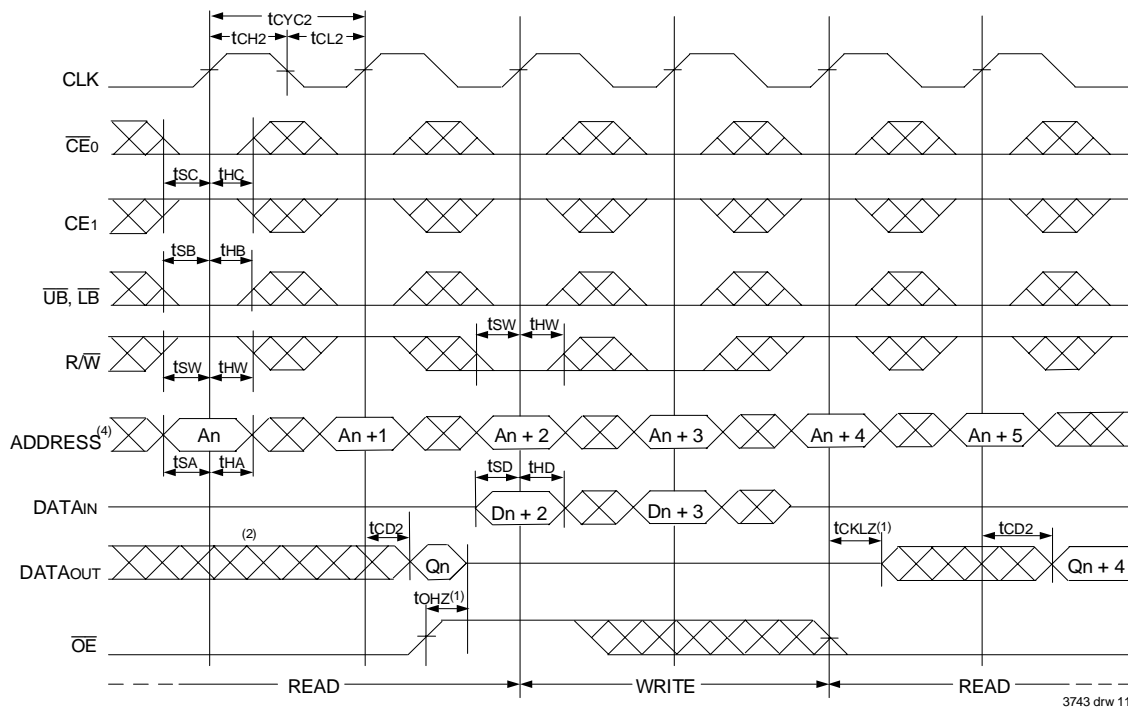

NOTES:

1. Transition is measured 0mV from Low or High-impedance voltage with the Output Test Load (Figure 2).
2. Output state (High, Low, or High-impedance) is determined by the previous cycle control signals.
3. \overline{CE}_0 , \overline{UB} , \overline{LB} , and $\overline{ADS} = V_{IL}$; \overline{CE}_1 , \overline{CNTEN} , and $\overline{CNTRST} = V_{IH}$.
4. Addresses do not have to be accessed sequentially since $\overline{ADS} = V_{IL}$ constantly loads the address on the rising edge of the CLK; numbers are for reference use only.
5. "NOP" is "No Operation." Data in memory at the selected address may be corrupted and should be re-written to guarantee data integrity.

Timing Waveform of Flow-Through Read-to-Write-to-Read ($\overline{OE} = V_{IL}$)⁽³⁾

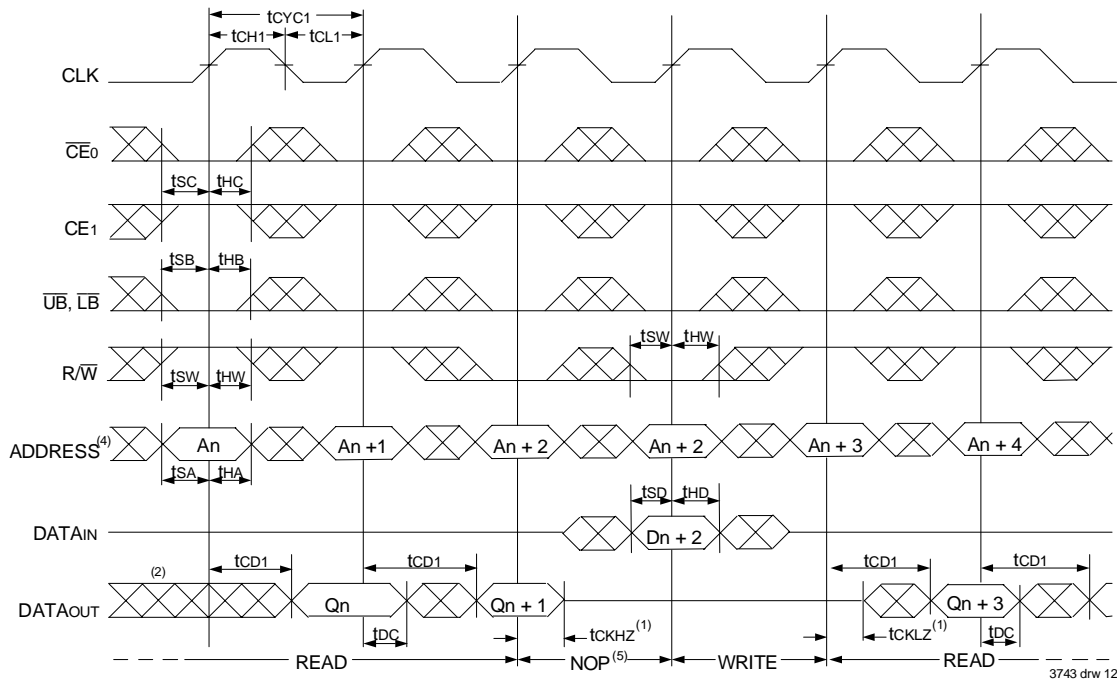

Timing Waveform of Flow-Through Read-to-Write-to-Read (\overline{OE} Controlled)⁽³⁾

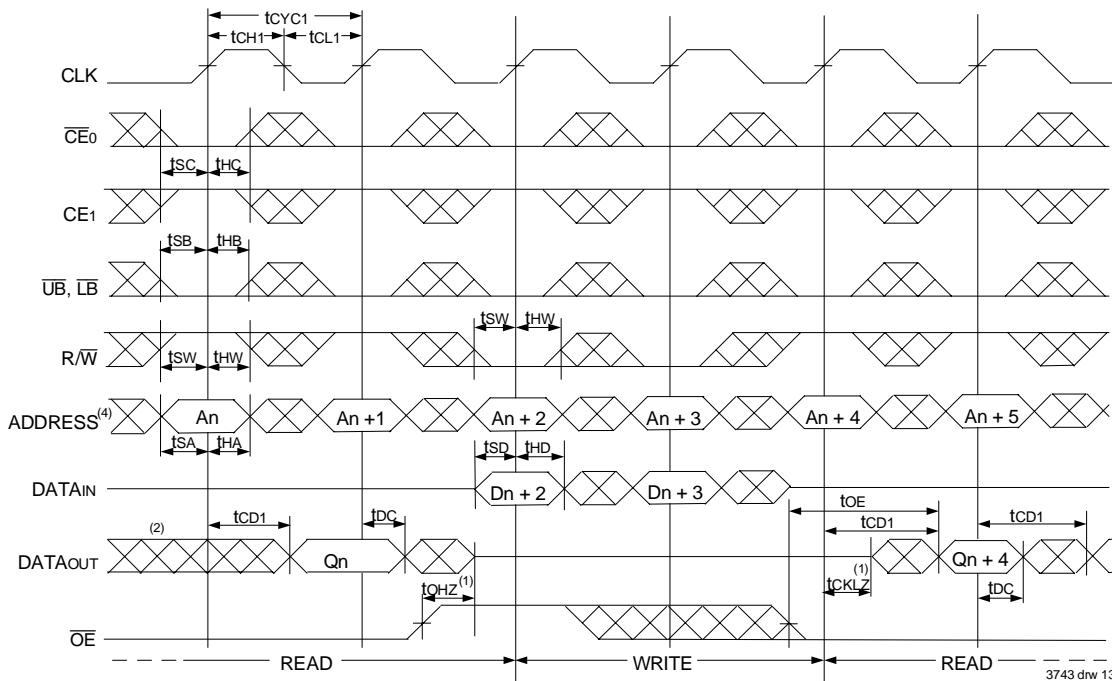

NOTES:

1. Transition is measured 0mV from Low or High-impedance voltage with the Output Test Load (Figure 2).
2. Output state (High, Low, or High-impedance) is determined by the previous cycle control signals.
3. $\overline{CE0}$, \overline{UB} , \overline{LB} , and $\overline{ADS} = V_{IL}$; $\overline{CE1}$, \overline{CNTEN} , and $\overline{CNRST} = V_{IH}$.
4. Addresses do not have to be accessed sequentially since $\overline{ADS} = V_{IL}$ constantly loads the address on the rising edge of the CLK; numbers are for reference use only.
5. "NOP" is "No Operation." Data in memory at the selected address may be corrupted and should be re-written to guarantee data integrity.

Timing Waveform of Pipelined Read with Address Counter Advance⁽¹⁾

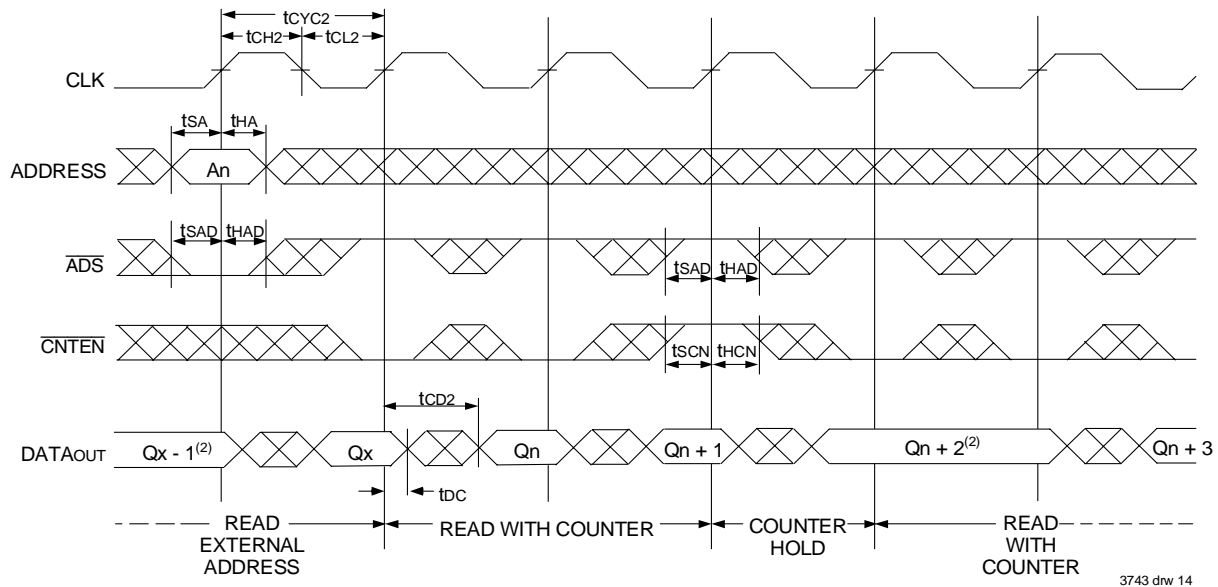

Timing Waveform of Flow-Through Read with Address Counter Advance⁽¹⁾

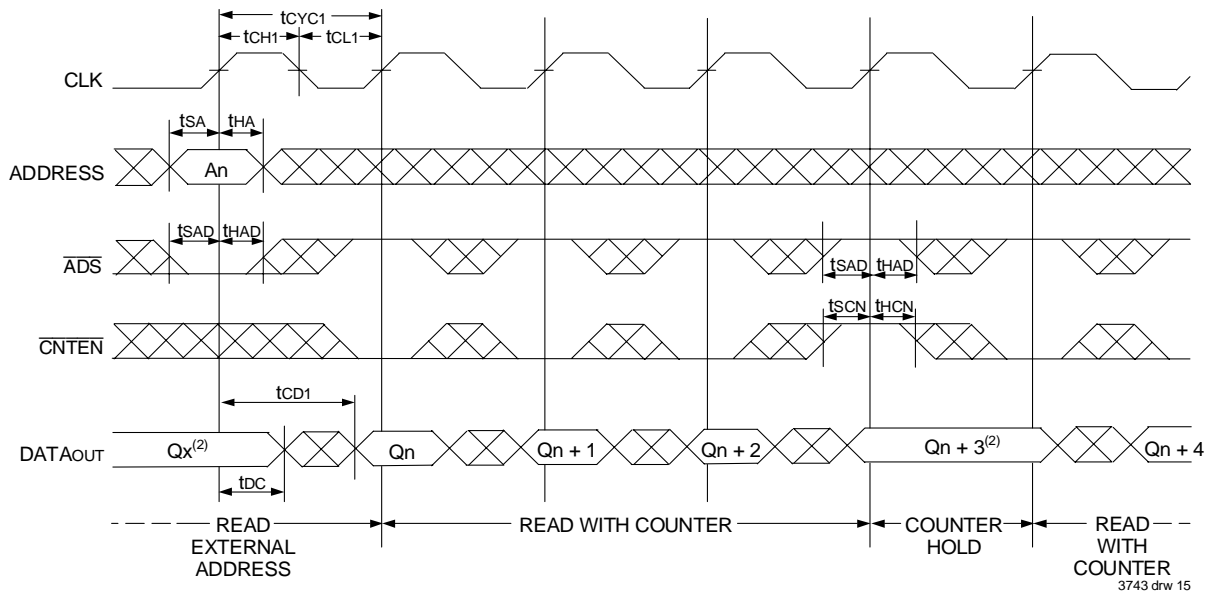

NOTES:

1. \overline{CE}_0 , \overline{OE} , \overline{UB} , and $\overline{LB} = V_{IL}$; CE_1 , $R\overline{W}$, and $\overline{CNTRST} = V_{IH}$.
2. If there is no address change via $ADS = V_{IL}$ (loading a new address) or $\overline{CNTEN} = V_{IL}$ (advancing the address), i.e. $\overline{ADS} = V_{IH}$ and $\overline{CNTEN} = V_{IH}$, then the data output remains constant for subsequent clocks.

Timing Waveform of Write with Address Counter Advance (Flow-Through or Pipelined Outputs)⁽¹⁾

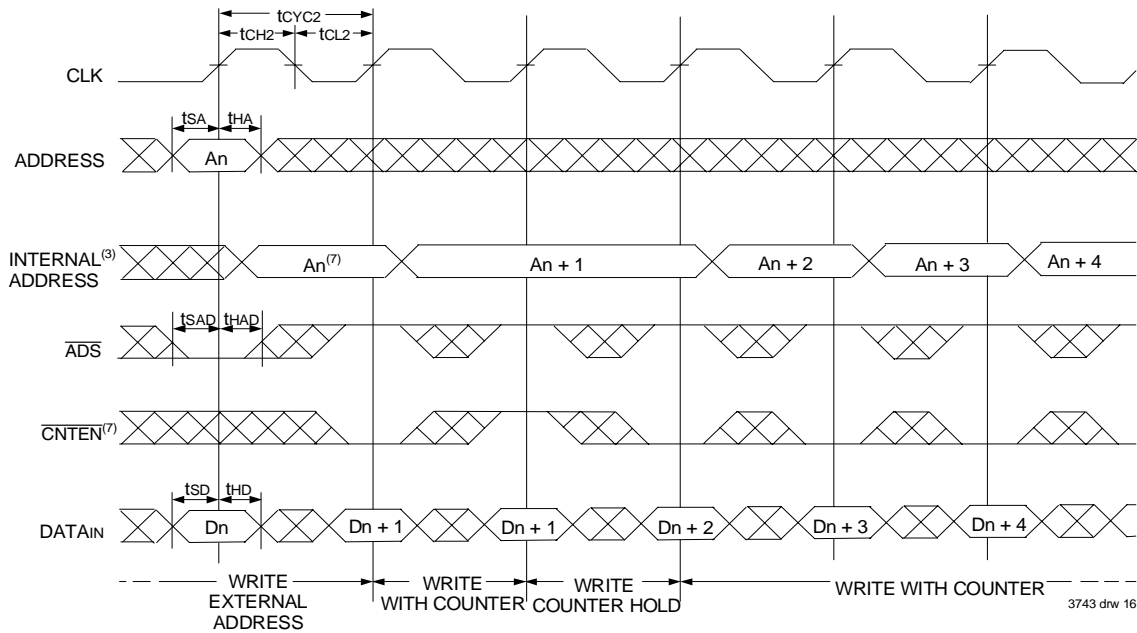

3743 drw 16

Timing Waveform of Counter Reset (Pipelined Outputs)⁽²⁾

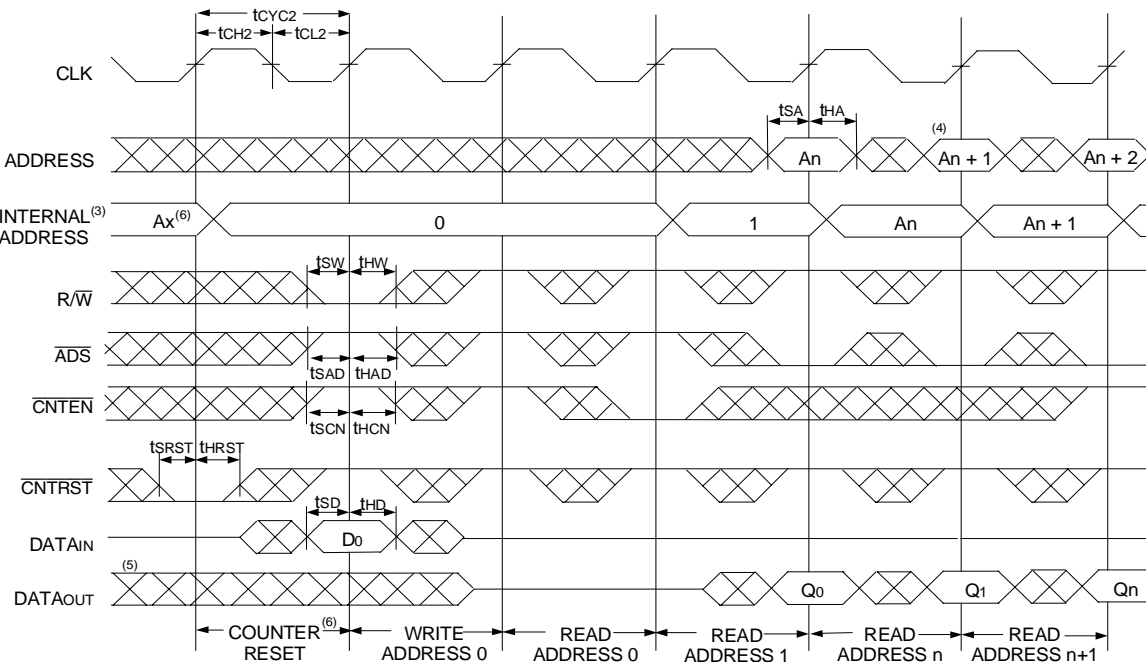

3743 drw 17

NOTES:

1. \overline{CE}_0 , \overline{UB} , \overline{LB} , and R/\overline{W} = V_{IL} ; CE_1 and \overline{CNTRST} = V_{IH} .
2. \overline{CE}_0 , \overline{UB} , \overline{LB} = V_{IL} ; CE_1 = V_{IH} .
3. The "Internal Address" is equal to the "External Address" when $\overline{ADS} = V_{IL}$ and equals the counter output when $\overline{ADS} = V_{IH}$.
4. Addresses do not have to be accessed sequentially since $\overline{ADS} = V_{IL}$ constantly loads the address on the rising edge of the CLK; numbers are for reference use only.
5. Output state (High, Low, or High-impedance) is determined by the previous cycle control signals.
6. No dead cycle exists during counter reset. A READ or WRITE cycle may be coincidental with the counter reset cycle. $ADDR_0$ will be accessed. Extra cycles are shown here simply for clarification.
7. $\overline{CNTEN} = V_{IL}$ advances Internal Address from 'An' to 'An + 1'. The transition shown indicates the time required for the counter to advance. The 'An + 1' Address is written to during this cycle.

Functional Description

The IDT70V9279/69 provides a true synchronous Dual-Port Static RAM interface. Registered inputs provide minimal set-up and hold times on address, data, and all critical control inputs. All internal registers are clocked on the rising edge of the clock signal, however, the self-timed internal write pulse is independent of the LOW to HIGH transition of the clock signal.

An asynchronous output enable is provided to ease asynchronous bus interfacing. Counter enable inputs are also provided to staff the operation of the address counters for fast interleaved memory applications.

A HIGH on $\overline{CE_0}$ or a LOW on CE_1 for one clock cycle will power down the internal circuitry to reduce static power consumption. Multiple chip enables allow easier banking of multiple IDT70V9279/69's for depth expansion configurations. When the Pipelined output mode is enabled, two cycles are required with $\overline{CE_0}$ LOW and CE_1 HIGH to re-activate the outputs.

Depth and Width Expansion

The IDT70V9279/69 features dual chip enables (refer to Truth Table I) in order to facilitate rapid and simple depth expansion with no requirements for external logic. Figure 4 illustrates how to control the various chip enables in order to expand two devices in depth.

The IDT70V9279/69 can also be used in applications requiring expanded width, as indicated in Figure 4. Since the banks are allocated at the discretion of the user, the external controller can be set up to drive the input signals for the various devices as required to allow for 32-bit or wider applications.

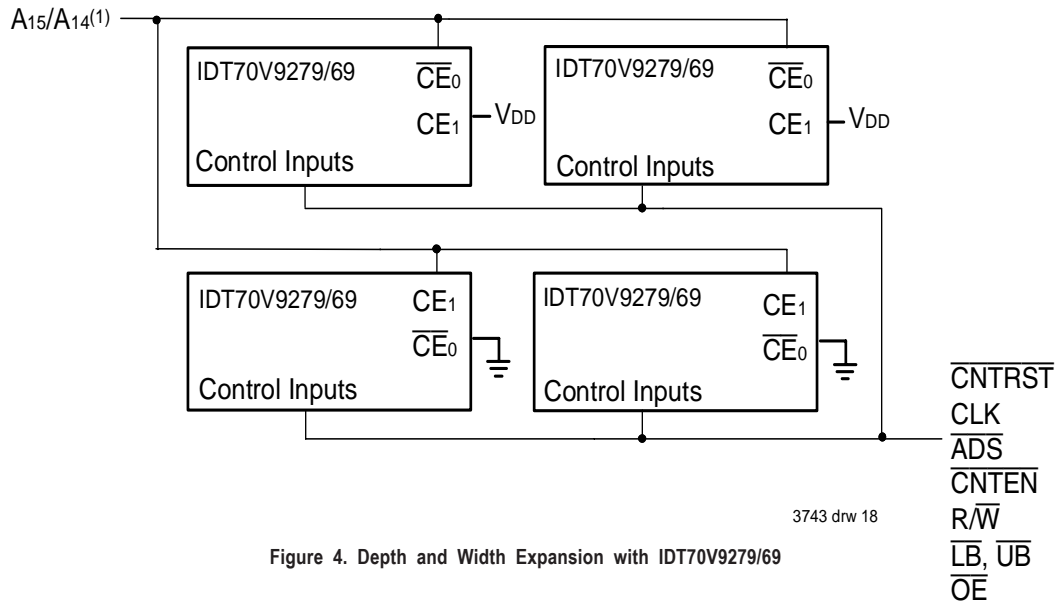
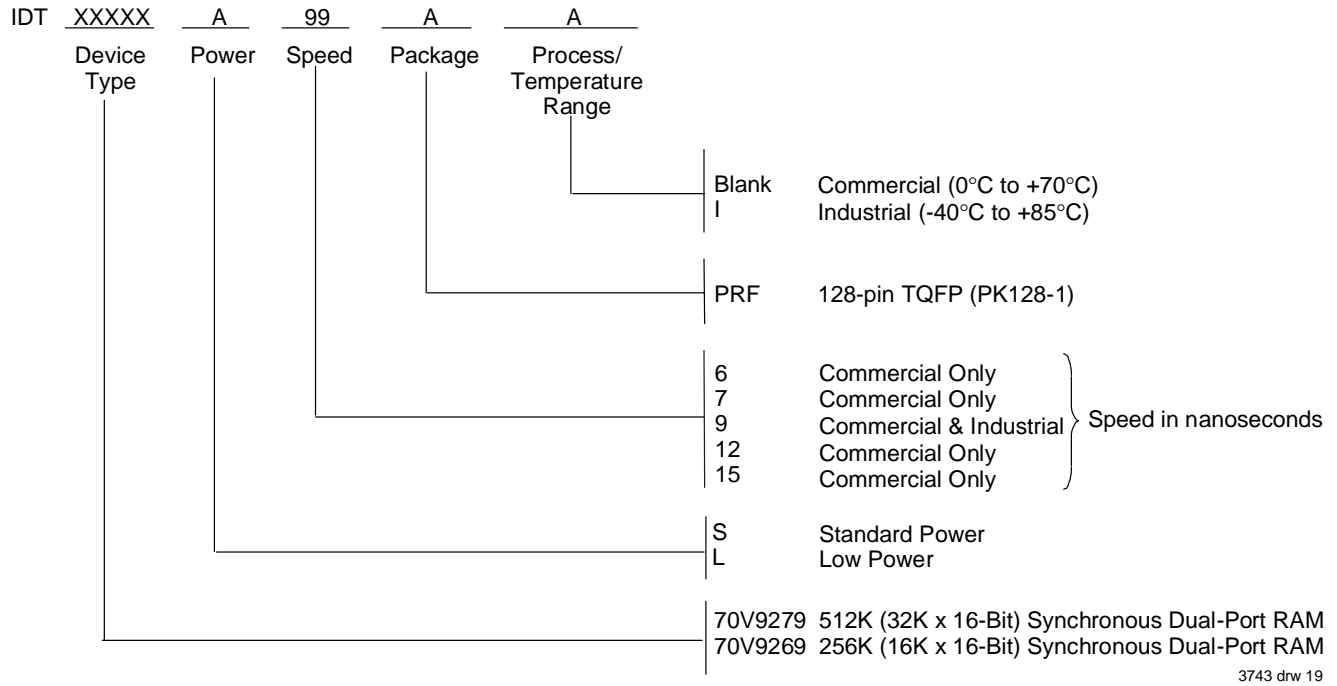

Figure 4. Depth and Width Expansion with IDT70V9279/69

NOTE:

1. A15 is for IDT70V9279. A14 is for IDT70V9269.

Ordering Information



Ordering Information for Flow-through Devices

| Old Flow-through Part | New Combined Part |
|-----------------------|-------------------|
| 70V927S/L25 | 70V9279S/L12 |
| 70V927S/L30 | 70V9279S/L15 |

3743 tbl 12

IDT Clock Solution for IDT70V9279/69 Dual-Port

| IDT Dual-Port Part Number | Dual-Port I/O Specifications | | Clock Specifications | | | | IDT PLL Clock Device | IDT Non-PLL Clock Device |
|---------------------------|------------------------------|--------|----------------------|------------------------------|-------------------|------------------|----------------------|--|
| | Voltage | I/O | Input Capacitance | Input Duty Cycle Requirement | Maximum Frequency | Jitter Tolerance | | |
| 70V9279/69 | 3.3 | LVTTTL | 9pF | 40% | 100 | 150ps | 2305 2308 2309 | 49FCT3805 49FCT3805D/E 74FCT3807 74FCT3807D/E |

3743 tbl 13

Datasheet Document History

- 1/12/99: Initiated datasheet document history
Converted to new format
Cosmetic and typographical corrections
Added additional notes to pin configurations
Page 14 Added Depth & Width Expansion section
- 6/15/99: Page 4 Deleted note 6 for Table II
- 9/29/99: Page 7 Corrected typo in heading
- 11/10/99: Replaced IDT logo
- 3/31/00: Combined Pipelined 70V9279/69 family and Flow-through 70V927 family offerings into one data sheet
Changed $\pm 200\text{mV}$ in waveform notes to 0mV
Added corresponding part chart with ordering information
- 1/17/01: Page 4 Changed information in Truth Table II
Increased storage temperature parameters
Clarified TA parameter
Page 5 DC Electrical parameters—changed wording from "open" to "disabled"
Removed Preliminary status
- 02/25/04: Consolidated multiple devices into one datasheet
Changed naming conventions from VCC to VDD and from GND to VSS
Page 2 Added date revision for pin configuration
Page 3 Added footnotes for $\overline{\text{UB}}$, $\overline{\text{LB}}$, $\overline{\text{CE0}}$ and CE1 buffer conditions when $\overline{\text{FT}}$ or PIPE
Page 4 Added junction temperature to Absolute Maximum Ratings Table
Added Ambient Temperature footnote
Page 5 Added I-temp numbers for 9ns speed to DC Electrical Characteristics Table
Added 6ns speed DC power numbers to the DC Electrical Characteristics Table
Page 7 Added I-temp for 9ns speed to AC Electrical Characteristics Table
Added 6ns speed AC timing numbers to the AC Electrical Characteristics Table
Page 18 Added 6ns speed grade and 9ns I-temp to ordering information
Added IDT Clock Solution Table
- 05/04/04: Page 1 & 19 Updated IDT logo, replaced IDT™ logo with IDT® logo
Page 1 & 18 Added 7ns speed grade to ordering information
Page 5 Added 7ns speed DC power numbers to the DC Electrical Characteristics Table
Page 8 Added 7ns speed AC timing numbers to the AC Electrical Characteristics Table



CORPORATE HEADQUARTERS
2975 Stender Way
Santa Clara, CA 95054

for SALES:
800-345-7015 or 408-727-6116
fax: 408-492-8674
www.idt.com

for Tech Support:
831-754-4613
DualPortHelp@idt.com

The IDT logo is a registered trademark of Integrated Device Technology, Inc.