

GaAs IC 3 Bit Digital Attenuator

4 dB LSB DC–2 GHz



AA230-24
(Previously AD230-24)*

Features

- Attenuation in 4 dB steps to 28 dB with High Accuracy
- Low Cost SOIC-14 Plastic Package
- Low DC Power Consumption

SOIC-14

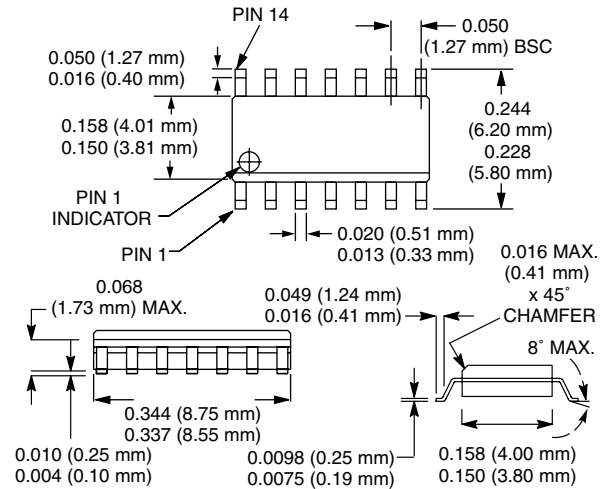

Description

The AD230-24 is an IC FET Digital Attenuator consisting of three monolithic attenuators with LSB of 4 dB and a total attenuation of 28 dB with all attenuators connected. Attenuators are switched with -5 and 0 V.

The AD230-24 is particularly suited where high attenuation accuracy, low insertion loss and low intermodulation products are required. Typical applications include cellular radio, wireless data, wireless local loop and other gain level control circuits.

Electrical Specifications at 25°C (0, -5 V)

Parameter ¹	Frequency ²	Min.	Typ.	Max.	Unit
Insertion Loss ³	DC–0.1 GHz		1.1	1.4	dB
	DC–0.5 GHz		1.2	1.5	dB
	DC–1.0 GHz		1.3	1.7	dB
	DC–2.0 GHz		1.9	2.3	dB
Attenuation Range			28		dB
Attenuation Accuracy ⁴	DC–1.0 GHz	± (0.2 + 3% of Attenuation Setting in dB)			dB
	DC–2.0 GHz	± (0.4 + 5% of Attenuation Setting in dB)			dB
VSWR (I/O)	DC–2.0 GHz		1.3:1	1.5:1	

Operating Characteristics at 25°C (0, -5 V)

Parameter	Condition	Frequency	Min.	Typ.	Max.	Unit
Switching Characteristics ⁵	Rise, Fall (10/90% or 90/10% RF) On, Off (50% CTL to 90/10% RF) Video Feedthru			15		ns
				25		ns
				25		mV
Input Power for 1 dB Compression		0.50–2.0 GHz		+28		dBm
		0.05 GHz		+22		dBm
Intermodulation Intercept Point (IP3)	For Two-tone Input Power +5 dBm	0.50–2.0 GHz		+48		dBm
		0.05 GHz		+38		dBm
Control Voltages	$V_{Low} = 0$ to -0.2 V @ 20 μ A Max. $V_{High} = -5$ V @ 50 μ A Typ. to -8 V @ 200 μ A Max.					

1. All measurements made in a 50 Ω system, unless otherwise specified.
 2. DC = 300 kHz.
 3. Insertion loss changes by 0.003 dB/°C.

4. Attenuation referenced to insertion loss.
 5. Video feedthru measured with 1 ns risetime pulse and 500 MHz bandwidth.

*Due to conflict with another company's product numbering system, Alpha's attenuator products starting with the letters "AD" are being changed to "AA".

Typical Performance Data (0, -5 V)

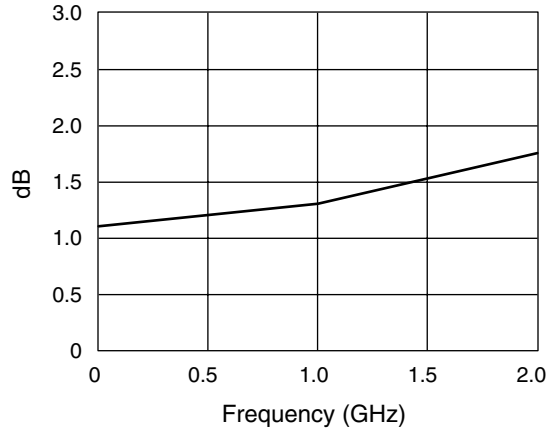

Insertion Loss vs. Frequency

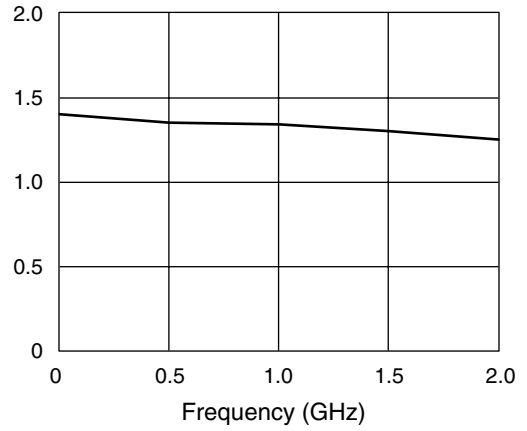

VSWR vs. Frequency (All States)

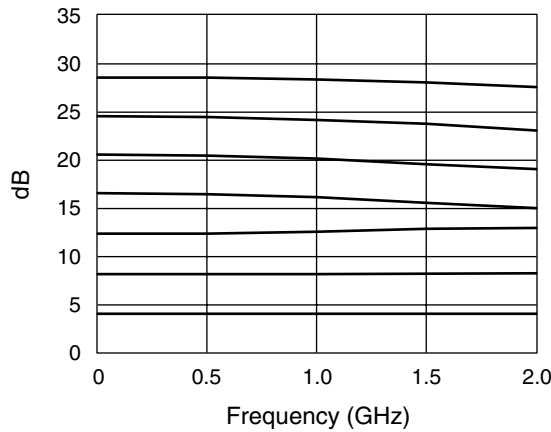

Attenuation vs. Frequency (All States)

Absolute Maximum Ratings

Characteristic	Value
RF Input Power	2 W > 500 MHz 0/-8 V 0.5 W @ 50 MHz 0/-8 V
Control Voltage	+0.2 V, -8 V
Operating Temperature	-40°C to +85°C
Storage Temperature	-65°C to +150°C

Note: Exceeding these parameters may cause irreversible damage.

Pin Out

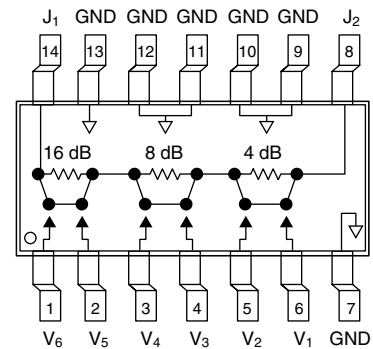

Truth Table

V ₁	V ₂	V ₃	V ₄	V ₅	V ₆	Attenuation J ₁ -J ₂
4 dB	8 dB	16 dB				Reference I.L.
-5	0	-5	0	-5	0	Reference I.L.
0	-5	-5	0	-5	0	4 dB
-5	0	0	-5	-5	0	8 dB
-5	0	-5	0	0	-5	16 dB
0	-5	0	-5	0	-5	28 dB

This datasheet has been download from:

www.datasheetcatalog.com

Datasheets for electronics components.