

Features

- Selectable IF input buffers with characteristic impedance suitable for interface to IF CDMA and FM SAW filter outputs
- AGC amplifiers with 90dB of variable gain, fully compensated for temperature variation
- IQ demodulator with accurately defined output DC level and low DC offsets
- LO operating at twice frequency with high accuracy quadrature generation
- Sophisticated power management control operation
- Overload indicator

Ordering Information

SATURN/KG/QP1S
SATURN/KG/QP1T

Description

The SATURN circuit is designed for use in dual band dual mode mobile phones (CDMA/AMPS). The circuit is designed to be compatible with digital baseband and mixed signal circuit chips from Mitel (Planet Chip-set) and Qualcomm (MSM2 and BBA). A wideband AGC amplifier allows the input of CDMA or AMPS signal paths with a range power management control options.

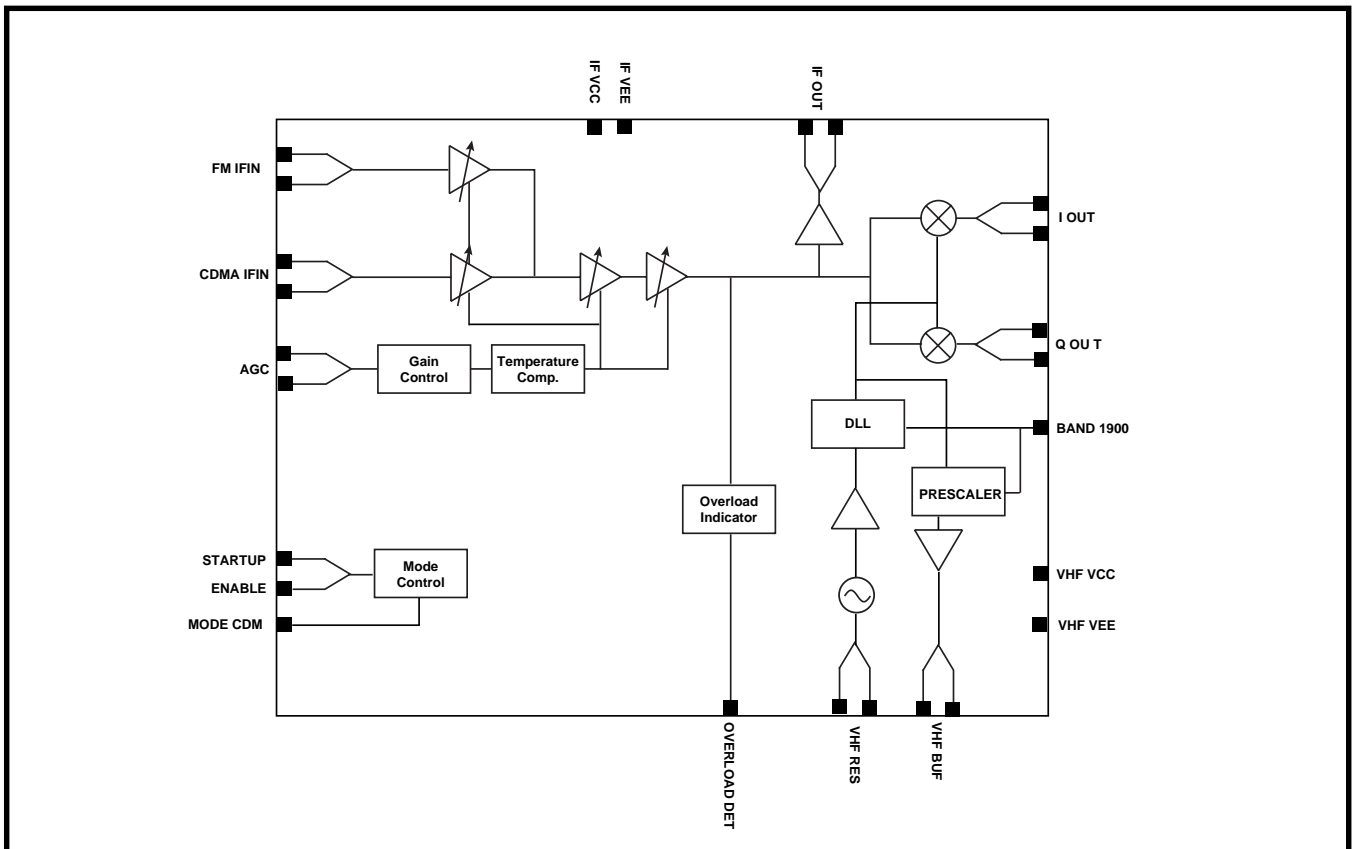

Figure 1 Block diagram

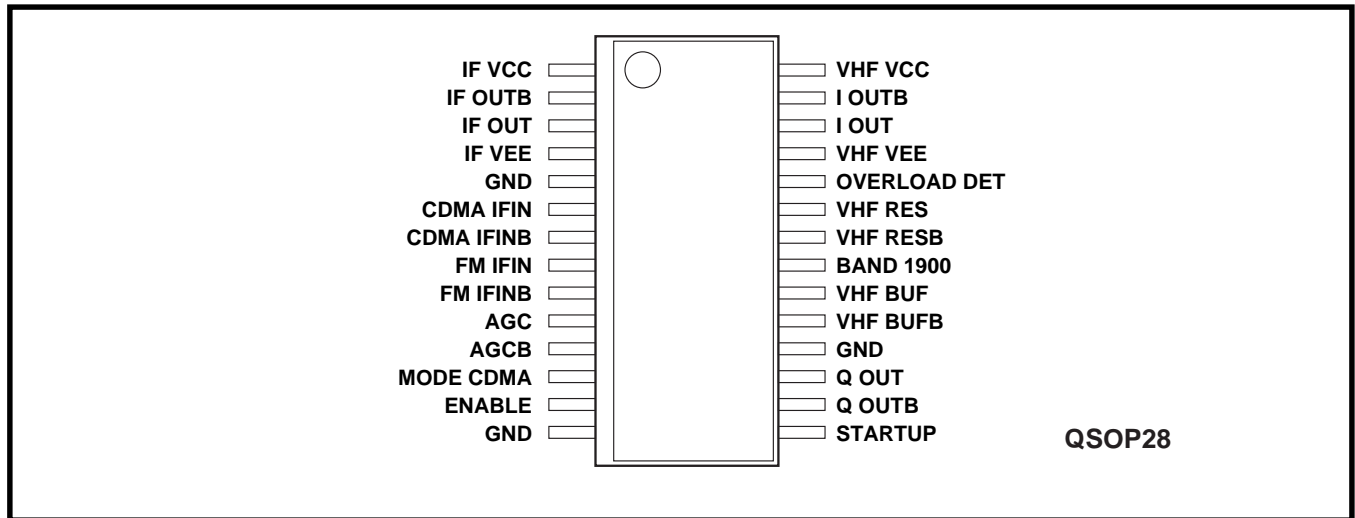

Figure 2 Pin Connections

Pin Description

Pin No	Pin Name	Description
1	IF VCC	Supply for IF inputs and AGC blocks
2	IF OUTB	Post AGC IF output
3	IF OUT	Post AGC IF output
4	IF VEE	Ground for IF inputs and AGC blocks
5	GND	Substrate ground
6	CDMA IFIN	Post SAW IF input (CDMA)
7	CDMA IFINB	Post SAW IN input (CDMA)
8	FM IFIN	Post SAW IF input (FM)
9	FM IFINB	Post SAW IF inputs (FM) (AC ground)
10	AGC	AGC Control for IF section
11	AGCB	AGC control for IF sections (AC ground)
12	MODE CDMA	CDMA/FM mode select
13	ENABLE	Power up AGC sections of device
14	GND	Substrate Ground
15	STARTUP	Power up Oscillator, DLL and Mixer sections of the device
16	QOUTB	Q channel baseband output
17	OUT	Q Channel baseband output
18	GND	Ground
19	VHF BUFB	VHF oscillator buffered output for synthesiser
20	VHF BUF	VHF oscillator buffered output for synthesiser
21	BAND 1900	VHF oscillator tuning band select input
22	VHF RESB	VHF VCO resonator
23	VHF RES	VHF VCO resonator
24	OVERLOAD DET	Overload detector output
25	VHF VEE	Ground for VHF VCO and DLL blocks
26	I OUT	I channel baseband output
27	I OUTB	I channel baseband output
28	VHF VCC	Supply for VHF and DLL blocks

Electrical Characteristics (Mode Control)

Description	ENAVLE	STARTUP	MODE CDMA	BAND 1900	Conditions
Standby Mode	0	0	X	X	All circuits powered down except logic inputs
Start up Mode	0	1	X	1	For high band IF (210.38MHz)
	0	1	X	0	For low band IF (85.38MHz) Turns on VCO circuits, DLL quadrature generation, prescaler and IQ demodulator. All other circuits remain powered down
CDMA mode	1	1	1	1	For high band IF (210.38MHz)
	1	1	1	0	For low band IF (85.38MHz) All circuits operational except for IF output buffer, CDMA input stage selected.
FM Mode	1	1	0	0	All circuits operational except for IF output buffer, FM input stage selected.
Alternative FM mode	1	1	0	1	Note 4
CDMA IF AGC only mode	1	0	1	X	Demodulator and LO generation circuitry powered down. IF output buffer enabled
FM IF AGC	1	0	0	X	Demodulator and LO generation circuitry powered down. IF output buffer enabled.

X = Don't Care

Notes

- STARTUP mode is provided to allow VCO/DLL/prescalers to stabilise before signal path is activated. This is a power-saving feature since the signal path is redundant during this period. If this feature is not required, the ENABLE and STARTUP control pins can be shorted together so that all circuitry is activated at the same time.
- In high band mode (Band 1900 = 1) the VCO operates at twice the IF frequency. For example if IF = 210.38MHz then the oscillator operates at 420.76MHz. A delay locked loop (DLL) circuit then generates the quadrature LO signals. The prescaler output, VHFBUF, is VCO frequency divided by 8 (52.494MHz).
- In low band mode (Band 1900 = 0) the VCO operates at 4 times the IF frequency. for example if IF = 85.38MHz the oscillator operates at 341.52MHz. This is then divided and uses DLL circuit to provide the quadrature LO signals. The prescaler output, VHFBUF, is VCO frequency divided by 8 (42.69MHz).
- This mode can be used for FM. The VCO operates at twice the LO frequency. This mode is not normally used as a large tuning range is required on the VCO. Prescaler output is LO frequency divided by four.

Absolute Limits

Description	Min	Typ	Max	Units	Comments
Supply Voltage			4.0	Volts	
Operation temperature, T _{amb}	-30		+85	°C	Ambient temperature
Storage temperature, T _{stg}	-40		+125	°C	
Junction temperature, T _j	-30		+125	°C	
Power dissipation			350	mW	
Maximum Pin Voltage			V _{cc} +0.6	Volts	All pins except V _{cc} and GND
Minimum Pin Voltage	-0.6			Volts	All pins except V _{cc} and GND
ESD voltage	1.75			kV	Human Body Model

Electrical Characteristics (DC specifications)

T_{amb}= 30°C to +70°C, V_{CC}= +2.7 to +3.6. These characteristics are guaranteed by either production test or design. They apply within the specified ambient temperature and supply voltage unless otherwise stated.

Characteristic	Value			Units	Conditions
	Min	Typ	Max		
General					
Supply Voltage	2.7	3.0	3.6	V	All V _{cc} Pins
Operating temperature	-30	27	85	°C	Ambient See note 1
Current Consumption					
Standby Mode		0.03	0.1	mA	
Startup Mode		8	13	mA	
CDMA Mode		14	23	mA	
FM Mode		14	23	mA	
CDMA AGC only Mode		8	13	mA	
FM AGC only Mode		11	18	mA	
Mode Control Logic					
CMOS input logiv high, V _{IH}	V _{cc} -0.5		V _{cc} +0.1	V	All logic inputs
CMOS input high current, I _{IH}	-10		10	μA	All logic inputs
CMOS input low current, I _{IL}	-10		10	μA	All logic inputs
Switching time between any two Modes		3		ms	
AGC Control	0.1		2.6	V	
AGC Input impedance	100	130	160	kΩ	
DC Common Mode voltages					
I _{OUT} , I _{OUTB} (CDMA Mode)	V _{cc} -0.8	V _{cc} -0.6	V _{cc} -0.4	V	
I _{OUTB} , Q _{OUTB}					
I _{OUT} < Q _{OUT} (FM Mode)	V _{cc} -0.8	V _{cc} -0.6	V _{cc} -0.4	V	
I _{OUTB} , Q _{OUTB}					

Note 1. Specifications are guaranteed over -30 to +70°C, however operation is guaranteed over the extended range of -30 to +85°C with minimal variation in specified parameters.

Electrical Characteristics (AC specifications) Continued

$T_{amb} = 30^{\circ}\text{C}$ to $+70^{\circ}\text{C}$, $V_{CC} = +2.7$ to $+3.6$. These characteristics are guaranteed by either production test or design. They apply within the specified ambient temperature and supply voltage unless otherwise stated.
 Frequency = 210.38MHz

Characteristic	Value			Units	Conditions
	Min	Typ	Max		
CDMA AGC					
Max Voltage Gain to demodulator output	48	50		dB	To demodulator outputs
Min Voltage Gain to demodulator output		-55	-47	dB	To demodulator
Max Voltage Gain to IF buffer output	42	-43		dB	IF AGC only mode
Min voltage Gain to IF buffer output		-51	-49	dB	IF AGC only mode
AGC control Max	2.6			V	Gain = Gain max
AGC control Min			0.1	V	Gain = Gain min
Gain slope		40		dB/V	
Gain slope linearity	6		90	dB/V	Over gain control range
Gain temperature stability	-2		2	dB	
Channel gain variation @ 210.38MHz	-0.1		0.1	dB	Within channel bandwidth
$NF_{Gainmax}$		5.5	6.5	dB	R_s (500 Ω)
Input V1dB _{Gainmin}		110		dB μ V	Minimum gain
	104			dB μ V	Power (500 Ω)
$IIP3_{Gainmin}$	114	120		dB μ V	Minimum gain
Input impedance		500		Ω	With addition of external resistor across IF inputs
IF Frequency	50		250	MHz	
CDMA to Amps isolation	30			dB	

Electrical Characteristics (AC specifications) Continued

$T_{amb} = 30^{\circ}\text{C}$ to $+70^{\circ}\text{C}$, $V_{CC} = +2.7$ to $+3.6$. These characteristics are guaranteed by either production test or design. They apply within the specified ambient temperature and supply voltage unless otherwise stated.
Frequency = 85.38MHz

Characteristic	Value			Units	Conditions
	Min	Typ	Max		
FM AGC					
Max Voltage Gain to demodulator output	52	54		dB	To demodulator outputs
Min Voltage Gain to demodulator output		-49	-47	dB	To demodulator
Max Voltage Gain to OF buffer output	54	59		dB	IF AGC only mode
Min voltage Gain to IF buffer output		-48	-42	dB	IF AGC only mode
AGC control Max	2.6			V	Gain = Gain max
AGC control Min			0.1	V	Gain = Gain min
Gain slope		40		dB/V	
Gain slope linearity	6		80	dB/V	Over gain control range
Gain temperature stability	-2		2	dB	For any gain setting
$NF_{Gainmax}$			6	dB	850Ω source
Input V1dB _{Gainmin}	98	105		dBμV	Minimum gain
IIP3 _{Gainmin}	103	113		dBμV	Minimum gain
Input Impedance		850		Ω	With addition of external resistor across IF inputs
IF Frequency	50		250	MHz	
VHF Local Oscillator					
Quaderature generation					
LO input Frequency	100		500	MHz	
VCO Phase noise		-100	-98	dBc/Hz	@30kHz, Hiband mode Minimum tank Q=15 Note 1
VCO Noise floor			-130	dBc/Hz	@>3MHz, Note 1
VCO buffer output	350			mV	pk-pk single ended
VCO buffer output impedance			100	Ω	Differential

Note 1: Phase noise is specified at the LO input to the mixers.

Electrical Characteristics (AC specifications) Continued

$T_{amb}=30^{\circ}C$ to $+70^{\circ}C$, $V_{CC}=+2.7$ to $+3.6$. These characteristics are guaranteed by either production test or design. They apply within the specified ambient temperature and supply voltage unless otherwise stated.

Characteristic	Value			Units	Conditions
	Min	Typ	Max		
Demodulator Output					I OUT, I OUTB, Q OUT, Q OUTB
I/Q Gain matching		0.1	0.25	dB	
I/Q Phase matching		0.5	2	deg	
Output impedance	3	4	5	k Ω	Differential
Baseband Bandwidth		50		MHz	Defined by on-chip first order low-pass filter
Output IP3	117	119		dB μ V	
Baseband differential DC offset			3.5	mV	
Overload Detect					Referred to baseband outputs
CDMA Mode		104		dB μ V	
FM Mode		106		dB μ V	

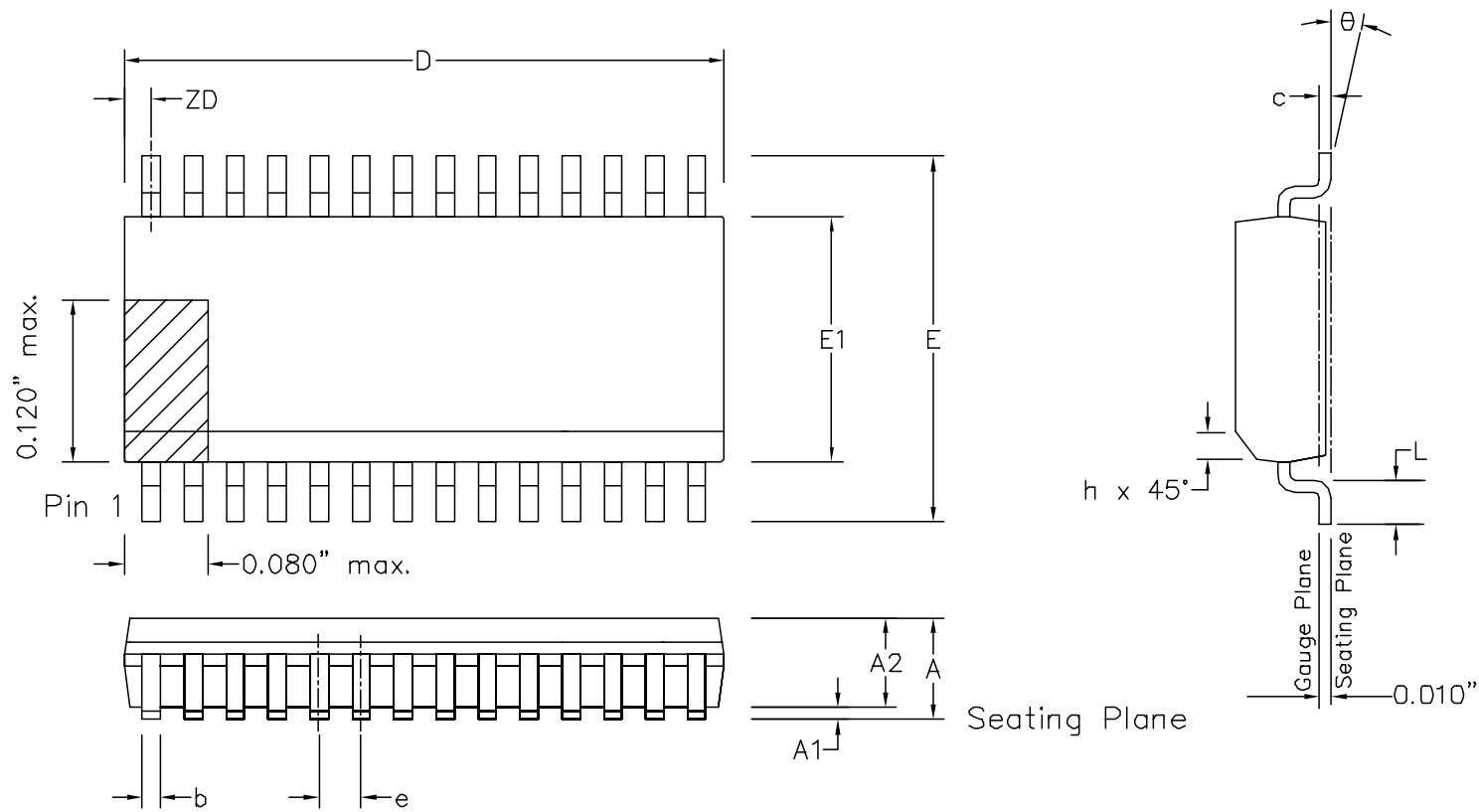

Symbol	Control Dimensions in inches		Altern. Dimensions in millimetres	
	MIN	MAX	MIN	MAX
A	0.053	0.069	1.35	1.75
A1	0.004	0.010	0.10	0.25
A2	—	0.059	—	1.50
D	0.386	0.394	9.80	10.01
ZD	0.033	REF.	0.84	REF.
E	0.228	0.244	5.79	6.20
E1	0.150	0.157	3.81	3.99
L	0.016	0.050	0.41	1.27
e	0.025	BSC.	0.64	BSC.
b	0.008	0.012	0.20	0.30
c	0.007	0.010	0.18	0.25
theta	0°	8°	0°	8°
h	0.010	0.020	0.25	0.50
Pin features				
N	28			
Conforms to JEDEC MO-137AF Iss. A				

This drawing supersedes
 418/ED/51617/004 (Swindon/Roborough)
 TD/D 1031 (Oldham)

Notes:

1. The chamfer on the body is optional. If it is not present, a visual index feature, e.g. a dot, must be located within the cross-hatched area.
2. Controlling dimensions are in inches.
3. Dimension D do not include mould flash, protrusion or gate burrs. These shall not exceed 0.006" per side.
4. Dimension E1 do not include inter-lead flash or protrusion. These shall not exceed 0.010" per side.
5. Dimension b does not include dambar protrusion/intrusion. Allowable dambar protrusion shall be 0.004" total in excess of b dimension.

© Mitel

ORIGINATING SITE: SWINDON

ISSUE	1	2			
ACN	201930	207316			
DATE	27FEB97	24AUG99			
APPRD.					

MITEL SEMICONDUCTOR

Title:
 Package Outline Drawing for
 28L QSOP-0.150" Body Width(QP)

Drawing Number

GPD00292



<http://www.mitelsemi.com>

World Headquarters - Canada

Tel: +1 (613) 592 2122
Fax: +1 (613) 592 6909

North America

Tel: +1 (770) 486 0194
Fax: +1 (770) 631 8213

Asia/Pacific

Tel: +65 333 6193
Fax: +65 333 6192

**Europe, Middle East,
and Africa (EMEA)**

Tel: +44 (0) 1793 518528
Fax: +44 (0) 1793 518581

Information relating to products and services furnished herein by Mitel Corporation or its subsidiaries (collectively "Mitel") is believed to be reliable. However, Mitel assumes no liability for errors that may appear in this publication, or for liability otherwise arising from the application or use of any such information, product or service or for any infringement of patents or other intellectual property rights owned by third parties which may result from such application or use. Neither the supply of such information or purchase of product or service conveys any license, either express or implied, under patents or other intellectual property rights owned by Mitel or licensed from third parties by Mitel, whatsoever. Purchasers of products are also hereby notified that the use of product in certain ways or in combination with Mitel, or non-Mitel furnished goods or services may infringe patents or other intellectual property rights owned by Mitel.

This publication is issued to provide information only and (unless agreed by Mitel in writing) may not be used, applied or reproduced for any purpose nor form part of any order or contract nor to be regarded as a representation relating to the products or services concerned. The products, their specifications, services and other information appearing in this publication are subject to change by Mitel without notice. No warranty or guarantee express or implied is made regarding the capability, performance or suitability of any product or service. Information concerning possible methods of use is provided as a guide only and does not constitute any guarantee that such methods of use will be satisfactory in a specific piece of equipment. It is the user's responsibility to fully determine the performance and suitability of any equipment using such information and to ensure that any publication or data used is up to date and has not been superseded. Manufacturing does not necessarily include testing of all functions or parameters. These products are not suitable for use in any medical products whose failure to perform may result in significant injury or death to the user. All products and materials are sold and services provided subject to Mitel's conditions of sale which are available on request.

M Mitel (design) and ST-BUS are registered trademarks of MITEL Corporation
Mitel Semiconductor is an ISO 9001 Registered Company
Copyright 1999 MITEL Corporation
All Rights Reserved
Printed in CANADA

TECHNICAL DOCUMENTATION - NOT FOR RESALE