

SINGLE PHASE BIDIRECTIONAL POWER/ENERGY METERING IC WITH SERIAL INTERFACE

FEATURES

- Performs bidirectional active power/energy measurement
- Meets the IEC 521/1036 Specification requirements for Class 1 AC Watt hour meters
- Protected against ESD
- Power consumption rating below 25mW
- Adaptable to different current sensor technologies
- Operates over a wide temperature range
- Serial interface having a RS232 protocol
- Precision voltage reference on-chip
- Tri-state output to allow parallel connection of devices.

DESCRIPTION

The SAMES SA9103E Single Phase bidirectional Power/Energy metering integrated circuit has a serial interface with a RS232 protocol, ideal for use with a μ -Controller. The SA9103E performs the calculation for active power.

The integrated value for active energy is accessible through the RS232-Interface as a 16 bit value.

This innovative universal single phase power/energy metering integrated circuit is ideally suited for energy calculations in applications such as electricity dispensing systems (ED's), residential municipal metering and factory energy metering and control.

The SA9103E integrated circuit is available in both 20 pin dual-in-line plastic (DIP-20), as well as 20 pin small outline (SOIC-20) package types.

PIN CONNECTIONS

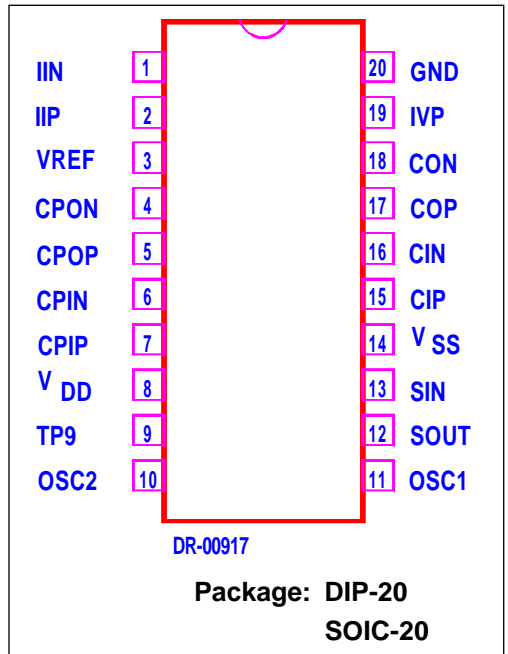

BLOCK DIAGRAM

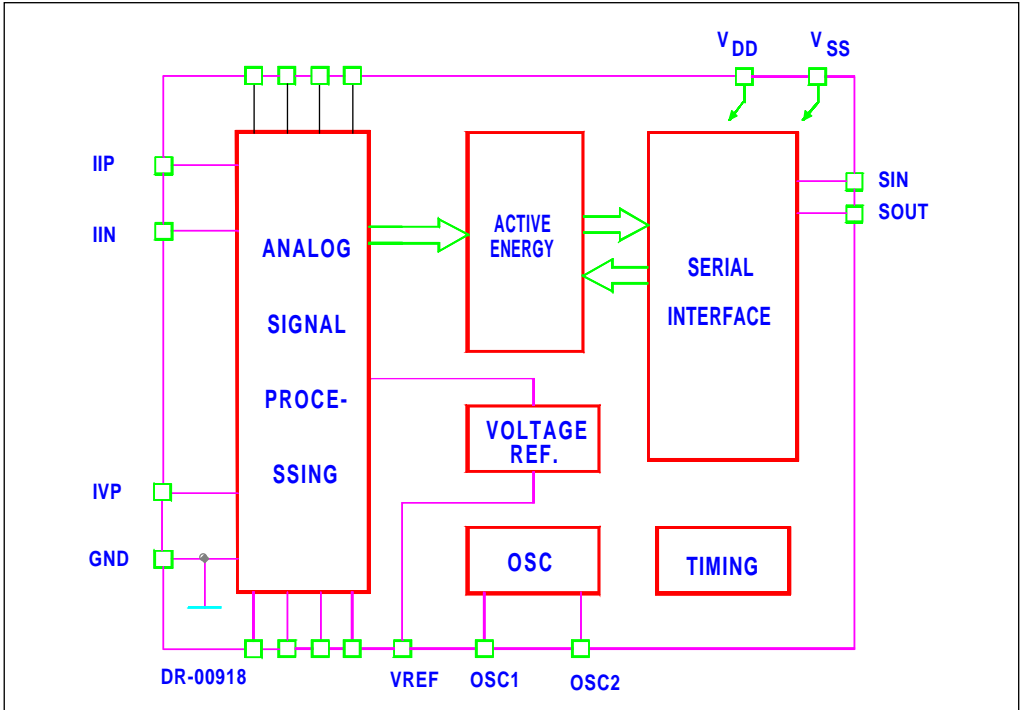

ABSOLUTE MAXIMUM RATINGS*

Parameter	Symbol	Min	Max	Unit
Supply Voltage	$V_{DD} - V_{SS}$	-0.3	6.0	V
Current on any pin	I_{PIN}	-150	+150	mA
Storage Temperature	T_{STG}	-40	+125	°C
Operating Temperature	T_O	-40	+85	°C

* Stresses above those listed under "Absolute Maximum Ratings" may cause permanent damage to the device. This is a stress rating only. Functional operation of the device at these or any other condition above those indicated in the operational sections of this specification, is not implied. Exposure to Absolute Maximum Ratings for extended periods may affect device reliability.

ELECTRICAL CHARACTERISTICS

($V_{DD} = 2.5V$, $V_{SS} = -2.5V$, over the temperature range $-10^{\circ}C$ to $+70^{\circ}C$ #, unless otherwise specified.)

Parameter	Symbol	Min	Typ	Max	Unit	Condition
Supply Voltage: Positive	V_{DD}	2.25		2.75	V	
Supply Voltage: Negative	V_{SS}	-2.75		-2.25	V	
Supply Current: Positive	I_{DD}		5	6	mA	
Supply Current: Negative	I_{SS}		5	6	mA	
Current Sensor Inputs (Differential)						
Input Current Range	I_{II}	-25		+25	μA	Peak value
Voltage Sensor Input (Asymmetrical)						
Input Current Range	I_{IV}	-25		+25	μA	Peak value
Pin SOUT Output Low Voltage Output High Voltage	V_{OL} V_{OH}	$V_{DD}-1$		$V_{SS}+1$	V V	$I_{OL} = 5mA$ $I_{OH} = -2mA$
Pin SIN High Voltage Low Voltage Pull-up Current	V_{IH} V_{IL} $-I_I$	$V_{DD}-1$ 50		$V_{SS}+1$ 150	V V μA	$V_{IN} = V_{SS}$
Oscillator	Recommended crystal: TV colour burst crystal $f = 3.5795$ MHz					
Pin VREF Ref. Current Ref. Voltage	$-I_R$ V_R	45 1.1	50	55 1.3	μA V	With $R = 24k\Omega$ connected to V_{SS} Referred to V_{SS}

Extended Operating Temperature Range available on request.



PIN DESCRIPTION

Pin	Designation	Description
20	GND	Ground
8	V _{DD}	Positive Supply Voltage
14	V _{SS}	Negative Supply Voltage
19	IVP	Analog input for Voltage
1	IIN	Inputs for current sensor
2	IIP	
11	OSC1	Connections for crystal or ceramic resonator (OSC1 = Input ; OSC2 = Output)
10	OSC2	
12	SOUT	Serial Interface Out
13	SIN	Serial Interface In
4	CPON	Connections for outer loop capacitors of A/D converter (Voltage)
5	CPOP	
6	CPIN	Connections for inner loop capacitors of A/D converter (Voltage)
7	CPIP	
15	CIP	Connections for inner loop capacitors of A/D converter (Current)
16	CIN	
17	COP	Connections for outer loop capacitors of A/D converter (Current)
18	CON	
3	VREF	Connection for current setting resistor
9	TP9	Test Pin. Connect to V _{SS}

FUNCTIONAL DESCRIPTION

The SA9103E is a CMOS mixed signal Analog/Digital integrated circuit, which performs power/energy calculations across a power range of 1000:1, to an overall accuracy of better than Class 1.

The integrated circuit includes all the required functions for 1-phase power and energy measurement, such as two oversampling A/D converters for the voltage and current sense inputs, power calculation and energy integration. Internal offsets are eliminated through the use of cancellation procedures. The SA9103E integrates the measured active power consumption into a 22 bit integrator, which is accessible via a serial port having a RS232 protocol.

1. Power calculation

In the Application Circuit (Figure 1), the voltage drop across the shunt will be between 0 and 16mV (0 to 80A through a shunt resistor of $200\mu\Omega$). This voltage is converted to a current of between 0 and $16\mu\text{A}$, by means of resistors R_1 and R_2 . The current sense input saturates at an input current of $\pm 25\mu\text{A}$ peak.

For the voltage sense input, the mains voltage (230VAC) is divided down through a divider to 14V. The resulting current into the A/D converter input is set at $14\mu\text{A}$ at nominal mains voltage, via resistor R_4 ($1\text{M}\Omega$).

In this configuration, with a mains voltage of 230V and a current of 80A, the SA9103E functions at its optimum conditions, having a margin of 3dB for overload available.

2. Analog Input Configuration

The input circuitry of the current and voltage sensor inputs are illustrated below. These inputs are protected against electrostatic discharge through clamping diodes.

The feedback loops from the outputs of the amplifiers A_I and A_V generate virtual shorts on the signal inputs. Exact duplications of the input currents are generated for the analog signal processing circuitry.

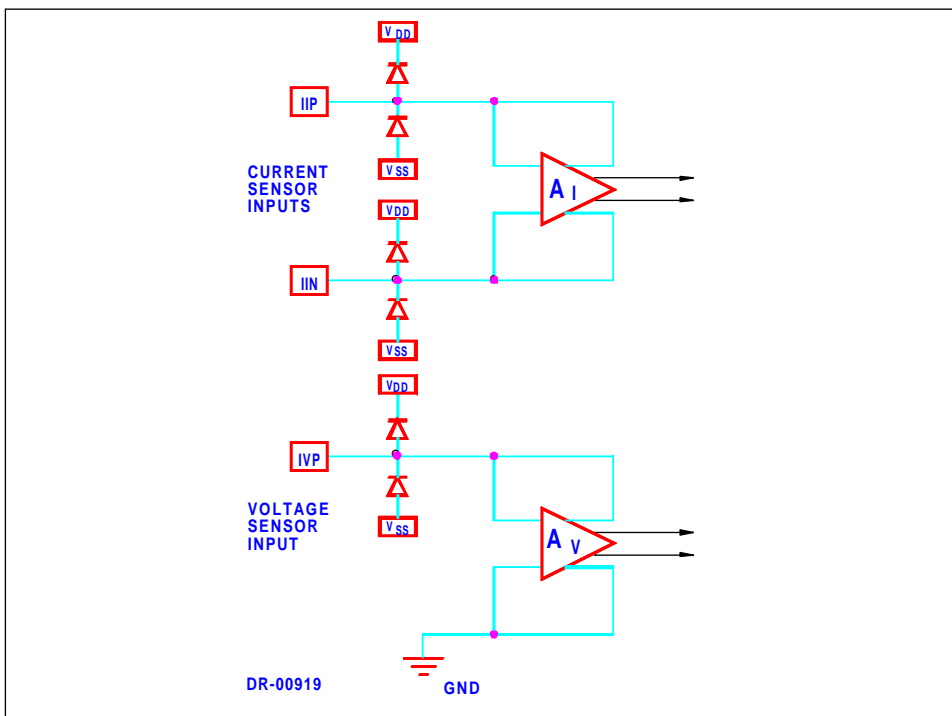

3. Electrostatic Discharge (ESD) Protection

The SA9103E integrated circuit's inputs/outputs are protected against ESD.

4. Power Consumption

The power consumption rating of the SA9103E integrated circuit is less than 25mW.

5. Serial Interface

Reading and resetting of the SA9103E's on-chip integrator, is performed via the serial interface.

The settings are:

- 19 200 Baud
- 1 Start bit (S)
- 1 Stop bit (E)
- No parity bits

The Serial Interface allows for the following operations:

Read Integrator: The SA9103E integrated circuit transmits the integrator status to the controller, after the current measurement cycle has been completed (8 mains periods maximum).

Reset Integrator: The SA9103E integrator is reset, without transmitting the integrator status.

Read/Reset Integrator): The SA9103E transmits the integrator status and resets the integrator after the current measurement cycle has been completed.

In a typical application, the system controller monitors the status of the SA9103E's integrator using the "Read" command. At rated load conditions, the capacity of the 22 bit integrator allows for an integration time of 2 seconds prior to integrator overflow.

If after a "Read" command, the integrator value is sufficiently high, a "Read/Reset" command from the controller causes the SA9103E integrated circuit to complete the existing measurement cycle, transmit the 16 most significant bits of the 22 bit integrator via the Serial Output (SOUT) to the controller and restart the integrator.

In order to ensure correct measurements, the integrator commands ("Read" and "Read/Reset") are only executed after completion of the internal offset calibration cycle. The cycle length is 8 mains periods.

Thus, for power calculations, the time value should be taken from the difference in time from the previously received energy value to the currently received value.

By adapting the "Read/Reset" rate to the line current the accuracy of the measurement can be achieved down to lowest signal levels.

Read, Reset and Read/Reset of integrator for active energy

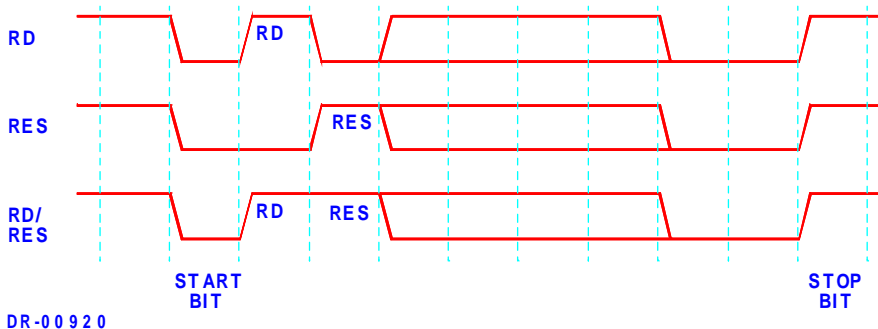

The register access codes which can be written to the SA9103E via the serial communications port are shown in the table below:

REGISTER	READ	RESET	READ-RESET
Active	\$01	\$02	\$03

From the two bytes of data output by the device, the value for the register may be derived as shown:

$$\text{Register value} = (\text{first byte} * 256) + \text{second byte}$$

The most significant bit of the 16 bit energy register is an indication fo the direction of the energy flow (0 = positive, 1 = negative)

Data on SOUT

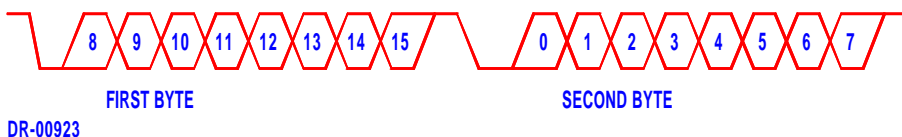

6. Register Values

The active energy measured per count, may be calculated by applying the following formula:

$$\text{Energy per Count} = \frac{VI}{K}$$

When V = Rated Voltage
 I = Rated Current
 K = 9281 for Active Energy

TYPICAL APPLICATIONS

In the Application Circuits (Figures 1 and 2) the components required for power metering applications, are shown.

In Figure 1, a shunt resistor is used for current sensing. In this application, the circuitry requires a +2.5V, 0V, -2.5V DC supply.

In the case of Figure 2, when using a current transformer for current sensing, a +5V, 0V DC supply is sufficient for the circuit.

The most important external components for the SA9103E integrated circuit are:

C_1 and C_2 are the outer loop capacitors for the two integrated oversampling A/D converters. The value of these capacitors is 560pF. The actual values determine the signal to noise and stability performance. The tolerances should be within $\pm 10\%$.

C_3 and C_4 are the inner loop capacitors of the A/D converters. The optimum value is 3.3nF. The actual values are uncritical. Values smaller than 0.5nF and larger than 5nF should be avoided.

R_1 , R_2 and RSH are the resistors defining the current level into the current sense input. The values should be selected for an input current of 16 μ A into the SA9103E at maximum line current.

Values for RSH of less than 200 $\mu\Omega$ should be avoided.

$$R_1 = R_2 = (I_L / 16\mu\text{A}) * \text{RSH} / 2$$

Where I_L = Line current

RSH = Shunt resistor/termination resistor

R_3 , R_6 and R_4 set the current for the voltage sense input. The values should be selected so that the input current into the voltage sense input (virtual ground) is set to 14 μ A.

R_7 defines all on-chip bias and reference currents. With $R_7 = 24\text{k}\Omega$, optimum conditions are set.



XTAL is a colour burst TV crystal ($f = 3.5795\text{MHz}$) for the oscillator. The oscillator frequency is divided down to 1.7897MHz on-chip, to supply the A/D converters and digital circuitry.

Figure 1: Application Circuit using a Shunt Resistor for Current Sensing, having a PC (Personal Computer) Interface.

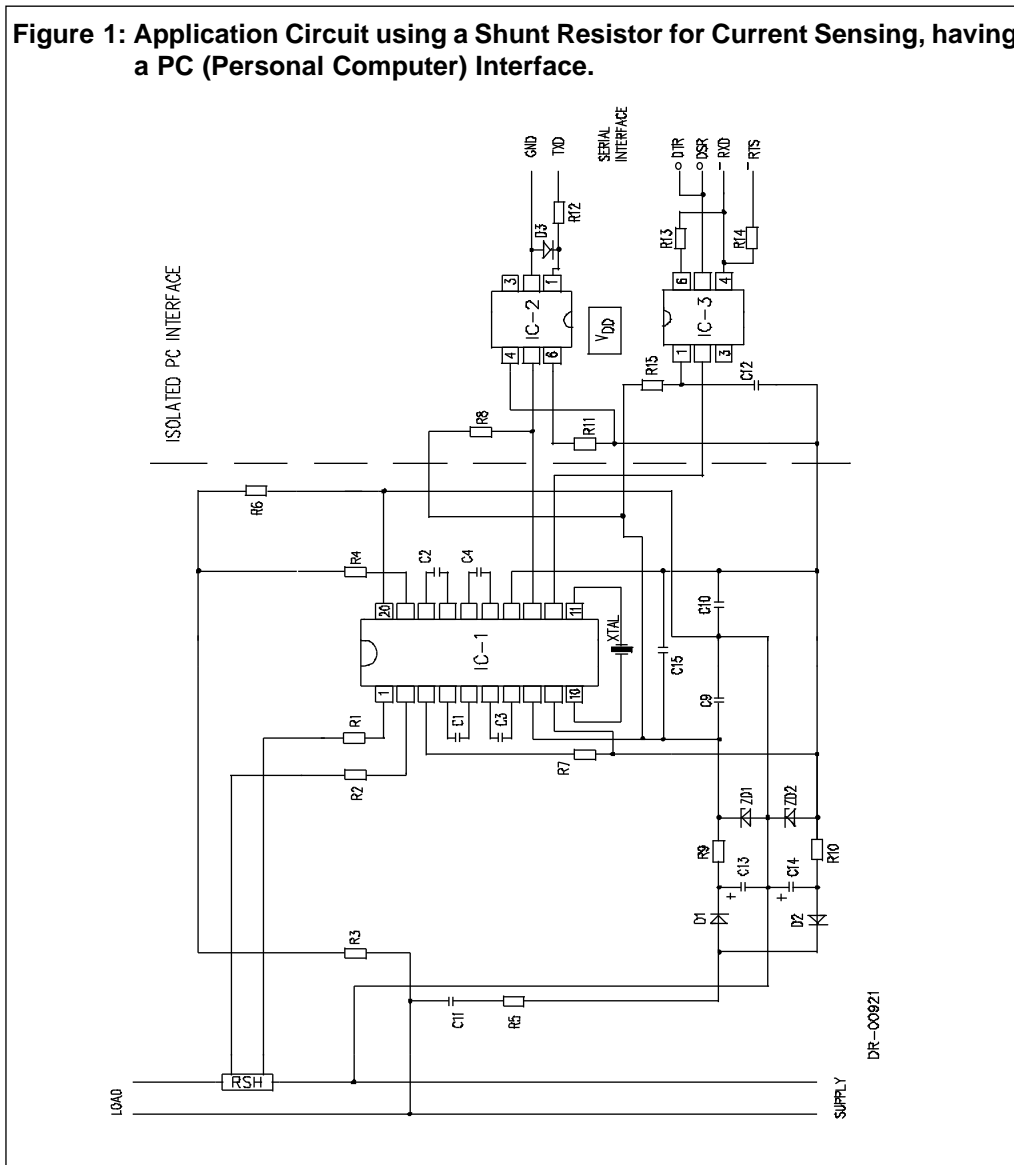

DR-00921

Note: The Serial Interface having a RS232 protocol, has been designed to operate directly with a PC (Personal Computer).

Part List for Application Circuit: Figure 1

Item	Symbol	Description	Detail
1	IC-1	SA9103E	DIP-20/SOIC-20
2	IC-2	Opto Coupler 4N35	DIP-6
3	IC-3	Opto Coupler 4N35	DIP-6
4	D1	Diode, Silicon, 1N4148	
5	D2	Diode, Silicon, 1N4148	
6	D3	Diode, Silicon, 1N4148	
7	ZD1	Diode, Zener, 2.4V, 200mW	
8	ZD2	Diode, Zener, 2.4V, 200mW	
9	XTAL	Crystal, 3.5795MHz	Colour burst TV
10	R1	Resistor, 1% metal	Note 1
11	R2	Resistor, 1% metal	Note 1
12	R3	Resistor, 390k, (230VAC), 1% metal	
13	R4	Resistor, 1M, 1/4W, 1% metal	
14	R5	Resistor, 470 Ω , 2W, 5%, carbon	
15	R6	Resistor, 24k, 1/4W, 1%, metal	
16	R7	Resistor, 24k, 1/4W, 1%, metal	
17	R8	Resistor, 680 Ω , 1/4W, 5%	
18	R9	Resistor, 680 Ω , 1/4W, 5%	
19	R10	Resistor, 680 Ω , 1/4W, 5%	
20	R11	Resistor, 100k, 1/4W, 5%	
21	R12	Resistor, 120 Ω , 1/4W, 5%	
22	R13	Resistor, 120k, 1/4W, 5%	
23	R14	Resistor, 3.9k, 1/4W, 5%	
24	R15	Resistor, 120 Ω , 1/4W, 5%	
25	C1	Capacitor, 560pF	
26	C2	Capacitor, 560pF	
27	C3	Capacitor, 3.3nF	
28	C4	Capacitor, 3.3nF	
29	C9	Capacitor, 100nF	
30	C10	Capacitor, 100nF	
31	C11	Capacitor, 0.47 μ F, 250VAC, polyester	
32	C12	Capacitor, 100nF	
33	C13	Capacitor, 100 μ F	
34	C14	Capacitor, 100 μ F	
35	C15	Capacitor, 820nF	
36	RSH	Shunt Resistor	Note 2

Note 1: Resistor (R1 and R2) values are dependant upon the selected value of RSH.

Note 2: See TYPICAL APPLICATIONS when selecting the value for RSH.



Figure 2: Application Circuit using a Current Transformer for Current Sensing.

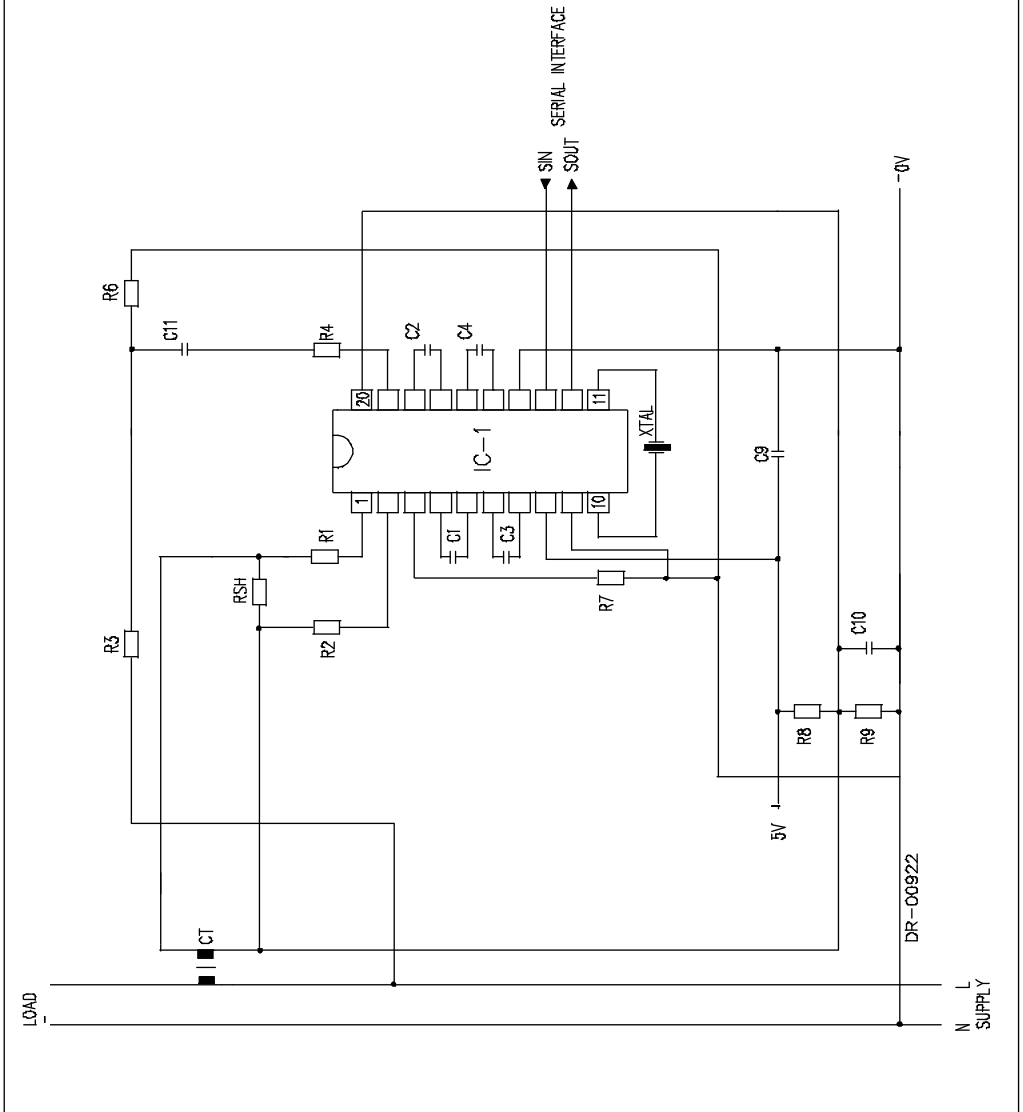

Parts List for Application Circuit: Figure 2

Item	Symbol	Description	Detail
1	IC-1	SA9103E	DIP-20/SOIC-20
2	XTAL	Crystal, 3.5795MHz	Colour burst TV
3	RSH	Resistor	Note 1
4	R1	Resistor, 1%, metal	Note 2
5	R2	Resistor, 1%, metal	Note 2
6	R3	Resistor, 390k, (230VAC) 1%, metal	
7	R4	Resistor, 1M, 1/4W, metal	
8	R6	Resistor, 24k, 1/4W, metal	
9	R7	Resistor, 24k, 1/4W, metal	
10	R8	Resistor, 2.2k, 1/4W, 5%	
11	R9	Resistor, 2.2k, 1/4W, 5%	
12	C1	Capacitor, 560pF	
13	C2	Capacitor, 560pF	
14	C3	Capacitor, 3.3nF	
15	C4	Capacitor, 3.3nF,	
16	C9	Capacitor, 820nF	Note 3
17	C10	Capacitor, 100nF	
18	C11	Capacitor	Note 4
19	CT	Current transformer	

Note 1: See TYPICAL APPLICATIONS when selecting the value of RSH.

Note 2: Resistor (R1 and R2) values are dependant upon the selected value of RSH.

Note 3: Capacitor (C9) to be positioned as close to IC-1, as possible.

Note 4: Capacitor (C11) selected for DC blocking and to minimize phase error introduced by the current transformer.

ORDERING INFORMATION

Part Number	Package
SA9103EPA	DIP-20
SA9103ESA	SOIC-20

NOTES:

Disclaimer: The information contained in this document is confidential and proprietary to South African Micro-Electronic Systems (Pty) Ltd ("SAMES") and may not be copied or disclosed to a third party, in whole or in part, without the express written consent of SAMES. The information contained herein is current as of the date of publication; however, delivery of this document shall not under any circumstances create any implication that the information contained herein is correct as of any time subsequent to such date. SAMES does not undertake to inform any recipient of this document of any changes in the information contained herein, and SAMES expressly reserves the right to make changes in such information, without notification, even if such changes would render information contained herein inaccurate or incomplete. SAMES makes no representation or warranty that any circuit designed by reference to the information contained herein, will function without errors and as intended by the designer.

Any Sales or technical questions may be posted to our e-mail address below:
energy@sames.co.za

For the latest updates on datasheets, please visit our web site:
<http://www.sames.co.za>

South African Micro-Electronic Systems (Pty) Ltd

P O Box 15888,
Lynn East,
0039
Republic of South Africa,

33 Eland Street,
Koedoespoort Industrial Area,
Pretoria,
Republic of South Africa

Tel: 012 333-6021

Fax: 012 333-8071

Tel: Int +27 12 333-6021

Fax: Int +27 12 333-8071

