

**SCHOTTKY RECTIFIER**  
*New GenIII D-61 Package*

80 Amp

**Major Ratings and Characteristics**

Characteristics	Values	Units
$I_{F(AV)}$ Rectangular waveform	80	A
$V_{RRM}$ range	35 to 45	V
$I_{FSM}$ @tp = 5 $\mu$ s sine	5800	A
$V_F$ @40 Apk, $T_J = 125^\circ\text{C}$ (per leg)	0.47	V
$T_J$ range	-55 to 150	$^\circ\text{C}$

**Description/ Features**

The center tap Schottky rectifier module series has been optimized for very low forward voltage drop, with moderate leakage. The proprietary barrier technology allows for reliable operation up to 150 $^\circ\text{C}$  junction temperature. Typical applications are in switching power supplies, converters, free-wheeling diodes, and reverse battery protection.

- 150 $^\circ\text{C}$   $T_J$  operation
- Center tap module
- Very low forward voltage drop
- High purity, high temperature epoxy encapsulation for enhanced mechanical strength and moisture resistance
- High frequency operation
- Guard ring for enhanced ruggedness and long term reliability
- *New fully transfer-mould low profile, small footprint, high current package*
- Through-hole versions are currently available for use in Lead-Free applications ("PbF" suffix)

**Case Styles**

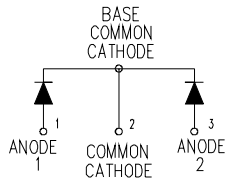
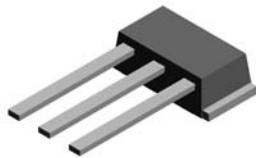
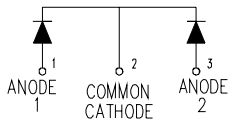
<p>80CNQ...APbF</p>  <div style="text-align: center;">  <p><b>D61-8</b></p> </div>	<p>80CNQ...ASMPbF</p>  <div style="text-align: center;">  <p><b>D61-8-SM</b></p> </div>
--	---

## Voltage Ratings

Part number	80CNQ035A..	80CNQ040A..	80CNQ045A..
$V_R$ Max. DC Reverse Voltage (V)	35	40	45
$V_{RWM}$ Max. Working Peak Reverse Voltage (V)			

## Absolute Maximum Ratings

Parameters	80CNQ	Units	Conditions
$I_{F(AV)}$ Max. Average Forward (Per Leg) Current * See Fig. 5 (Per Device)	40 80	A	50% duty cycle @ $T_C = 114^\circ\text{C}$ , rectangular wave form
$I_{FSM}$ Max. Peak One Cycle Non-Repetitive Surge Current (Per Leg) * See Fig. 7	5800 750	A	5 $\mu\text{s}$ Sine or 3 $\mu\text{s}$ Rect. pulse 10ms Sine or 6ms Rect. pulse Following any rated load condition and with rated $V_{RWM}$ applied
$E_{AS}$ Non-Repetitive Avalanche Energy (Per Leg)	54	mJ	$T_J = 25^\circ\text{C}$ , $I_{AS} = 8$ Amps, $L = 1.7$ mH
$I_{AR}$ Repetitive Avalanche Current (Per Leg)	8	A	Current decaying linearly to zero in 1 $\mu\text{sec}$ Frequency limited by $T_J$ max. $V_A = 1.5 \times V_R$ typical

## Electrical Specifications

Parameters	80CNQ	Units	Conditions
$V_{FM}$ Max. Forward Voltage Drop (Per Leg) * See Fig. 1 (1)	0.52	V	@ 40A $T_J = 25^\circ\text{C}$
	0.66	V	@ 80A
	0.47	V	@ 40A $T_J = 125^\circ\text{C}$
	0.61	V	@ 80A
$I_{RM}$ Max. Reverse Leakage Current (Per Leg) * See Fig. 2 (1)	5	mA	$T_J = 25^\circ\text{C}$
	250	mA	$T_J = 125^\circ\text{C}$ $V_R = \text{rated } V_R$
$V_{F(TO)}$ Threshold Voltage	0.26	V	$T_J = T_J \text{ max.}$
$r_t$ Forward Slope Resistance	3.93	m $\Omega$	
$C_T$ Max. Junction Capacitance (Per Leg)	2600	pF	$V_R = 5V_{DC}$ (test signal range 100Khz to 1Mhz) $25^\circ\text{C}$
$L_s$ Typical Series Inductance (Per Leg)	5.5	nH	Measured lead to lead 5mm from package body
$dv/dt$ Max. Voltage Rate of Change (Rated $V_R$ )	10000	V/ $\mu\text{s}$	

(1) Pulse Width < 300 $\mu\text{s}$ , Duty Cycle <2%

## Thermal-Mechanical Specifications

Parameters	80CNQ	Units	Conditions
$T_J$ Max. Junction Temperature Range	-55 to 150	$^\circ\text{C}$	
$T_{stg}$ Max. Storage Temperature Range	-55 to 150	$^\circ\text{C}$	
$R_{thJC}$ Max. Thermal Resistance Junction to Case (Per Leg)	0.85	$^\circ\text{C}/\text{W}$	DC operation *See Fig. 4
$R_{thJC}$ Max. Thermal Resistance Junction to Case (Per Package)	0.42	$^\circ\text{C}/\text{W}$	DC operation
$R_{thCS}$ Typical Thermal Resistance, Case to Heatsink (D61-8 Only)	0.30	$^\circ\text{C}/\text{W}$	Mounting surface, smooth and greased Device flatness < 5 mils
wt Approximate Weight	7.8 (0.28)	g (oz.)	
T Mounting Torque (D61-8 Only)	Min.	40 (35)	Kg -cm (lbf-in)
	Max.	58 (50)	

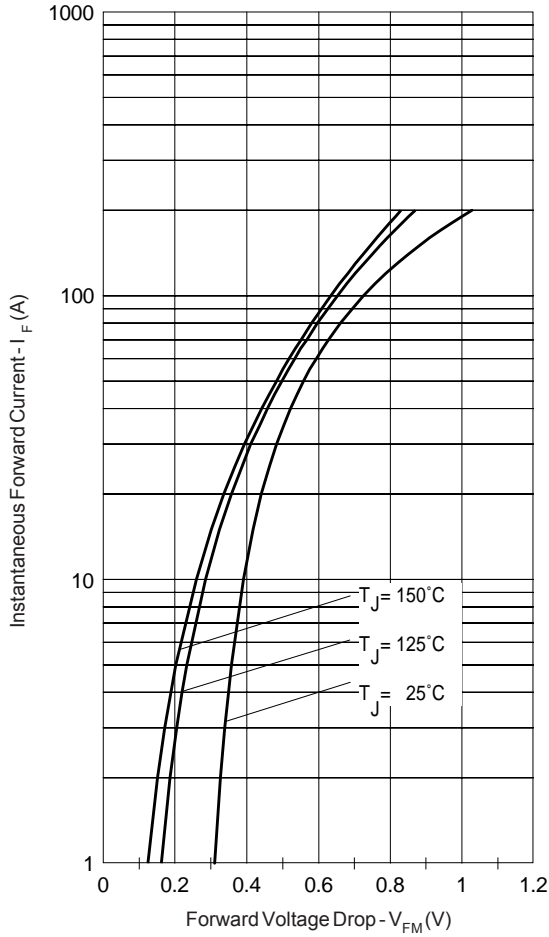

Fig. 1 - Max. Forward Voltage Drop Characteristics (Per Leg)

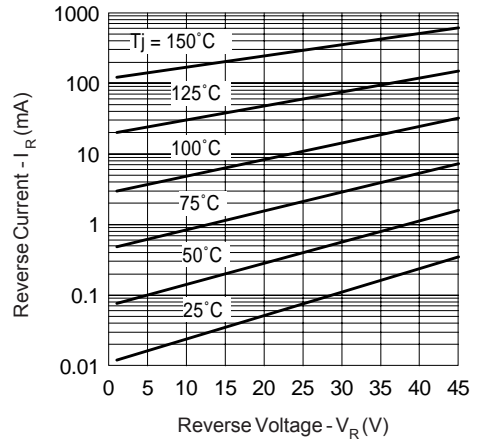

Fig. 2 - Typical Values Of Reverse Current Vs. Reverse Voltage (Per Leg)

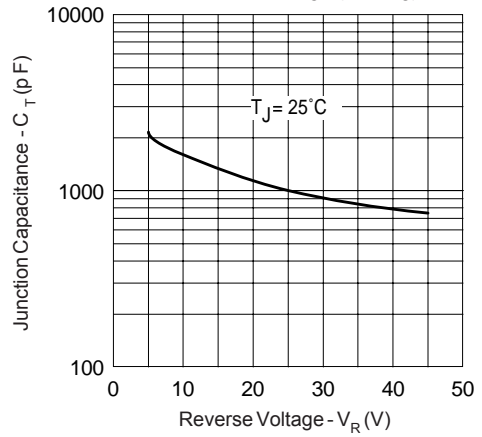

Fig. 3 - Typical Junction Capacitance Vs. Reverse Voltage (Per Leg)

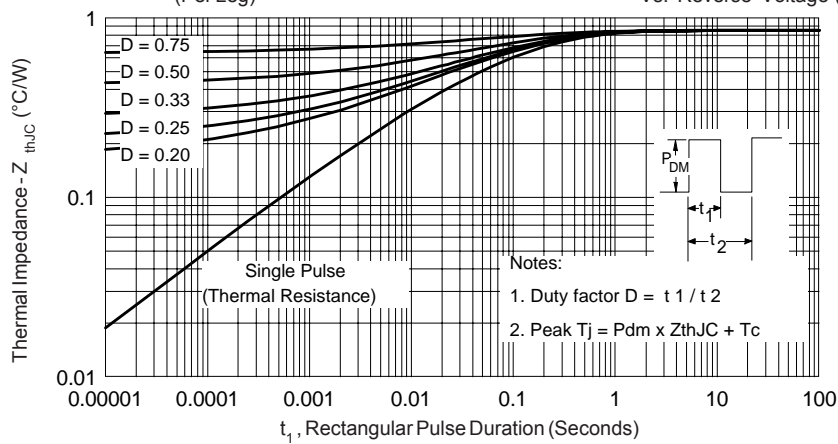

Fig. 4 - Max. Thermal Impedance  $Z_{thJC}$  Characteristics (Per Leg)

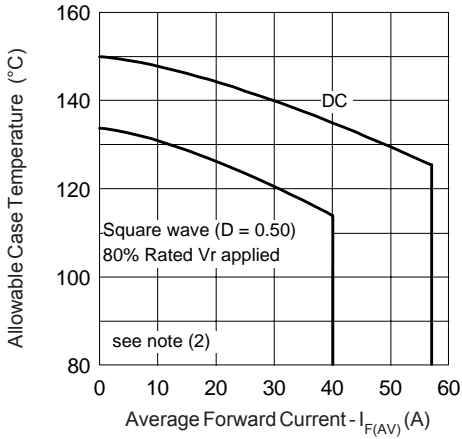

Fig. 5 - Max. Allowable Case Temperature Vs. Average Forward Current (Per Leg)

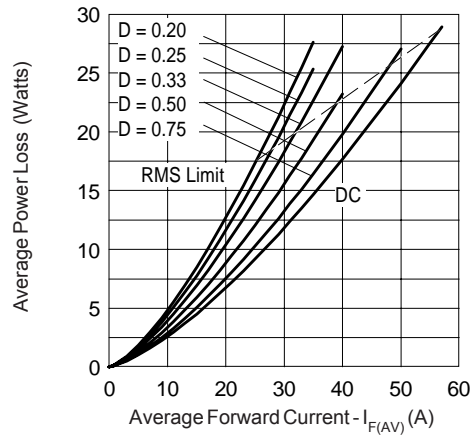

Fig. 6 - Forward Power Loss Characteristics (Per Leg)

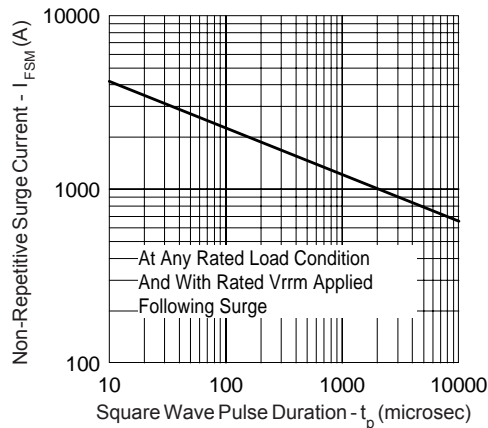

Fig. 7 - Max. Non-Repetitive Surge Current (Per Leg)

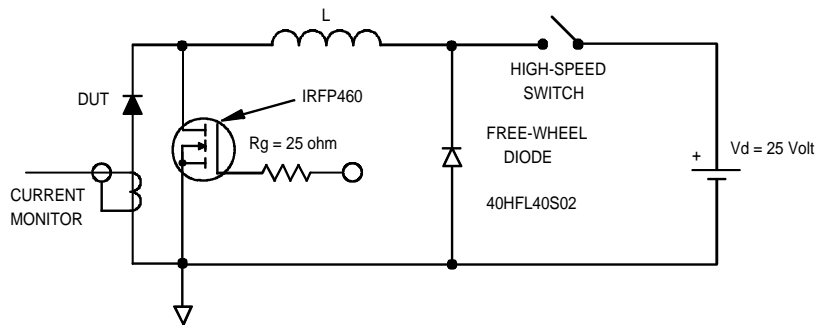

Fig. 8 - Unclamped Inductive Test Circuit

(2) Formula used:  $T_C = T_J - (P_d + P_{d_{REV}}) \times R_{thJC}$ ;

$P_d = \text{Forward Power Loss} = I_{F(AV)} \times V_{FM} @ (I_{F(AV)} / D)$  (see Fig. 6);

$P_{d_{REV}} = \text{Inverse Power Loss} = V_{R1} \times I_{R1} (1 - D)$ ;  $I_{R1} @ V_{R1} = 80\% \text{ rated } V_R$

Outline Table

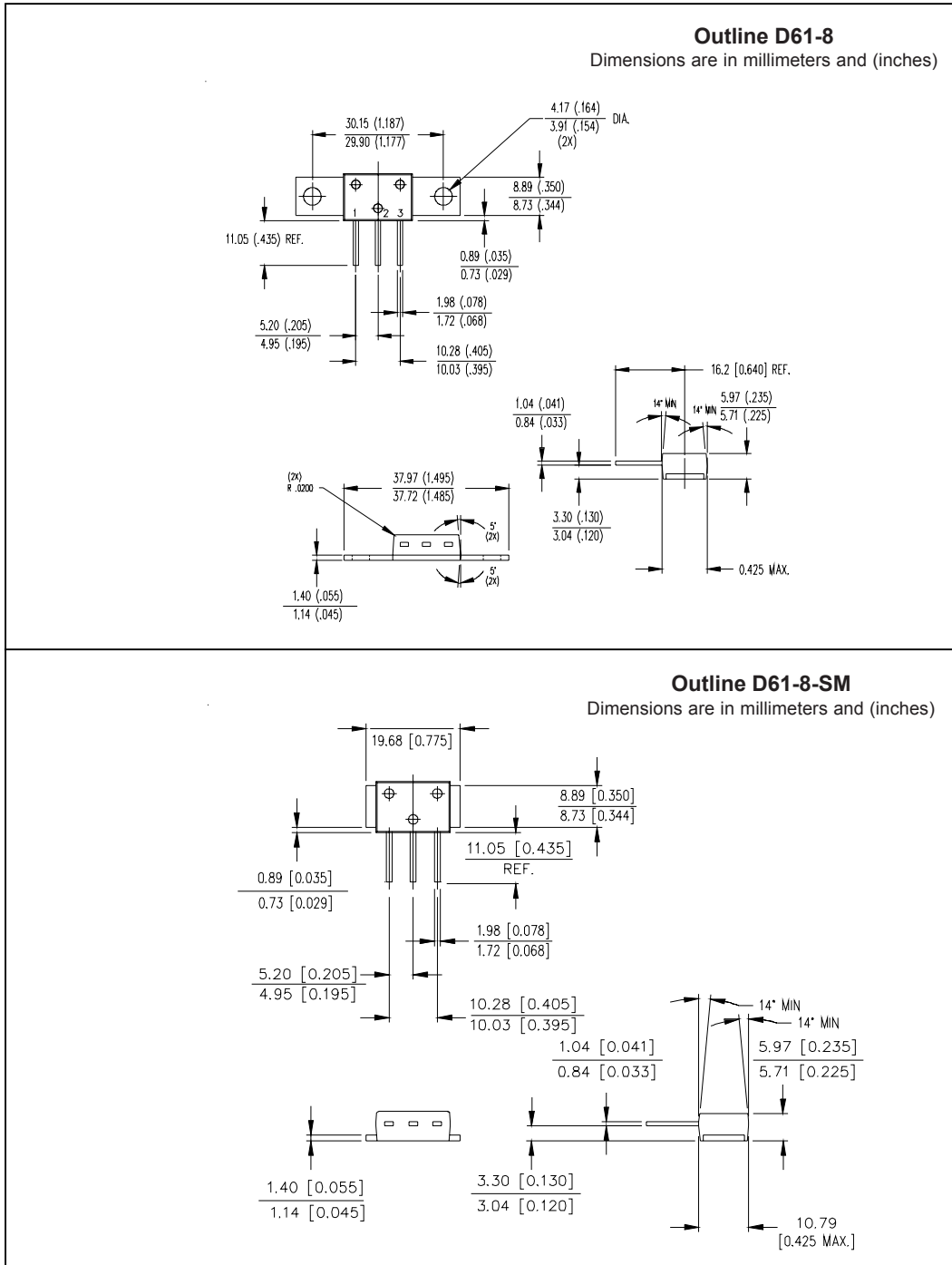

**Outline D61-8-SM**  
 Dimensions are in millimeters and (inches)

### Part Marking Information

**D61-8**

EXAMPLE: THIS IS A 80CNQ045 WITH  
LOT CODE 89 09  
ASSEMBLED ON WW 45, 2000

Note: "P" in assembly line  
position indicates "Lead-Free"

INTERNATIONAL RECTIFIER LOGO

PART NUMBER

80CNQ045A

89 09 045P

ASSEMBLY LOT CODE

DATE CODE  
YEAR 0 = 2000  
WEEK 45  
P = LEAD-FREE

**D61-8-SM**

EXAMPLE: THIS IS A 80CNQ045ASM WITH  
LOT CODE 89 09  
ASSEMBLED ON WW 45, 2000

Note: "P" in assembly line  
position indicates "Lead-Free"

INTERNATIONAL RECTIFIER LOGO

PART NUMBER

80CNQ045ASM

89 09 045P

ASSEMBLY LOT CODE

DATE CODE  
YEAR 0 = 2000  
WEEK 45  
P = LEAD-FREE

Ordering Information Table

Device Code	
80	C
N	Q
045	A
PbF	
①	②
③	④
⑤	⑥
⑦	

<p><b>1</b> - Current Rating (80A)</p> <p><b>2</b> - Circuit Configuration C = Common Cathode</p> <p><b>3</b> - Package N = D-61</p> <p><b>4</b> - Schottky "Q" Series</p> <p><b>5</b> - Voltage Ratings</p> <p><b>6</b> -</p> <ul style="list-style-type: none"> <li>• A = D-61-8 package style</li> <li>• ASM = D-61-8-SM package style</li> </ul> <p><b>7</b> -</p> <ul style="list-style-type: none"> <li>• none = Standard Production</li> <li>• PbF = Lead-Free</li> </ul>	<table border="1" style="border-collapse: collapse;"> <tr> <td style="padding: 2px;">035 = 35V</td> </tr> <tr> <td style="padding: 2px;">040 = 40V</td> </tr> <tr> <td style="padding: 2px;">045 = 45V</td> </tr> </table>	035 = 35V	040 = 40V	045 = 45V
035 = 35V				
040 = 40V				
045 = 45V				

Standard pack quantity: A = 10 pieces  
 ASM = 20 pieces

Data and specifications subject to change without notice.  
 This product has been designed and qualified for Industrial Level and Lead-Free.  
 Qualification Standards can be found on IR's Web site.