

FEATURES

- 5V power supply options
- High bandwidth output transitions
- Internal 75KΩ pull-down resistors on inputs
- Functionally equivalent to SY10/100EL16V with variable output swing
- Improved output waveform characteristics
- ESD protection of 2000V
- Available in 8-pin (3mm) TSSOP

PIN CONFIGURATION/BLOCK DIAGRAM

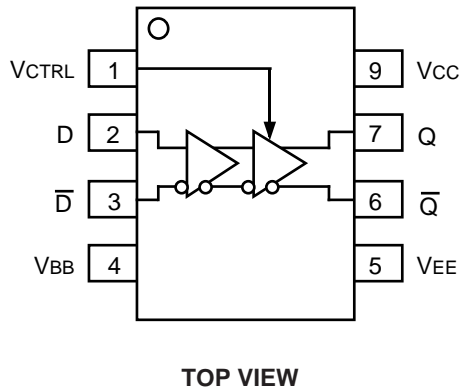

DESCRIPTION

The SY100EL16S is a differential receiver with variable output swing. This device is functionally equivalent to the EL16V, with an additional input that control the output amplitude.

The operating range of the EL16S control input is from VBB (max. swing) to VCC (min. swing). Control of the output swing can be obtained by a variable resistor between the VBB pin and VCC with the wiper driving VCTRL.

The EL16S provides a VBB output for either single-ended use or as a DC bias for AC coupling to the device. The VBB pin should be used only as a bias for the EL16S as its current sink/source capability is limited. Whenever used, the VBB pin should be bypassed to VCC via a 0.01μF capacitor.

Under open input conditions (pulled to VEE), internal input clamps will force the Q output LOW.

PIN NAMES

Pin	Function
D, \bar{D}	Data Inputs
Q, \bar{Q}	Data Outputs
VBB	Reference Voltage Output
VCTRL	Output Swing Control

TYPICAL VOLTAGE OUTPUT SWING

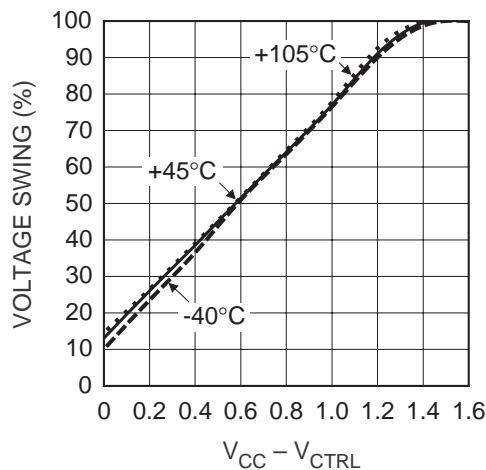

Figure 1. Typical Voltage Output Swing
VCC = 5V

DC ELECTRICAL CHARACTERISTICS⁽¹⁾

$V_{EE} = V_{EE} (\text{Min.})$ to $V_{EE} (\text{Max.})$; $V_{CC} = \text{GND}$

Symbol	Parameter	$T_A = -40^\circ\text{C}$			$T_A = 0^\circ\text{C}$			$T_A = +25^\circ\text{C}$			$T_A = +85^\circ\text{C}$			Unit
		Min.	Typ.	Max.	Min.	Typ.	Max.	Min.	Typ.	Max.	Min.	Typ.	Max.	
I _{EE}	Power Supply Current	—	—	22	—	—	22	9	18	22	9	21	26	mA
V _{BB}	Output Reference Voltage	-1.38	—	-1.26	-1.38	—	-1.26	-1.38	—	-1.26	-1.38	—	-1.26	V
I _{IH}	Input HIGH Current	—	—	150	—	—	150	—	—	150	—	—	150	μA
	—D, \bar{D} —V _{CTRL}	—	—	40	—	—	40	—	—	40	—	—	40	

NOTE:

- Parametric values specified at: 100EL16S Series: -4.5V to -5.5V .

AC ELECTRICAL CHARACTERISTICS⁽¹⁾

$V_{EE} = V_{EE} (\text{Min.})$ to $V_{EE} (\text{Max.})$; $V_{CC} = \text{GND}$

Symbol	Parameter	$T_A = -40^\circ\text{C}$			$T_A = 0^\circ\text{C}$			$T_A = +25^\circ\text{C}$			$T_A = +85^\circ\text{C}$			Unit
		Min.	Typ.	Max.	Min.	Typ.	Max.	Min.	Typ.	Max.	Min.	Typ.	Max.	
t _{PLH}	Propagation Delay to Output D (Diff)	175	—	325	175	—	325	175	—	325	205	—	355	ps
t _{PHL}	Delay to Output D (SE)	125	250	425	125	250	375	125	250	375	125	280	405	
t _{skew}	Duty Cycle Skew ⁽²⁾ (Diff)	—	5	—	—	5	20	—	5	20	—	5	20	ps
V _{PP}	Minimum Input Swing ⁽³⁾	150	—	—	150	—	—	150	—	—	150	—	—	mV
V _{CMR}	Common Mode Range ⁽⁴⁾	-1.3	—	-0.4	-1.4	—	-0.4	-1.4	—	-0.4	-1.4	—	-0.4	V
V _{OL}	Output LOW Voltage ⁽⁵⁾ V _{CTRL} = V _{BB}	-1890	—	-1620	-1870	—	-1680	-1870	-1775	-1680	-1870	—	-1680	mV
V _{OL}	Output LOW Voltage ⁽⁵⁾ V _{CTRL} = V _{CC}	-1180	—	-975	-1135	—	-990	-1135	-1065	-990	-1135	—	-990	mV
V _{OH}	Output HIGH Voltage ⁽⁶⁾	-1085	—	-880	-1025	—	-880	-1025	-955	-880	-1025	—	-880	mV
t _r t _f	Output Rise/Fall Times Q (20% to 80%)	—	—	350	—	—	350	—	—	350	—	—	350	ps

NOTES:

- Parametric values specified at: 100EL16S Series: -4.5V to -5.5V .
- Duty cycle skew is the difference between a t_{PLH} and t_{PHL} propagation delay through a device.
- Minimum input swing for which AC parameters are guaranteed. The device has a DC gain of ≈ 40 when output has a full swing.
- The CMR range is referenced to the most positive side of the differential input signal. Normal operation is obtained if the HIGH level falls within the specified range and the peak-to-peak voltage lies between V_{PP} min. and 1V. The lower end of the CMR range varies 1:1 with V_{EE}. The numbers in the spec table assume a nominal V_{EE} = -3.3V . Note for PECL operation, the V_{CMR} (min) will be fixed at $3.3\text{V} - |V_{\text{CMR}} (\text{min})|$.
- If V_{CTRL} is Open Circuit, use the V_{OH} (max. & min.) and V_{OL} (V_{CTRL} = V_{BB}: max only) limits.
- V_{CC} ≥ V_{CTRL} ≥ V_{EE}

PRODUCT ORDERING CODE

Ordering Code	Package Type	Operating Range	V _{EE} Range (V)
SY100EL16SKC	K8-1	Commercial	-4.5 to -5.5
SY100EL16SZC	Z8-1	Commercial	-4.5 to -5.5

APPLICATION IMPLEMENTATION

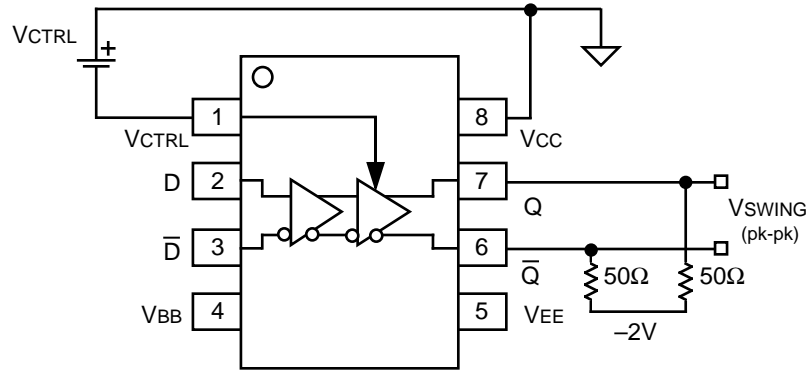

Figure 2. Voltage Source Implementation

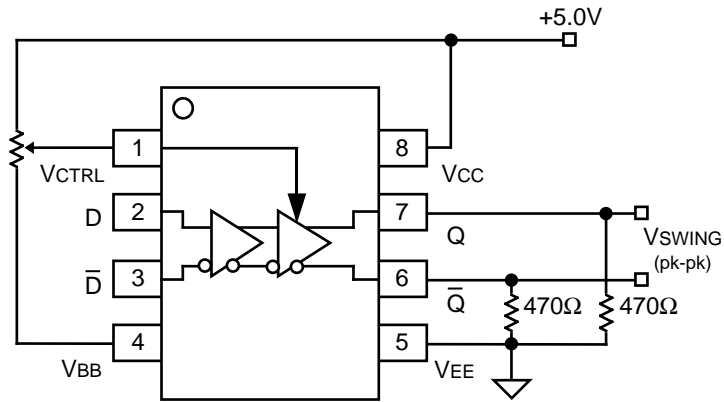
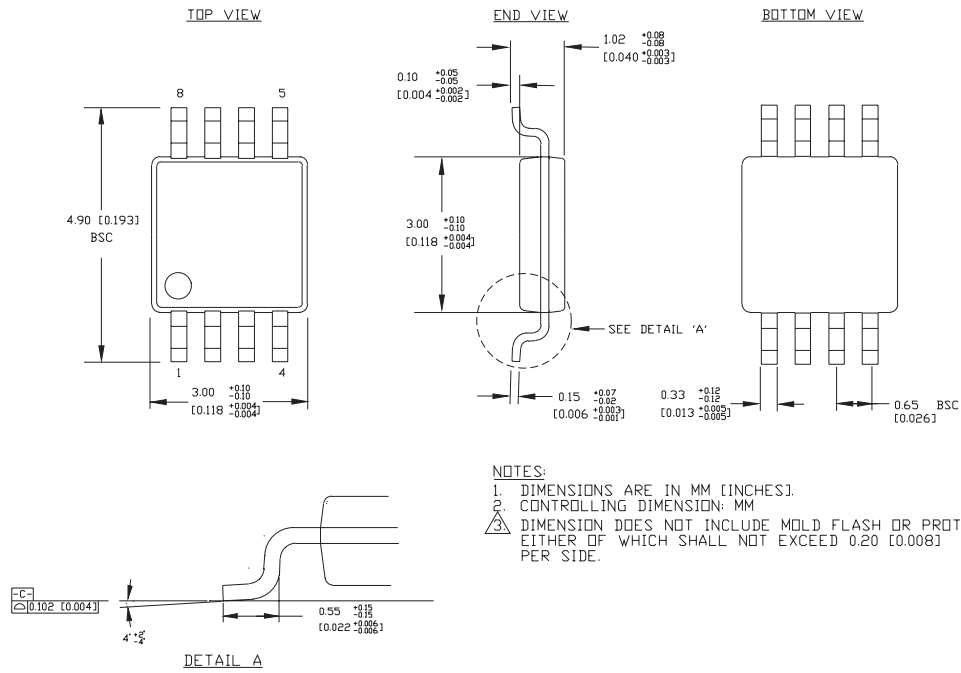

Figure 3. Alternative Implementation

8 LEAD TSSOP (K8-1)



NOTES:
1. DIMENSIONS ARE IN MM [INCHES].
2. CONTROLLING DIMENSION: MM
⚠ DIMENSION DOES NOT INCLUDE MOLD FLASH OR PROTRUSIONS, EITHER OF WHICH SHALL NOT EXCEED 0.20 [0.008] PER SIDE.

8 LEAD PLASTIC SOIC (Z8-1)

TOP VIEW

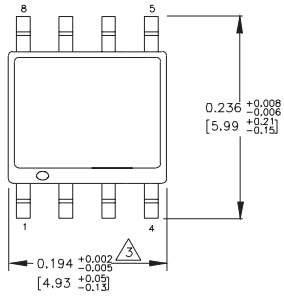

END VIEW

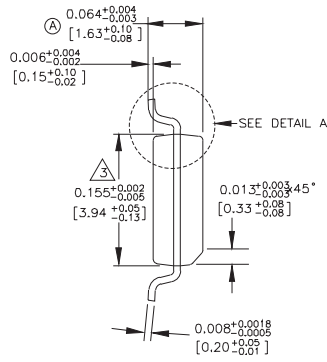

BOTTOM VIEW

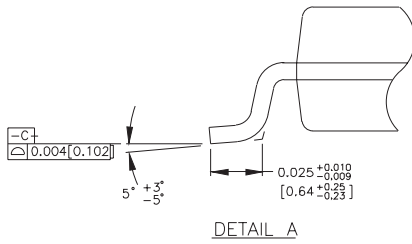
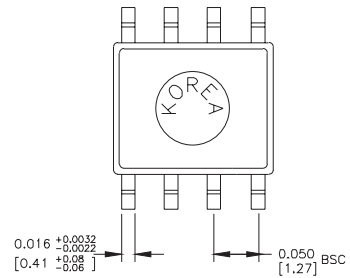

NOTES:

1. DIMENSIONS ARE IN INCHES[MM].
2. CONTROLLING DIMENSION: INCHES.
3. DIMENSION DOES NOT INCLUDE MOLD FLASH OR PROTRUSIONS, EITHER OF WHICH SHALL NOT EXCEED 0.006[0.152] PER SIDE.