

T.33-35

SGS-THOMSON

NPN DARLINGTON POWER MODULE

- HIGH CURRENT POWER BIPOLAR MODULE
- VERY LOW R_{th} JUNCTION CASE
- SPECIFIED ACCIDENTAL OVERLOAD AREAS
- ULTRAFAST FREEWHEELING DIODE
- ISOLATED CASE (2500V RMS)
- EASY TO MOUNT
- LOW INTERNAL PARASITIC INDUCTANCE

INDUSTRIAL APPLICATIONS:

- MOTOR CONTROL
- SMPS & UPS
- WELDING EQUIPMENT

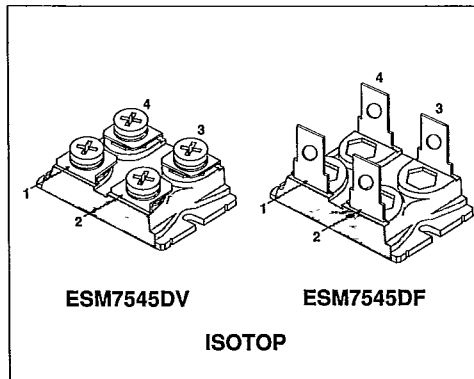

ESM7545DV

ESM7545DF

ISOTOP

INTERNAL SCHEMATIC DIAGRAM

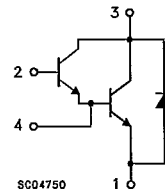

ABSOLUTE MAXIMUM RATINGS

Symbol	Parameter	Value	Unit
V_{CEV}	Collector-Emitter Voltage ($V_{BE} = -5$ V)	600	V
$V_{CEO(sus)}$	Collector-Emitter Voltage ($I_B = 0$)	450	V
V_{EBO}	Emitter-Base Voltage ($I_C = 0$)	7	V
I_C	Collector Current	75	A
I_{CM}	Collector Peak Current ($t_p = 10$ ms)	112	A
I_B	Base Current	5	A
I_{BM}	Base Peak Current ($t_p = 10$ ms)	7	A
P_{tot}	Total Dissipation at $T_c = 25$ °C	250	W
T_{stg}	Storage Temperature	-55 to 150	°C
T_j	Max. Operating Junction Temperature	150	°C
V_{ISO}	Insulation Withstand Voltage (AC-RMS)	2500	V

THERMAL DATA

T-33-35

$R_{thj-case}$	Thermal Resistance Junction-case (transistor)	Max	0.5	$^{\circ}\text{C/W}$
$R_{thj-case}$	Thermal Resistance Junction-case (diode)	Max	1.1	$^{\circ}\text{C/W}$
R_{thc-h}	Thermal Resistance Case-heatsink With Conductive Grease Applied	Max	0.05	$^{\circ}\text{C/W}$

ELECTRICAL CHARACTERISTICS ($T_{case} = 25^{\circ}\text{C}$ unless otherwise specified)

Symbol	Parameter	Test Conditions	Min.	Typ.	Max.	Unit
I_{CER} #	Collector Cut-off Current ($R_{BE} = 5 \Omega$)	$V_{CE} = V_{CEV}$			2	mA
		$V_{CE} = V_{CEV} \quad T_j = 100^{\circ}\text{C}$			25	mA
I_{CEV} #	Collector Cut-off Current ($V_{BE} = -5$)	$V_{CE} = V_{CEV}$			2	mA
		$V_{CE} = V_{CEV} \quad T_j = 100^{\circ}\text{C}$			25	mA
I_{EBO} #	Emitter Cut-off Current ($I_C = 0$)	$V_{EB} = 5 \text{ V}$			200	mA
$V_{CE(sus)}^*$	Collector-Emitter Sustaining Voltage	$I_C = 0.2 \text{ A} \quad L = 25 \text{ mH}$ $V_{clamp} = 450 \text{ V}$	450			V
h_{FE}^*	DC Current Gain	$I_C = 75 \text{ A} \quad V_{CE} = 5 \text{ V}$		500		
$V_{CE(sat)}^*$	Collector-Emitter Saturation Voltage	$I_C = 50 \text{ A} \quad I_B = 1 \text{ A}$		1.3		V
		$I_C = 50 \text{ A} \quad I_B = 1 \text{ A} \quad T_j = 100^{\circ}\text{C}$		1.5	2.7	V
		$I_C = 75 \text{ A} \quad I_B = 1.5 \text{ A}$		1.5		V
		$I_C = 75 \text{ A} \quad I_B = 1.5 \text{ A} \quad T_j = 100^{\circ}\text{C}$		2.5	5	V
$V_{BE(sat)}^*$	Base-Emitter Saturation Voltage	$I_C = 50 \text{ A} \quad I_B = 1 \text{ A}$		2		V
		$I_C = 50 \text{ A} \quad I_B = 1 \text{ A} \quad T_j = 100^{\circ}\text{C}$		1.9	2.6	V
		$I_C = 75 \text{ A} \quad I_B = 1.5 \text{ A}$		2.3		V
		$I_C = 75 \text{ A} \quad I_B = 1.5 \text{ A} \quad T_j = 100^{\circ}\text{C}$		2.4	3.8	V
di_C/dt	Rate of Rise of On-state Collector	$V_{CC} = 300 \text{ V} \quad R_C = 0 \quad t_p = 3 \mu\text{s}$ $I_{B1} = 1.5 \text{ A} \quad T_j = 100^{\circ}\text{C}$	300			A/ μs
$V_{CE(3 \mu\text{s})}$	Collector-Emitter Dynamic Voltage	$V_{CC} = 300 \text{ V} \quad R_C = 4 \Omega$ $I_{B1} = 1.5 \text{ A} \quad T_j = 100^{\circ}\text{C}$		6	9	V
$V_{CE(5 \mu\text{s})}$	Collector-Emitter Dynamic Voltage	$V_{CC} = 300 \text{ V} \quad R_C = 4 \Omega$ $I_{B1} = 1.5 \text{ A} \quad T_j = 100^{\circ}\text{C}$		3.6	6	V
t_s	Storage Time	$I_C = 75 \text{ A} \quad V_{CC} = 50 \text{ V}$ $I_{B1} = 1.5 \text{ A} \quad I_{B2} = -4 \text{ A}$ $V_{clamp} = 400 \text{ V} \quad R_{BB} = 0.3 \Omega$ $L = 50 \mu\text{H} \quad T_j = 100^{\circ}\text{C}$		5	8	μs
t_f	Fall Time			0.8	1.5	μs
t_c	Cross-over Time					μs
V_{CEW}	Maximum Collector Emitter Voltage Without Snubber	$I_{Coff} = 75 \text{ A} \quad I_{B1} = 1.5 \text{ A}$ $V_{CC} = 50 \text{ V} \quad I_{B2} = -4 \text{ A}$ $L = 50 \mu\text{H} \quad R_{BB} = 0.3 \Omega$ $T_j = 125^{\circ}\text{C}$	450			V
V_F^*	Diode Forward Voltage	$I_F = 75 \text{ A} \quad T_j = 100^{\circ}\text{C}$			2	V
I_{RM}	Reverse Recovery Current	$V_{CC} = 200 \text{ V} \quad I_F = 30 \text{ A}$ $di_F/dt = 375 \text{ A}/\mu\text{s} \quad L < 50 \text{ nH}$ $T_j = 100^{\circ}\text{C}$			45	A

* Pulsed; Pulse duration = 300 μs , duty cycle 1.5 %

To evaluate the conduction losses of the diode use the following equations:

$$V_F = 0.66 + 0.0034 I_F \quad P = 0.66 I_{F(AV)} + 0.0034 I_{F(RMS)}^2$$

See test circuits in databook introduction

Safe Operating Areas

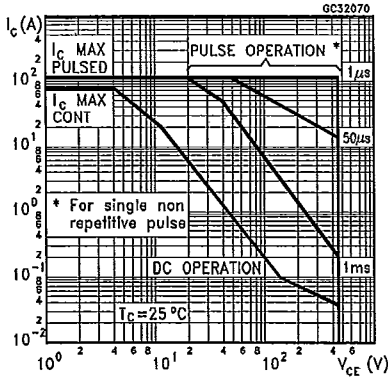

Thermal Impedance

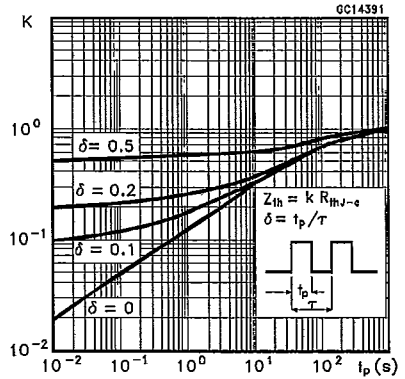

Derating Curve

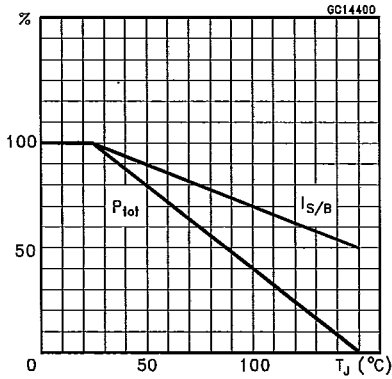

Collector-Emitter Voltage Versus Base-Emitter Resistance

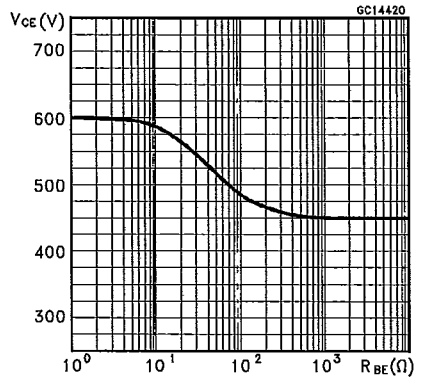

Collector-Emitter Saturation Voltage

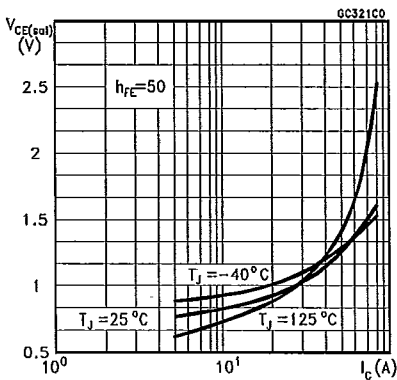

Base-Emitter Saturation Voltage

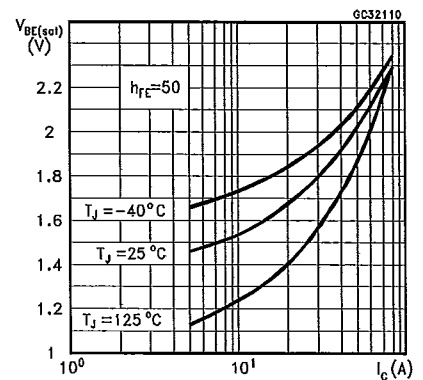

Reverse Biased SOA

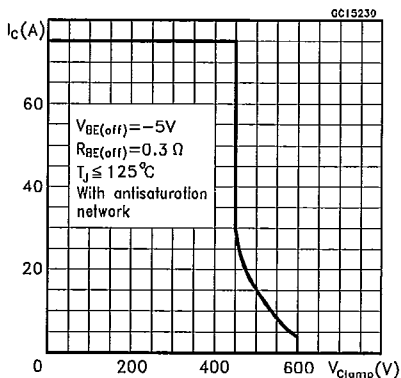

Forward Biased SOA

T-33-35

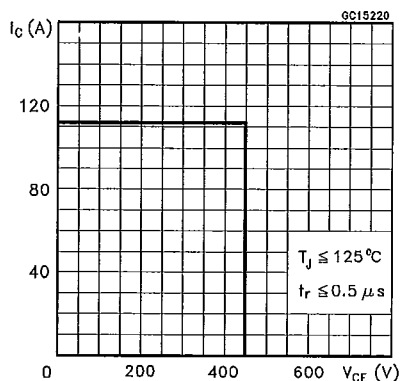

Reverse Biased AOA

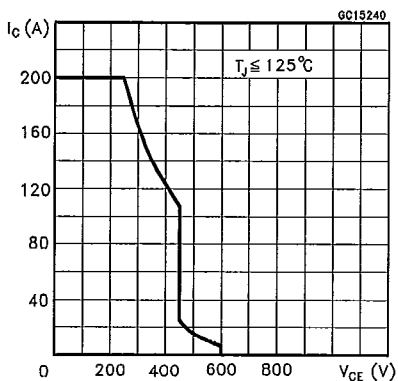

Forward Biased AOA

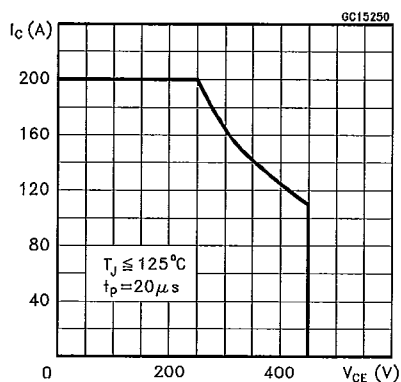

Switching Times Inductive Load

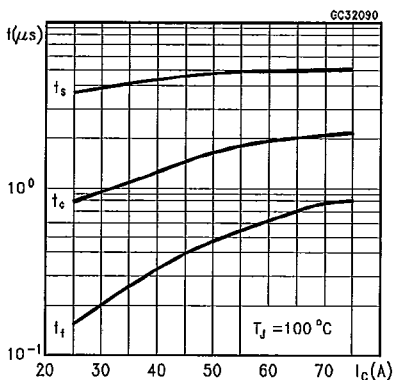

Switching Times Inductive Load Versus Temperature

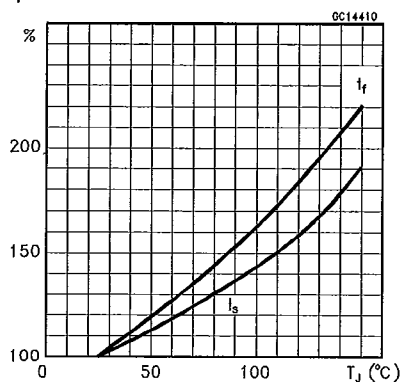

DC Current Gain

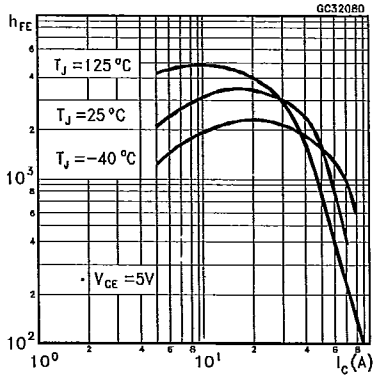

Typical V_F Versus I_F

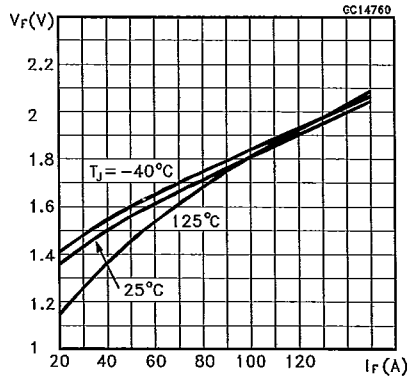

Peak Reverse Current Versus di_F/dt

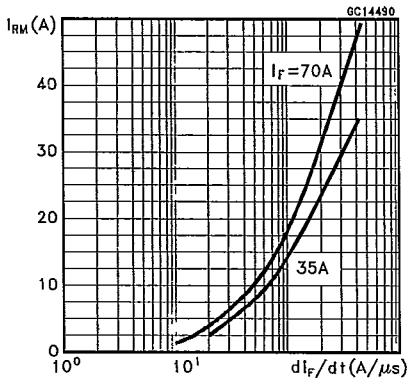

Turn-on Switching Test Circuit

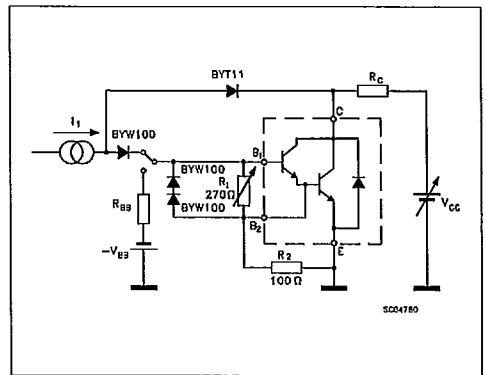

Turn-on Switching Waveforms

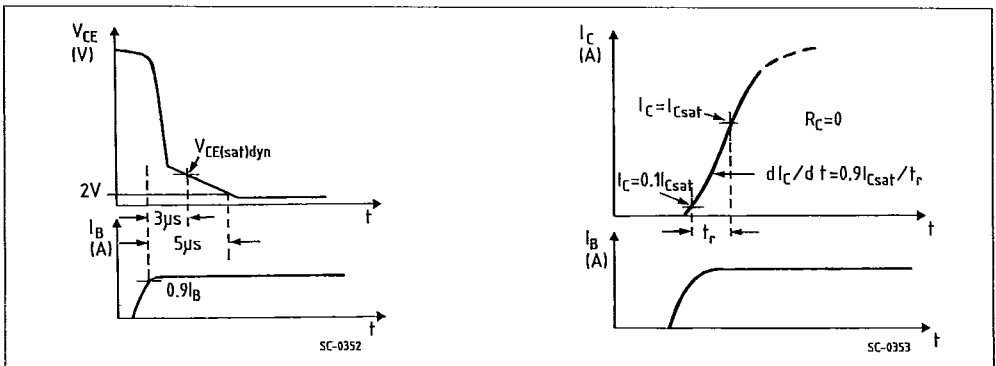

Turn-off Switching Test Circuit

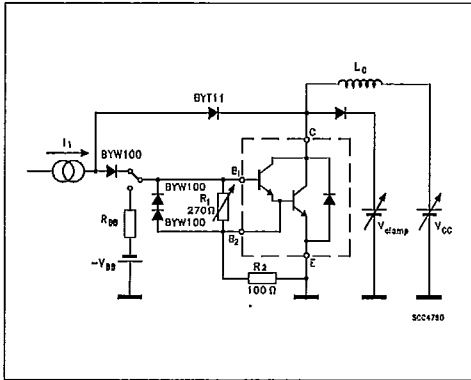

Turn-off Switching Waveforms

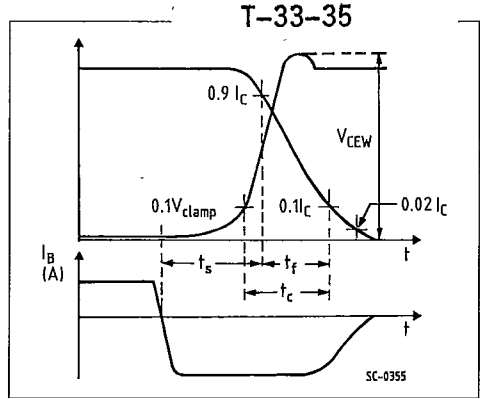

Turn-off Switching Test Circuits of Diode

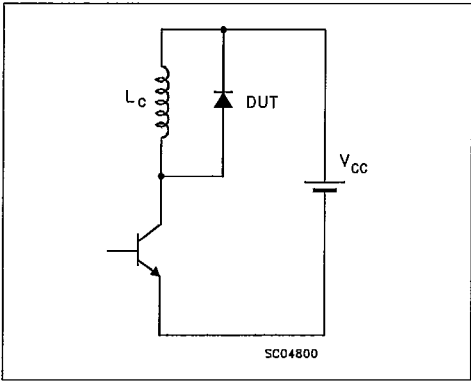

Turn-off Switching Waveform of Diode

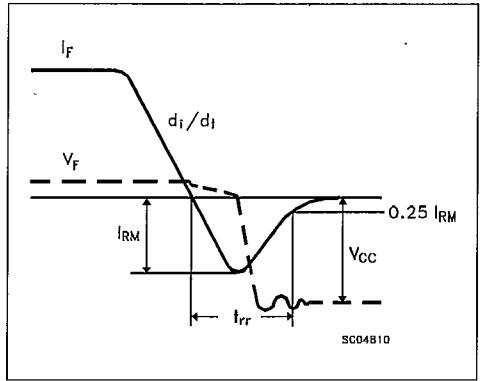

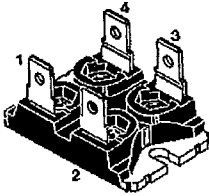

ISOTOP
Fast-on version
 sales types with the suffix F

MECHANICAL DATA

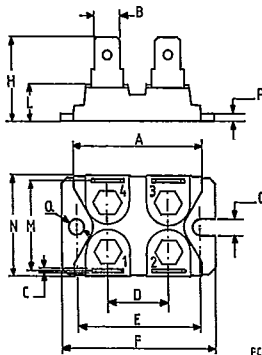

FC-9309

	DIMENSIONS			
	mm		Inches	
	min.	max	min.	max
A	31.5	31.7	1.240	1.248
B	6.2	6.4	0.244	0.252
C	0.75	0.85	0.029	0.033
D	14.9	15.1	0.586	0.590
E	30.1	30.3	1.185	1.193
F	38	38.2	1.496	1.503
G	4	-	0.157	-
H	20.3	20.7	0.799	0.815
L	8.9	9.1	0.350	0.358
M	22.4	23	0.881	0.905
N	25.2	25.4	0.992	1.000
P	1.95	2.05	0.076	0.080
Q	4	-	0.157	-

PIN CONNECTIONS

MOSFET

pin 1: Source pin 2: Gate
 pin 3: Drain pin 4: Source sensings

DARLINGTON

pin 1: Emitter pin 2: Base1
 pin 3: Collector pin 4: Base 2

TRANSISTOR

pin 1: Emitter pin 2: Base
 pin 3: Collector pin 4: Emitter sensing

Torque: Mounting $1.3 \pm 0.2 \text{ N} \cdot \text{m}$ (max)

Weight: Package 25.5 g

Note: The mechanical data are the same for the 3 pin version
 (4th pin missing)

T-91-20

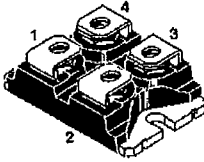

ISOTOP
Screw version
sales types with the suffix V

MECHANICAL DATA

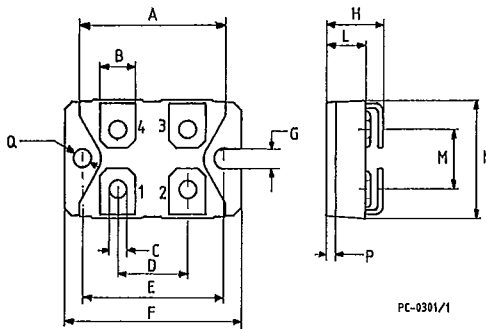

PC-0301/1

	DIMENSIONS			
	mm		Inches	
	min.	max	min.	max
A	31.5	31.7	1.240	1.248
B	7.8	8.2	0.307	0.322
C	4.1	4.3	0.161	0.169
D	14.9	15.1	0.586	0.590
E	30.1	30.3	1.185	1.193
F	38	38.2	1.496	1.503
G	4	-	0.157	-
H	11.8	12.2	0.464	0.480
L	8.9	9.1	0.350	0.358
M	12.6	12.8	0.496	0.503
N	25.2	25.4	0.992	1.000
P	1.95	2.05	0.076	0.080
Q	4	-	0.157	-

PIN CONNECTIONS

MOSFET

pin 1: Source pin 2: Gate
pin 3: Drain pin 4: Source sensings

DARLINGTON

pin 1: Emitter pin 2: Base1
pin 3: Collector pin 4: Base 2

TRANSISTOR

pin 1: Emitter pin 2: Base
pin 3: Collector pin 4: Emitter sensing

Torque: Terminal $1.3 \pm 0.2 \text{ N} \cdot \text{m}$ (max)
Mounting $1.3 \pm 0.2 \text{ N} \cdot \text{m}$ (max)

Weight: Package 29 g
4 Screws: 7.5 g

Note: The mechanical data are the same for the 3 pin version
(4th pin missing)

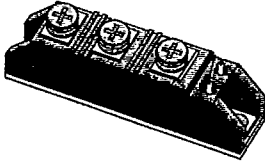

TRANSPACK (TO-240)

MECHANICAL DATA

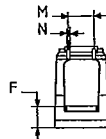
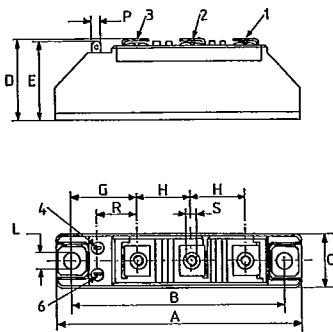

PC-0236

	DIMENSIONS			
	mm		Inches	
	min.	max	min.	max
A	91.5	92.5	3.602	3.641
B	79.75	80.25	3.140	3.160
C	19.5	20.55	0.767	0.809
D	29.00	31.00	1.141	1.220
E	28.8	30	1.134	1.181
F	8.5 typ.		0.334 typ.	
G	24.4 typ.		0.960 typ.	
H	19.5	20.5	0.767	0.807
L	6.2 typ.		0.244 typ.	
M	8.95	11.05	0.352	0.435
N	0.78	0.84	0.030	0.033
P	2.72	2.87	0.107	0.113
R	14	-	0.551	-
S	M5			

Torque: Terminal $2.2 \pm 0.5 \text{ N} \cdot \text{m}$ (max)
 Mounting $3.5 \pm 0.5 \text{ N} \cdot \text{m}$ (max)

Weight: Package 110 g
 Accessory 21 g

Note: The mechanical data are the same for the 2 power pin version (either pin 1 or pin 2 missing)