

Load A*

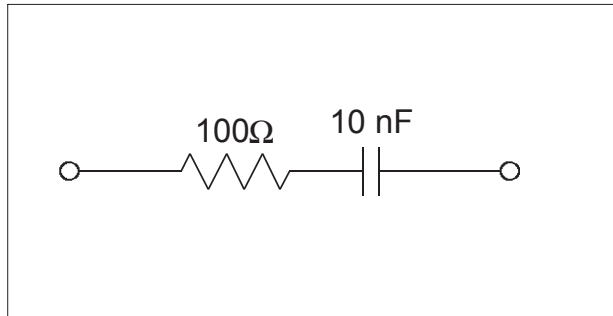

* Load A approximates a 3in² EL lamp.

Sample Output Waveform

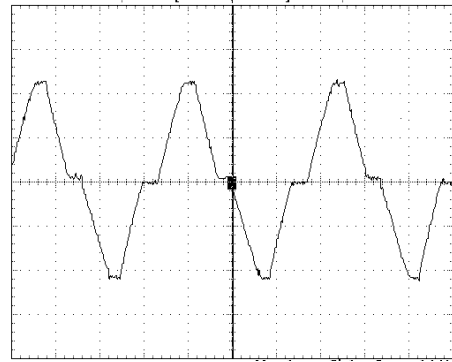

Absolute Maximum Ratings:

| Parameter | Symbol | Minimum | Maximum | Unit | Comments |
|-----------------------|----------------|---------|----------|------|----------|
| Supply voltage | | | | | |
| Operating range | V+ | 2.0 | 6.5 | V | E = V+ |
| Withstand range | | -0.5 | 9.0 | | E = GND |
| Enable Voltage | E | -0.5 | (V+)+0.5 | V | |
| Lamp Output | Vout | | 220 | Vpp | E = V+ |
| Operating temperature | T _a | -40 | 85 | °C | |
| Storage temperature | T _s | -65 | 150 | °C | |

Note: The above are stress ratings only. Functional operation of the device at these ratings or any other above those indicated in the specifications is not implied. Exposure to absolute maximum rating conditions for extended periods of time may affect reliability.

Physical Data:

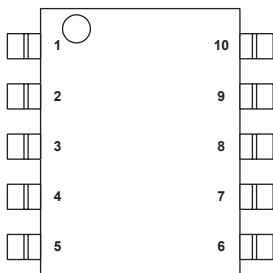

| PIN # | NAME | FUNCTION |
|-------|------|--|
| 1 | V+ | DC power supply input |
| 2 | CLF | Low frequency oscillator capacitor/LF clock input |
| 3 | CHF | High frequency oscillator capacitor/HF clock input |
| 4 | E | System enable: HI = On |
| 5 | GND | System ground connection |
| 6 | L+ | Charge pumping inductor input |
| 7 | Cs | High voltage storage capacitor |
| 8 | EL1 | AC output to lamp |
| 9 | EL2 | AC output to lamp |
| 10 | Rd | Wave shaping resistor |

Typical Performance Characteristics Using Standard Test Circuit

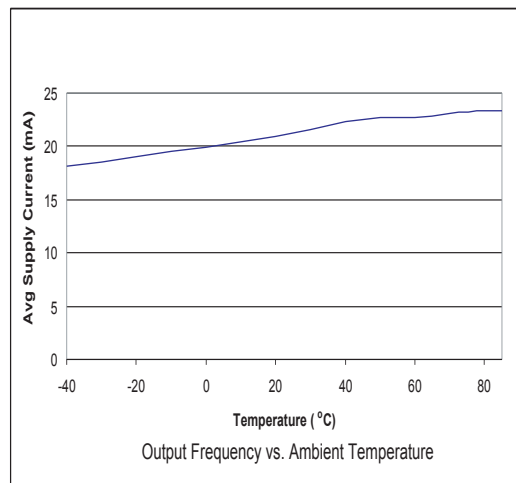
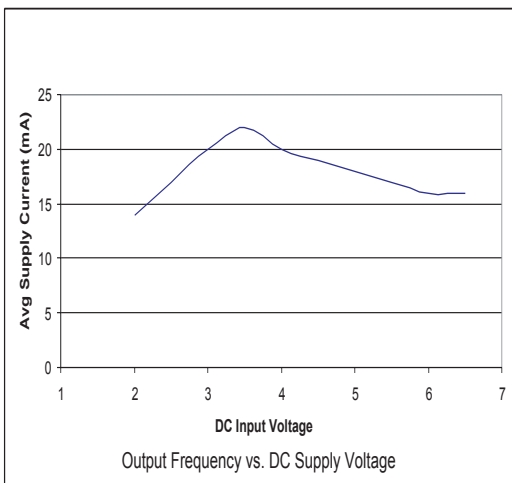
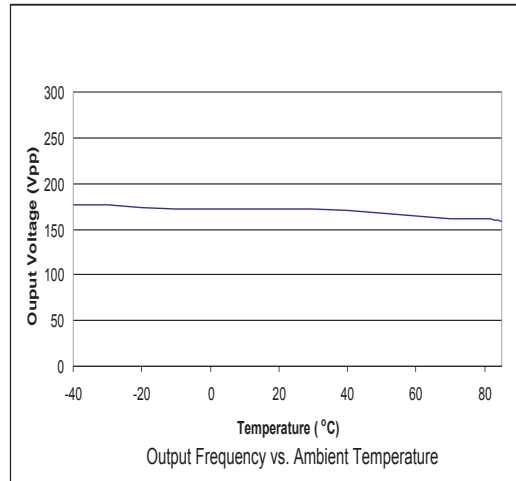
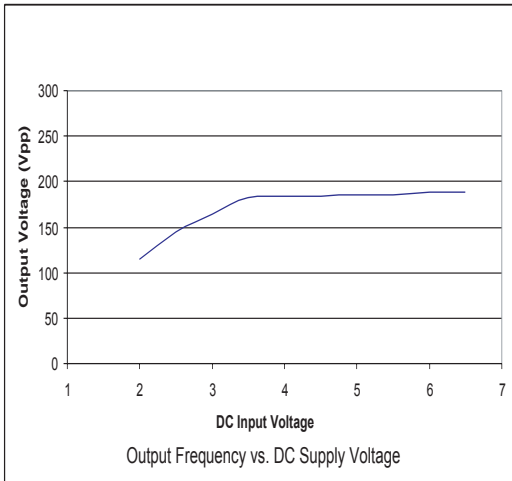
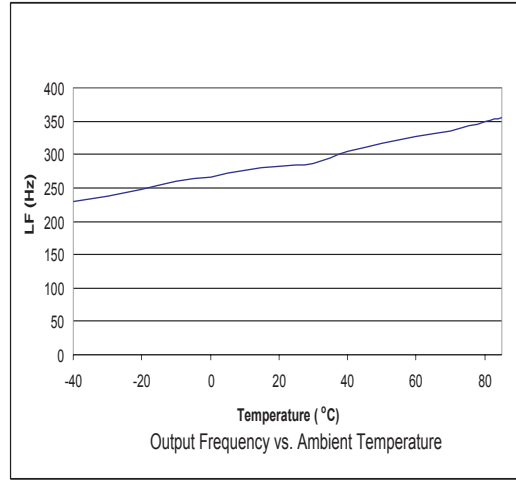
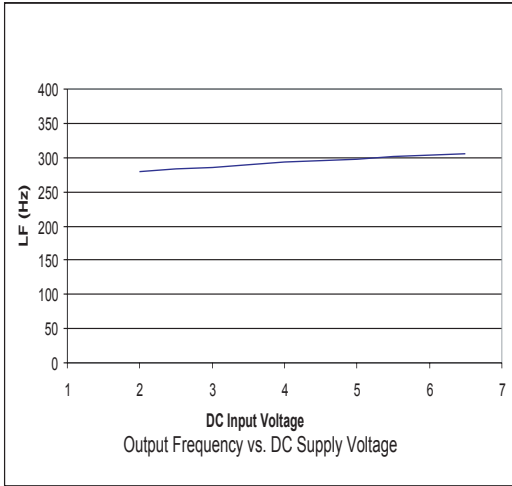

Block Diagram of the Driver Circuitry

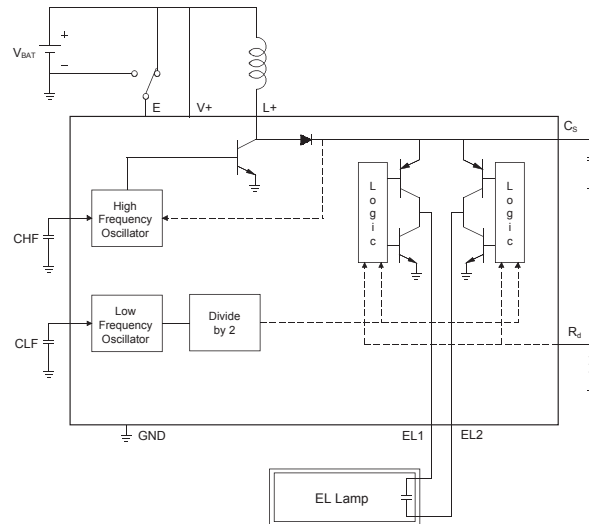

Theory of Operation

Electroluminescent (EL) lamps are essentially capacitors with one transparent electrode and a special phosphor material in the dielectric. When a strong AC voltage is applied across the EL lamp electrodes, the phosphor glows. The required AC voltage is typically not present in most systems and must be generated from a low voltage DC source.

The D372 chip inverter drives the EL lamp by using a switching BJT to repeatedly charge an external inductor and discharge it to the high voltage capacitor C_s . The discharging causes the voltage at C_s to continually increase. When the voltage at C_s reaches a nominal value, the switching BJT is turned off. The internal circuitry uses the H-bridge technology, using both electrodes to drive the EL lamp. One of the outputs, EL1 or EL2, is used to discharge C_s into the EL lamp during the first half of the low frequency (LF) cycle. By alternating the state of the H-bridge, the other output is used to charge the EL lamp during the second half of the LF cycle. The alternating states make it possible to achieve 200V peak-to-peak across the EL lamp.

The EL driving system is divided into several parts: on-chip logic control, on-chip high voltage output circuitry, on-chip discharge logic circuitry, and off-chip components. The on-chip logic controls the lamp operating frequency (LF) and the inductor switching frequency (HF). These signals are used to drive the high voltage output circuitry (H-bridge) by delivering the power from the inductor to the lamp. The integrated discharge logic circuitry uses a patented wave shaping technique for reducing audible noise from an EL lamp. Changing the R_d value changes the slope of the linear discharge as well as the shape of the waveform. The off-chip component selection provides a degree of flexibility to accommodate various lamp sizes, system voltages, and brightness levels.

Typical D372 EL driving configurations for driving EL lamps in various applications are shown on the following page. The expected system outputs for the various circuit configurations are also shown with each respective figure. These examples are only guides for configuring the driver. Durel provides a D372 Designer's Kit, which includes a printed circuit evaluation board intended to aid you in developing an EL lamp driver configuration using the D372 that meets your requirements. A section on designing with the D372 is included in this datasheet to serve as a guide to help you select the appropriate external components to complete your D372 EL driver system.

Typical D372A EL Driver Configurations

3.0V Handset LCD

Typical Output

Brightness = 6.0 fL (20.6 cd/m²)
 Lamp Frequency = 285 Hz
 Supply Current = 12 mA
 Vout = 208 Vpp
 Load = 1 in² (645 mm²) Durel[®] 3
 Green EL

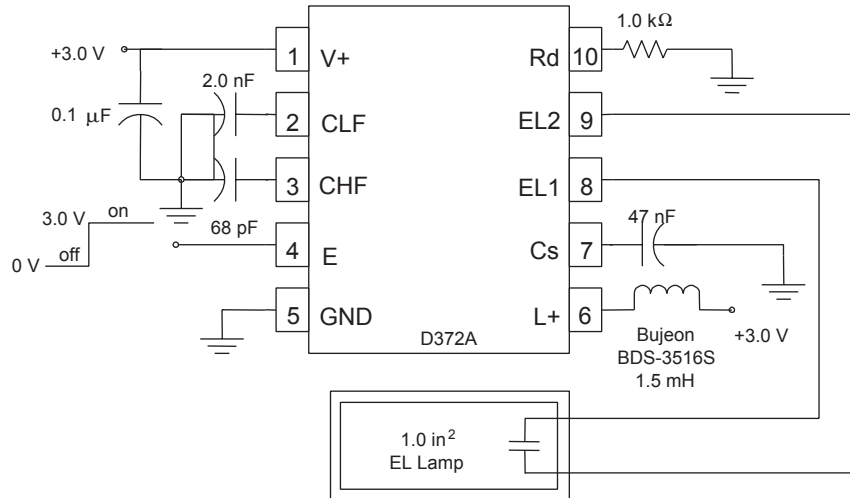

3.3V Handset LCD and Keypad

Typical Output

Luminance = 5.5 fL (18.8 cd/m²)
 Lamp Frequency = 290 Hz
 Supply Current = 17 mA
 Vout = 200 Vpp
 Load = 1.5 in² (950 mm²) Durel[®] 3
 Green EL

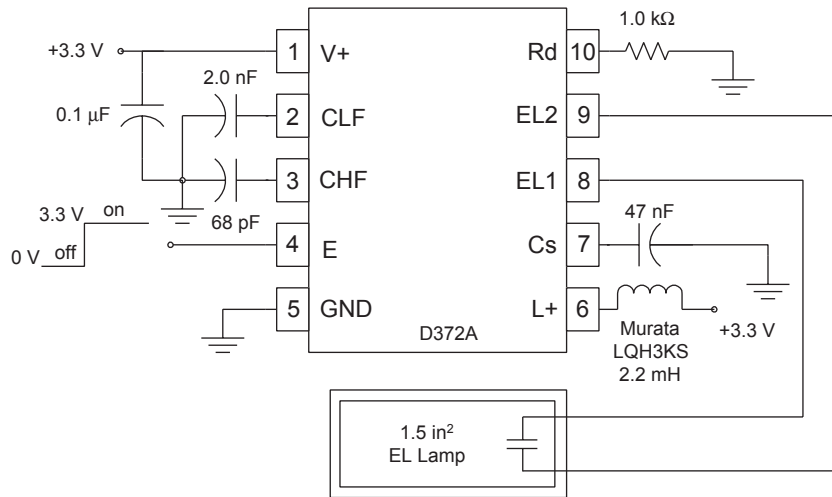

5.0V LCD Backlight

Typical Output

Luminance = 6.0 fL (24.3 cd/m²)
 Lamp Frequency = 300 Hz
 Supply Current = 22 mA
 Vout = 206 Vpp
 Load = 4 in² (2580 mm²) Durel[®] 3
 Green EL

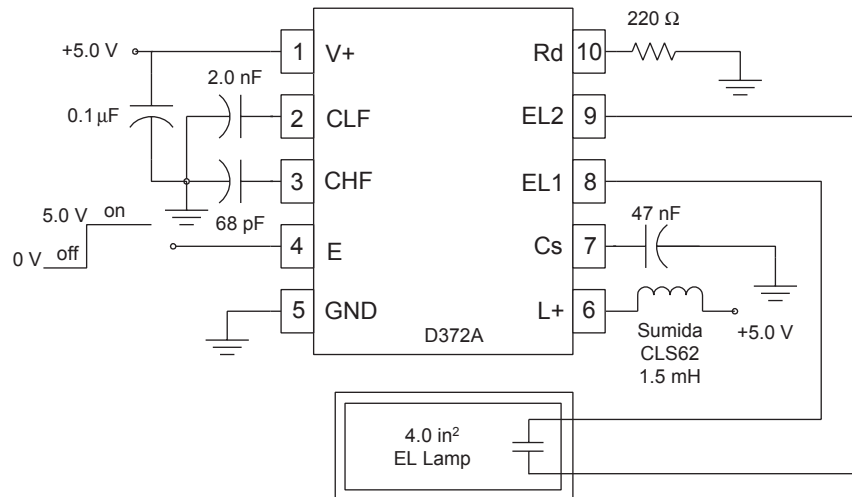

Designing With D372

I. Lamp Frequency Capacitor (CLF) Selection

Selecting the appropriate value of capacitor (CLF) for the low frequency oscillator will set the output frequency of the D372 inverter. Figure 1 graphically represents the effect of the CLF capacitor value on the oscillator frequency at $V+=3.0V$.

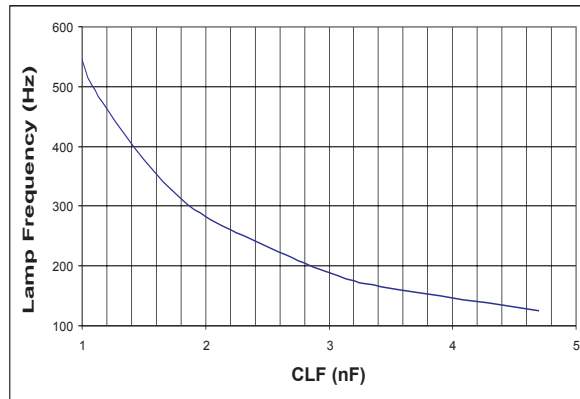

Figure 1: Typical Lamp Frequency vs. CLF Capacitor

The lamp frequency may also be controlled with an external clock signal. The resulting lamp frequency will be half of the clock signal frequency. The differential output voltage will increase in magnitude during the high portion of the clock signal and decrease during the low portion of the clock signal. Lamp frequencies of 200-500Hz are typically used.

The selection of the CLF value can also affect the output brightness and current consumption of the driver. The EL lamp frequency (LF) depends on lamp size, drive conditions, and mainly on the CLF value selected. Figures 2 and 3 show typical brightness and current draw of a D372 circuit at different frequencies. The data was taken with an average 1.0mH inductor and 68 pf CHF capacitor.

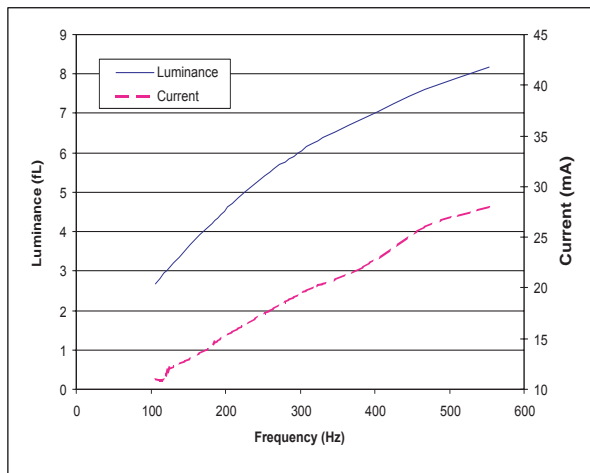

Figure 2: Typical Luminance and Current vs. Lamp Frequency
Conditions: $V+=3.0V$, 1.5 in² EL Lamp

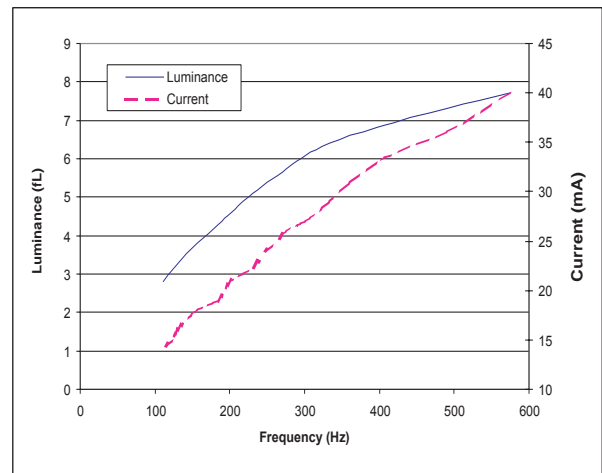

Figure 3: Typical Luminance and Current vs. Lamp Frequency
Conditions: $V+=5.0V$, 4.0 in² EL Lamp

II. Inductor Switching Frequency (CHF) Selection

Selecting the appropriate value of capacitor (CHF) for the high frequency oscillator will set the inductor switching frequency of the D372 inverter. Figure 4 graphically represents the effect of the CHF capacitor value on the oscillator frequency at $V+ = 3.0V$.

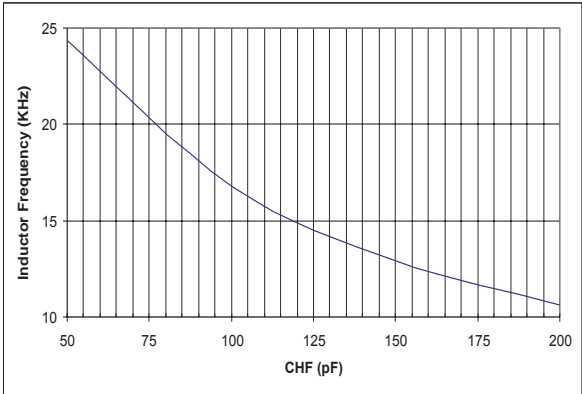

Figure 4: Typical Inductor Frequency vs. CHF Capacitor

The inductor switching frequency may also be controlled with an external clock signal. The inductor will charge during the low portion of the clock signal and discharge into the EL lamp during the high portion of the clock signal.

III. Inductor (L) Selection

The inductor value and inductor switching frequency have the greatest impact on the output brightness and current consumption of the driver. Figures 5 and 6 show typical brightness and current draw of a D372 circuit with several different inductor and CHF values. The CLF value was modified in each case such that the output voltage was approximately 200Vpp. The data was taken with average inductors. Please note that the DC resistance (DCR) and current rating of inductors with the same inductance value may vary with manufacturer and inductor type. Thus, inductors made by a different manufacturer may yield different outputs, but the trend of the different curves should be similar.

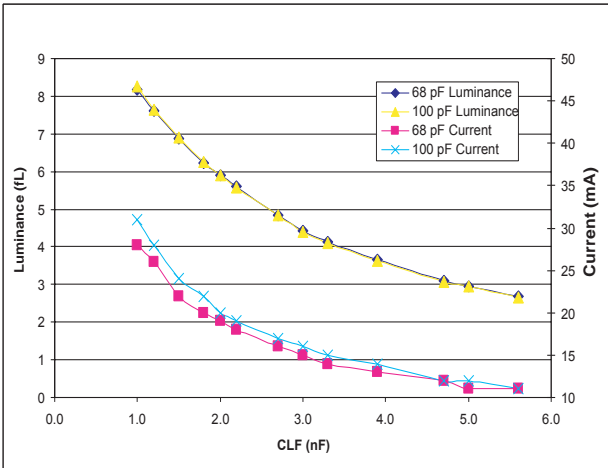

Figure 5: Luminance and Current vs. Inductor and CHF Value
Conditions: $V+ = 3.0 V$, 1.5 in^2 EL Lamp

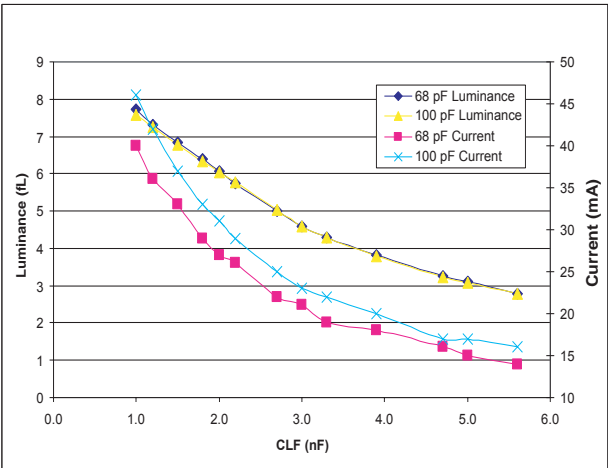

Figure 6: Luminance and Current vs. Inductor and CHF value
Conditions: $V+ = 5.0 V$, 4 in^2 EL Lamp

IV. Wave-Shape (Rd) Selection

The R_d resistor determines the slope of the charge and discharge portions of the output waveform. The optimal value of this resistor depends on the lamp size and drive conditions. Typical values range from 0Ω - $2.0k\Omega$. Recommended starting values for various lamp sizes are shown in the table below. The optimal waveform is trapezoidal which will result in the best combination of high brightness and low audible noise performance. Using a larger value of R_d than recommended will result in a triangular waveform and correspond to reducing the audible noise of the EL lamp and increase lamp life. However, the luminance of the EL lamp will decrease. Using a smaller value of R_d than recommended will result in a square waveform and correspond to higher initial luminance from the EL lamp, but will not take advantage of the noise reduction capability of the D372.

| Rd | Lamp Size |
|---------------|-------------------------|
| 1.2k Ω | <1.0 in ² |
| 820 Ω | 1.0-2.0 in ² |
| 470 Ω | 2.0-4.0 in ² |
| 220 Ω | >4.0 in ² |

Typical waveforms corresponding to the selected R_d values for a 2in² lamp and a 4in² lamp are shown below.

Lamp Size 2 in²

Rd=820 Ω

Optimal waveform for 2 in²

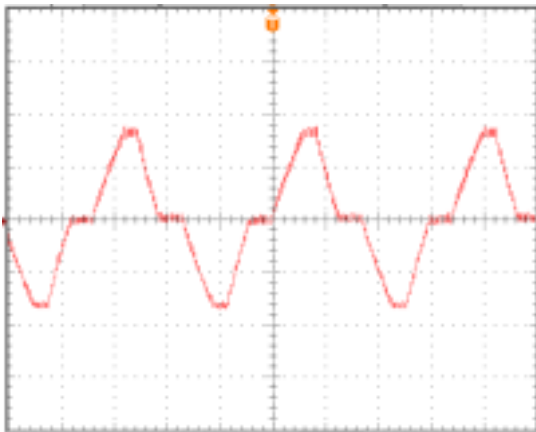

Rd=1.2k Ω

Reduced noise with lower luminance

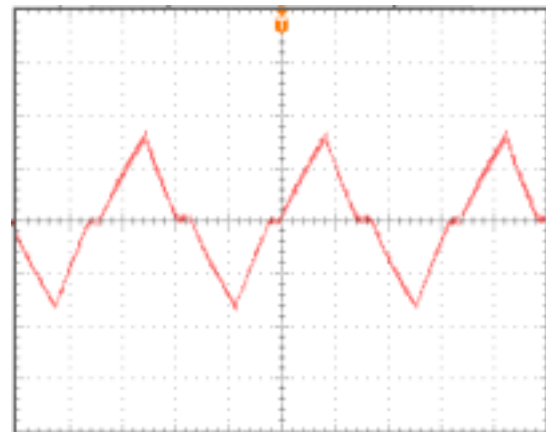

Lamp Size 4 in²

Rd=470 Ω

Optimal waveform for 4 in²

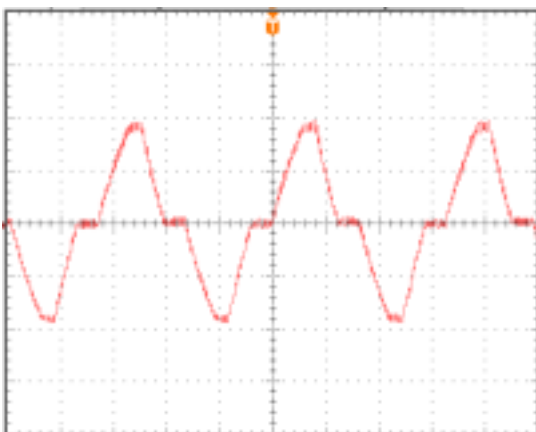

Rd=0 Ω

Higher luminance with more noise

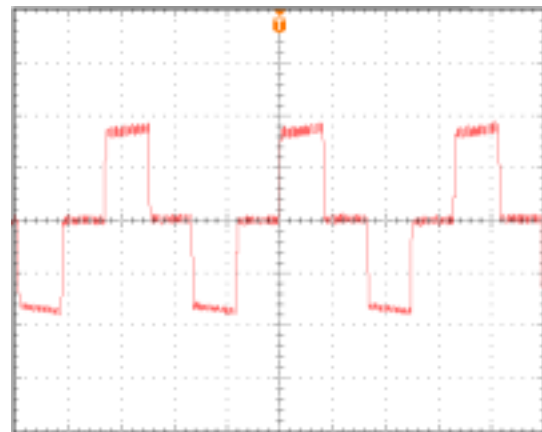

V. Storage Capacitor (C_s) Selection

The C_s capacitor is used to store the energy transferred from the inductor. Capacitors with larger values have a larger time constant and will store the energy for longer periods of time. The recommended C_s values range from 10nF to 47nF and are to be rated to at least 100V. Larger EL lamps typically require larger values of C_s . In general, increasing the value of C_s will increase the RMS voltage and increase the brightness of an EL lamp. Typical waveforms for varying C_s values for a 2.0 in² lamp are shown below.

$C_s=10\text{nF}$

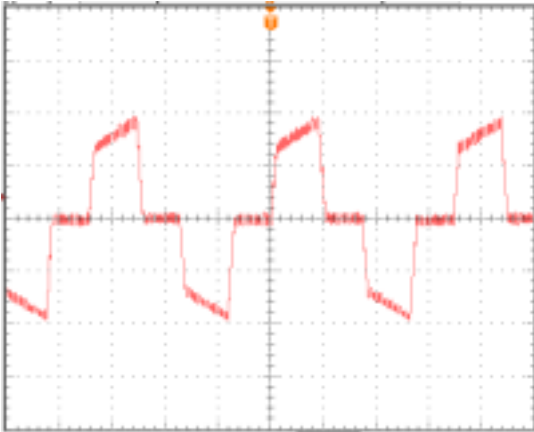

$C_s=22\text{nF}$

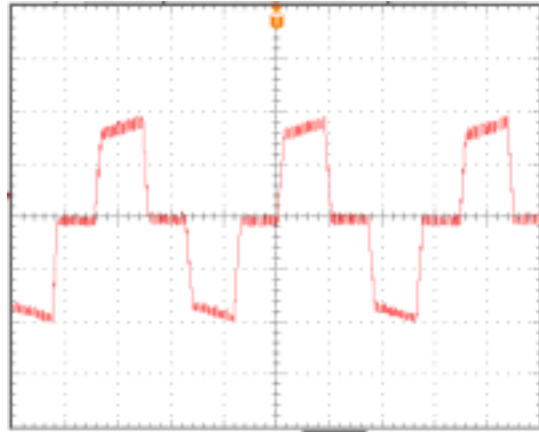

$C_s=47\text{nF}$

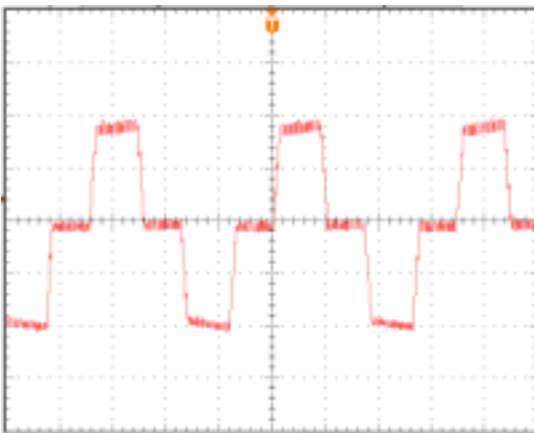

D372 Design Ideas

I. Lamp Frequency Control With an External Clock Signal

An external clock signal may be used to control the EL lamp frequency (LF) by applying the clock signal to the CLF pin. The oscillator frequency can be varied to synchronize the inverter with other elements in the application. An internal divider network in the IC divides the clock signal by two. The recommended clocking frequencies range from 500Hz to 1kHz and result in an EL lamp frequency range of 250Hz to 500Hz respectively. The amplitude of the clock signal typically ranges from 1.0V to V+.

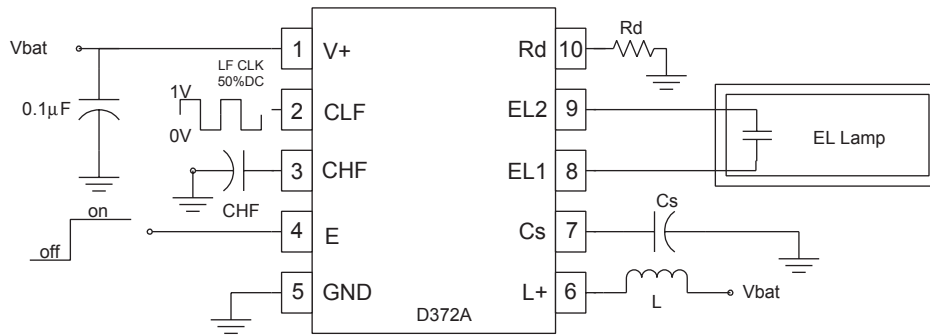

II. Controlling EL Brightness Through Clock Pulse Width Modulation

An external clock signal may be used to control the inductor oscillating frequency (HF). Pulse width modulation of the external clock signal may be used to regulate the brightness of an EL lamp. In this circuit, when the positive duty cycle of the external clock is at 20%, the lamp is at full brightness. Incremental dimming occurs as the positive duty cycle is increased to as high as 85%. This scheme may also be used inversely to regulate lamp brightness over the life of the battery or to compensate for lamp aging. (Note: Operation at duty cycles higher than 85% and lower than 20% is not recommended.) The recommended clocking frequency ranges from 10kHz to 24kHz, and the amplitude of the clock signal typically ranges from 1.0V to V+.

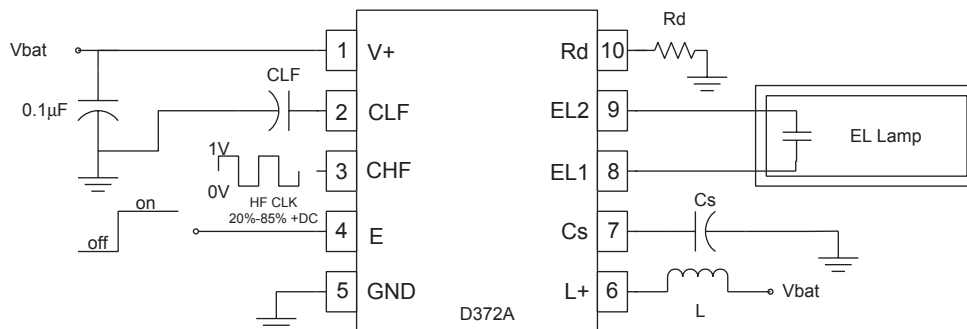

III. Split Voltage Supply

A split supply voltage may also be used to drive the D372. To operate the on-chip logic, a regulated voltage supply ($V+$) ranging from 2.0V to 6.5V is applied. To supply the D372 with the necessary power to drive an EL lamp, another supply voltage (V_{bat}) is applied to the inductor. The voltage range of V_{bat} is determined by the following conditions: driver application, lamp size, inductor selection, and voltage and current limitations.

Two different examples of the split supply are shown below. The first example shows a regulated 3.0V applied to the $V+$ pin, and a V_{bat} voltage that may range from 2.7V to 4.5V. The enable voltage is in the range of 2.0V to 3.0V. This is a typical setup used in cell phone applications.

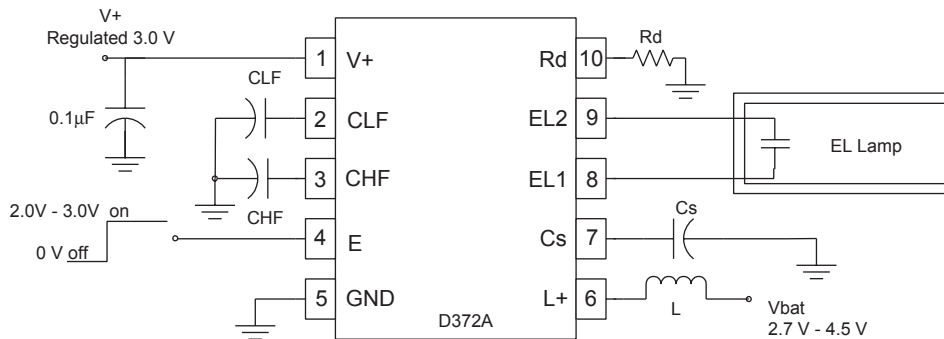

The second example shows that $V+$ may range from 2.0V to 6.5V, and the V_{bat} voltage may be as high as 12.0V. The enable voltage is in the range of 2.0V to $V+$. This is useful in many high voltage applications.

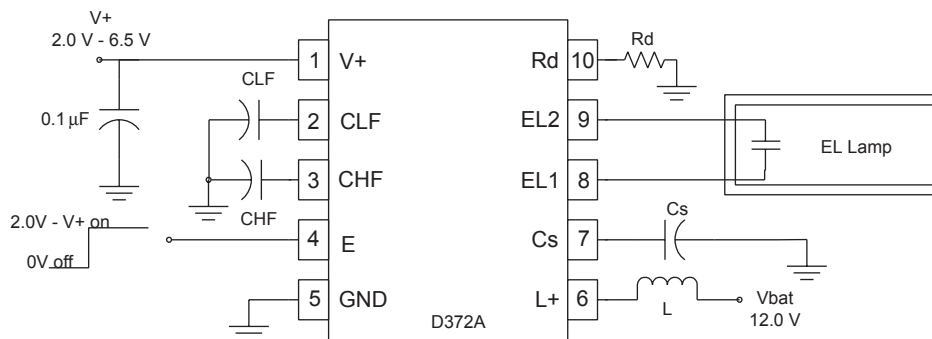

Ordering Information

The D372A IC is available in standard MSOP-10 plastic package per tape and reel. A Durel D372 Designer's Kit (1DDD372AA-K01) provides a vehicle for evaluating and identifying the optimum component values for any particular application using D372. Durel engineers also provide full support to customers including specialized circuit optimization and application retrofits.

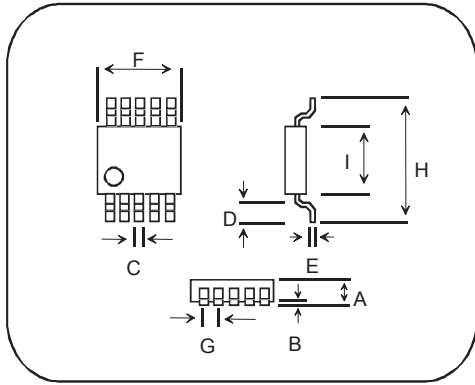

| | MSOP-10 | | | | | |
|---|---------|-------|---------|-------|------|-------|
| | Min. | | Typical | | Max. | |
| | mm. | in. | mm. | in. | mm. | in. |
| A | 0.92 | 0.036 | 1.00 | 0.039 | 1.08 | 0.043 |
| B | 0.05 | 0.002 | 0.10 | 0.004 | 0.15 | 0.006 |
| C | 0.15 | 0.006 | 0.23 | 0.009 | 0.31 | 0.012 |
| D | 0.40 | 0.016 | 0.55 | 0.022 | 0.70 | 0.028 |
| E | 0.13 | 0.005 | 0.18 | 0.007 | 0.23 | 0.009 |
| F | 2.90 | 0.114 | 3.00 | 0.118 | 3.10 | 0.122 |
| G | 0.35 | 0.014 | 0.50 | 0.020 | 0.65 | 0.026 |
| H | 4.75 | 0.187 | 4.90 | 0.193 | 5.05 | 0.199 |
| I | 2.90 | 0.114 | 3.00 | 0.118 | 3.10 | 0.122 |

MSOPs are marked with part number (372A) and 3-digit wafer lot code. Bottom of marking is on the Pin 1 side.

RECOMMENDED PAD LAYOUT

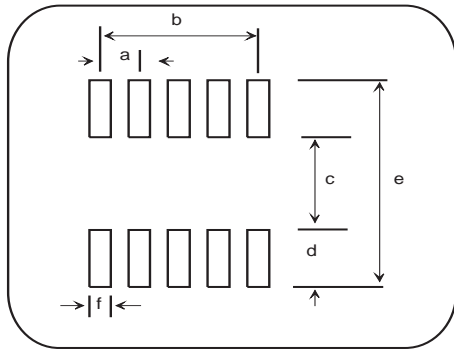

| | MSOP-10 PAD LAYOUT | | | | | |
|---|--------------------|-------|---------|--------|------|-------|
| | Min. | | Typical | | Max. | |
| | mm. | in. | mm. | in. | mm. | in. |
| a | | | 0.5 | 0.0197 | | |
| b | | | 2.0 | 0.0788 | | |
| c | 3.3 | 0.130 | | | 3.45 | 0.136 |
| d | 0.89 | 0.035 | 0.97 | 0.038 | 1.05 | 0.041 |
| e | 5.26 | 0.207 | | | 5.41 | 0.213 |
| f | | | 0.3 | 0.012 | | |

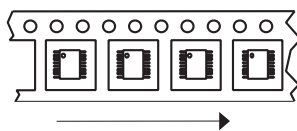

Tape Orientation

MSOPs in Tape and Reel:

1DDD372AA-M04

Embossed tape on 360 mm diameter reel per EIA-481-2.
2500 units per reel. Quantity marked on reel label.

ISO 9001 Certified

DUREL Corporation

2225 W. Chandler Blvd.

Chandler, AZ 85224-6155

Tel: (480) 917-6000

FAX: (480) 917-6049

Website: <http://www.durel.com>

The DUREL name and logo are registered trademarks of DUREL CORPORATION.

This information is not intended to and does not create any warranties, express or implied, including any warranty of merchantability or fitness for a particular purpose. The relative merits of materials for a specific application should be determined by your evaluation.

This driver is covered by the following U.S. patents: #5,313,141, #5,789,870; #6,297,597 B1. Corresponding foreign patents are issued and pending.