

MC100LVELT23

3.3 V Dual Differential LVPECL/LVDS to LVTTTL Translator

Description

The MC100LVELT23 is a dual differential LVPECL/LVDS to LVTTTL translator. Because LVPECL (Positive ECL) or LVDS levels are used only +3.3 V and ground are required. The small outline 8-lead package and the dual gate design of the LVELT23 makes it ideal for applications which require the translation of a clock and a data signal.

The LVELT23 is available in only the ECL 100K standard. Since there are no LVPECL outputs or an external V_{BB} reference, the LVELT23 does not require both ECL standard versions. The LVPECL inputs are differential. Therefore, the MC100LVELT23 can accept any standard differential LVPECL input referenced from a V_{CC} of +3.3 V.

Features

- 2.0 ns Typical Propagation Delay
- Maximum Frequency > 180 MHz
- Differential LVPECL Inputs
- PECL Mode Operating Range: $V_{CC} = 3.0\text{ V to }3.8\text{ V}$ with $GND = 0\text{ V}$
- 24 mA LVTTTL Outputs
- Flow Through Pinouts
- Internal Pulldown and Pullup Resistors
- Pb-Free Packages are Available



ON Semiconductor®

<http://onsemi.com>

MARKING DIAGRAMS*



SOIC-8
D SUFFIX
CASE 751

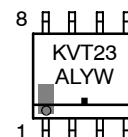

TSSOP-8
DT SUFFIX
CASE 948R

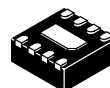
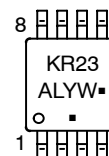

DFN8
MN SUFFIX
CASE 506AA

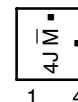

A = Assembly Location
L = Wafer Lot
Y = Year
W = Work Week
 \overline{M} = Date Code
▪ = Pb-Free Package

(Note: Microdot may be in either location)

*For additional marking information, refer to Application Note AND8002/D.

ORDERING INFORMATION

See detailed ordering and shipping information in the package dimensions section on page 5 of this data sheet.

MC100LVELT23

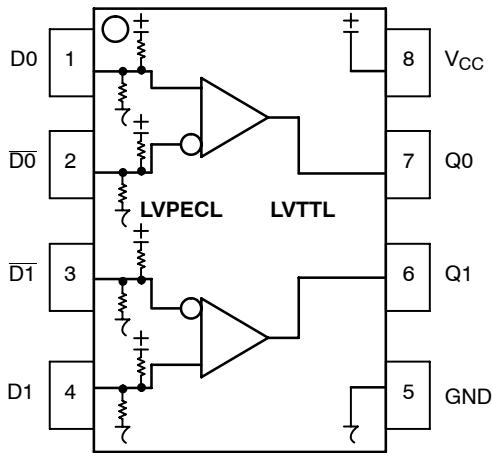

Figure 1. 8-Lead Pinout (Top View) and Logic Diagram

Table 1. PIN DESCRIPTION

Pin	Function
Q0, Q1 D0*, D1* D0-bar*, D1-bar*	LVTTTL Outputs Differential LVPECL Inputs
VCC GND EP	Positive Supply Ground Exposed pad must be connected to a sufficient thermal conduit. Electrically connect to the most negative supply or leave floating open.

** Pins will default to $V_{CC}/2$ when left open.

Table 2. ATTRIBUTES

Characteristics	Value
Internal Input Pulldown Resistor	50 k Ω
Internal Input Pullup Resistor	50 k Ω
ESD Protection	Human Body Model Machine Model CDM
	> 1500 V > 100 V > 2000 V
Moisture Sensitivity, Indefinite Time Out of Drypack (Note 1)	Level 1
Flammability Rating	Oxygen Index: 28 to 34 UL 94 V-0 @ 0.125 in
Transistor Count	91
Meets or Exceeds JEDEC Spec EIA/JESD78 IC Latchup Test	

1. Refer to Application Note AND8003/D for additional information.

MC100LVELT23

Table 3. MAXIMUM RATINGS

Symbol	Parameter	Condition 1	Condition 2	Rating	Unit
V _{CC}	PECL Power Supply	GND = 0 V		3.8	V
V _I	Input Voltage	GND = 0 V, V _I not more positive than V _{CC}		3.8	V
I _{out}	Output Current	Continuous Surge		50 100	mA
T _A	Operating Temperature Range			-40 to +85	°C
T _{stg}	Storage Temperature			-65 to +150	°C
θ _{JA}	Thermal Resistance (Junction-to-Ambient)	0 lfm 500 lfm	SOIC-8 SOIC-8	190 130	°C/W °C/W
θ _{JC}	Thermal Resistance (Junction-to-Case)	Standard Board	SOIC-8	41 to 44 ± 5%	°C/W
θ _{JA}	Thermal Resistance (Junction-to-Ambient)	0 lfm 500 lfm	TSSOP-8 TSSOP-8	185 140	°C/W °C/W
θ _{JC}	Thermal Resistance (Junction-to-Case)	Standard Board	TSSOP-8	41 to 44 ± 5%	°C/W
θ _{JA}	Thermal Resistance (Junction-to-Ambient)	0 lfm 500 lfm	DFN8 DFN8	129 84	°C/W °C/W
T _{sol}	Wave Solder	Pb Pb-Free		<2 to 3 sec @ 248°C <2 to 3 sec @ 260°C	°C

Stresses exceeding Maximum Ratings may damage the device. Maximum Ratings are stress ratings only. Functional operation above the Recommended Operating Conditions is not implied. Extended exposure to stresses above the Recommended Operating Conditions may affect device reliability.

Table 4. LVPECL INPUT DC CHARACTERISTICS V_{CC} = 3.3 V; GND = 0 V (Note 2)

Symbol	Characteristic	-40°C			25°C			85°C			Unit
		Min	Typ	Max	Min	Typ	Max	Min	Typ	Max	
I _{CCH}	Power Supply Current (Outputs set to HIGH)	10	18	25	10	18	25	10	18	25	mA
I _{CCL}	Power Supply Current (Outputs set to LOW)	15	26	36	15	26	36	15	26	36	mA
V _{IH}	Input HIGH Voltage (Note 4)	2135		2420	2135		2420	2135		2420	mV
V _{IL}	Input LOW Voltage (Note 4)	1490		1825	1490		1825	1490		1825	mV
V _{IHCMR}	Input HIGH Voltage Common Mode Range (Notes 3 and 4)	1.2		V _{CC}	1.2		V _{CC}	1.2		V _{CC}	V
I _{IH}	Input HIGH Current			150			150			150	μA
I _{IL}	Input LOW Current	\bar{D}	-150		-150			-150			μA

NOTE: Device will meet the specifications after thermal equilibrium has been established when mounted in a test socket or printed circuit board with maintained transverse airflow greater than 500 lfm. Electrical parameters are guaranteed only over the declared operating temperature range. Functional operation of the device exceeding these conditions is not implied. Device specification limit values are applied individually under normal operating conditions and not valid simultaneously.

- All values vary 1:1 with V_{CC}. V_{CC} can vary ±0.3 V.
- V_{IHCMR} min varies 1:1 with GND, max varies 1:1 with V_{CC}.
- LVTTTL output R_L = 500 Ω to GND.

MC100LVELT23

Table 5. LVTTTL OUTPUT DC CHARACTERISTICS $V_{CC} = 3.3\text{ V}$; $GND = 0\text{ V}$ (Note 5)

Symbol	Characteristic	-40°C			25°C			85°C			Unit
		Min	Typ	Max	Min	Typ	Max	Min	Typ	Max	
V_{OH}	Output HIGH Voltage ($I_{OH} = -3.0\text{ mA}$) (Note 6)	2.4			2.4			2.4			V
V_{OL}	Output LOW Voltage ($I_{OL} = 24\text{ mA}$) (Note 6)			0.5			0.5			0.5	V
I_{OS}	Output Short Circuit Current	-180		-50	-180		-50	-180		-50	mA

NOTE: Device will meet the specifications after thermal equilibrium has been established when mounted in a test socket or printed circuit board with maintained transverse airflow greater than 500 lfm. Electrical parameters are guaranteed only over the declared operating temperature range. Functional operation of the device exceeding these conditions is not implied. Device specification limit values are applied individually under normal operating conditions and not valid simultaneously.

5. All values vary 1:1 with V_{CC} . V_{CC} can vary $\pm 0.3\text{ V}$.
6. LVTTTL output $R_L = 500\ \Omega$ to GND.

Table 6. AC CHARACTERISTICS $V_{CC} = 3.3\text{ V}$; $GND = 0\text{ V}$ (Notes 7, 8)

Symbol	Characteristic	-40°C			25°C			85°C			Unit
		Min	Typ	Max	Min	Typ	Max	Min	Typ	Max	
F_{max}	Maximum Toggle Frequency (Note 9)	180			180			180			MHz
t_{PLH} , t_{PHL}	Propagation Delay to Output Differential	1.0	1.5	2.5	1.0	1.7	2.5	1.0	1.7	2.5	ns
t_{SK++} t_{SK--} t_{SKPP}	Output-to-Output Skew++ Output-to-Output Skew-- Part-to-Part Skew (Note 10)		15 35 70	60 80 500		15 40 70	70 80 500		30 40 140	125 80 500	ps
t_{JITTER}	Random Clock Jitter (RMS)		4.0	10		4.0	10		4.0	10	ps
V_{PP}	Input Voltage Swing (Differential Configuration) (Note 11)	200	800	1000	200	800	1000	200	800	1000	mV
t_r t_f	Output Rise/Fall Times (0.8 V – 2.0 V) Q, \bar{Q}	330	600	900	330	600	900	330	650	900	ps

NOTE: Device will meet the specifications after thermal equilibrium has been established when mounted in a test socket or printed circuit board with maintained transverse airflow greater than 500 lfm. Electrical parameters are guaranteed only over the declared operating temperature range. Functional operation of the device exceeding these conditions is not implied. Device specification limit values are applied individually under normal operating conditions and not valid simultaneously.

7. All values vary 1:1 with V_{CC} . V_{CC} can vary $\pm 0.3\text{ V}$.
8. LVTTTL output $R_L = 500\ \Omega$ to GND and $C_L = 20\text{ pF}$ to GND. Refer to Figure 2.
9. F_{max} guaranteed for functionality only. V_{OL} and V_{OH} levels are guaranteed at DC only.
10. Skews are measured between outputs under identical conditions.
11. 200 mV input guarantees full logic swing at the output.

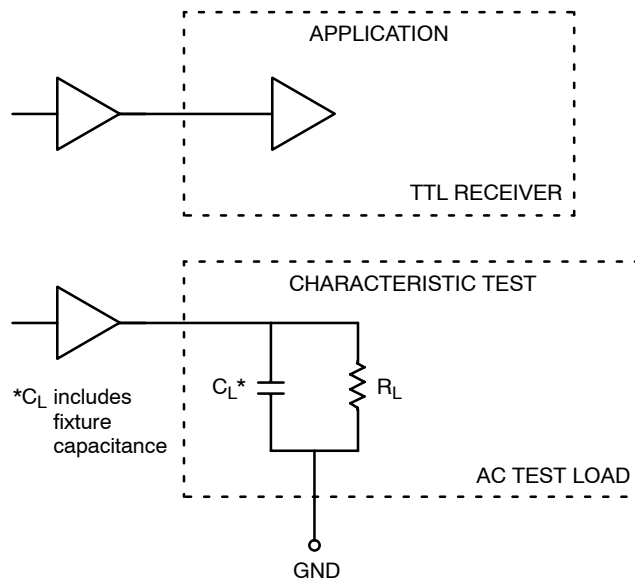

Figure 2. TTL Output Loading Used for Device Evaluation

MC100LVELT23

ORDERING INFORMATION

Device	Package	Shipping†
MC100LVELT23D	SOIC-8	98 Units / Rail
MC100LVELT23DG	SOIC-8 (Pb-Free)	98 Units / Rail
MC100LVELT23DR2	SOIC-8	2500 / Tape & Reel
MC100LVELT23DR2G	SOIC-8 (Pb-Free)	2500 / Tape & Reel
MC100LVELT23DT	TSSOP-8	100 Units / Rail
MC100LVELT23DTG	TSSOP-8 (Pb-Free)	100 Units / Rail
MC100LVELT23DTR2	TSSOP-8	2500 / Tape & Reel
MC100LVELT23DTRG	TSSOP-8 (Pb-Free)	2500 / Tape & Reel
MC100LVELT23MNR4	DFN8	1000 / Tape & Reel
MC100LVELT23MNR4G	DFN8 (Pb-Free)	1000 / Tape & Reel

†For information on tape and reel specifications, including part orientation and tape sizes, please refer to our Tape and Reel Packaging Specifications Brochure, BRD8011/D.

Resource Reference of Application Notes

- AN1405/D** - ECL Clock Distribution Techniques
- AN1406/D** - Designing with PECL (ECL at +5.0 V)
- AN1503/D** - ECLinPS™ I/O SPICE Modeling Kit
- AN1504/D** - Metastability and the ECLinPS Family
- AN1568/D** - Interfacing Between LVDS and ECL
- AN1672/D** - The ECL Translator Guide
- AND8001/D** - Odd Number Counters Design
- AND8002/D** - Marking and Date Codes
- AND8020/D** - Termination of ECL Logic Devices
- AND8066/D** - Interfacing with ECLinPS
- AND8090/D** - AC Characteristics of ECL Devices

MC100LVELT23

PACKAGE DIMENSIONS

SOIC-8 NB
CASE 751-07
ISSUE AH

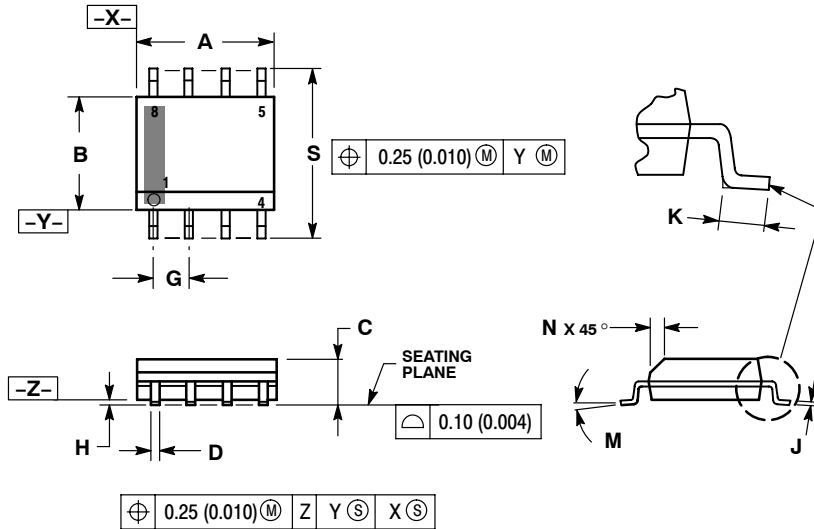

NOTES:

1. DIMENSIONING AND TOLERANCING PER ANSI Y14.5M, 1982.
2. CONTROLLING DIMENSION: MILLIMETER.
3. DIMENSION A AND B DO NOT INCLUDE MOLD PROTRUSION.
4. MAXIMUM MOLD PROTRUSION 0.15 (0.006) PER SIDE.
5. DIMENSION D DOES NOT INCLUDE DAMBAR PROTRUSION. ALLOWABLE DAMBAR PROTRUSION SHALL BE 0.127 (0.005) TOTAL IN EXCESS OF THE D DIMENSION AT MAXIMUM MATERIAL CONDITION.
6. 751-01 THRU 751-06 ARE OBSOLETE. NEW STANDARD IS 751-07.

DIM	MILLIMETERS		INCHES	
	MIN	MAX	MIN	MAX
A	4.80	5.00	0.189	0.197
B	3.80	4.00	0.150	0.157
C	1.35	1.75	0.053	0.069
D	0.33	0.51	0.013	0.020
G	1.27 BSC		0.050 BSC	
H	0.10	0.25	0.004	0.010
J	0.19	0.25	0.007	0.010
K	0.40	1.27	0.016	0.050
M	0°	8°	0°	8°
N	0.25	0.50	0.010	0.020
S	5.80	6.20	0.228	0.244

SOLDERING FOOTPRINT*

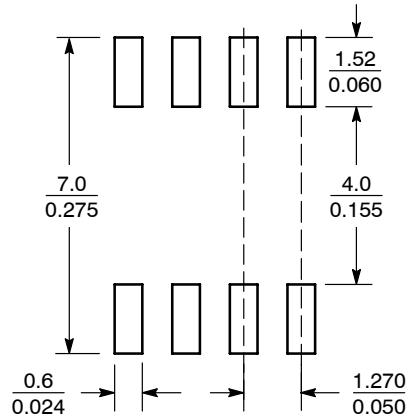

SCALE 6:1 ($\frac{\text{mm}}{\text{inches}}$)

*For additional information on our Pb-Free strategy and soldering details, please download the ON Semiconductor Soldering and Mounting Techniques Reference Manual, SOLDERRM/D.

MC100LVELT23

PACKAGE DIMENSIONS

TSSOP-8
DT SUFFIX
PLASTIC TSSOP PACKAGE
CASE 948R-02
ISSUE A

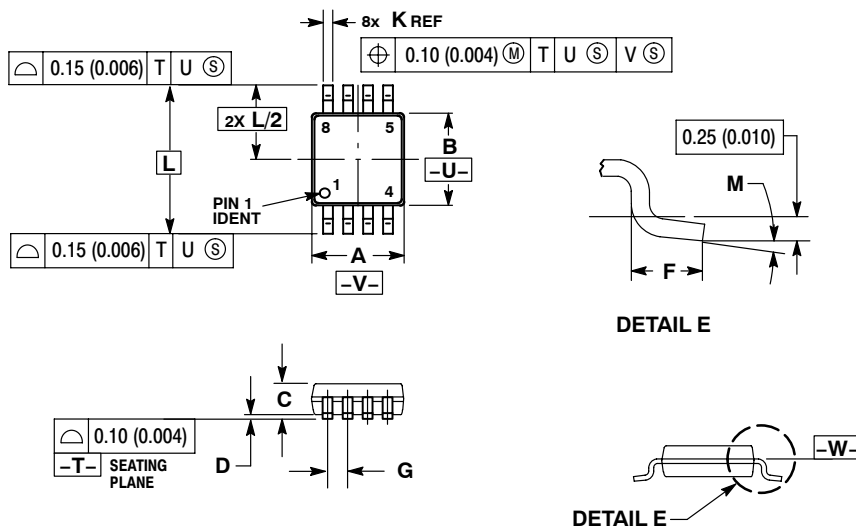

NOTES:

1. DIMENSIONING AND TOLERANCING PER ANSI Y14.5M, 1982.
2. CONTROLLING DIMENSION: MILLIMETER.
3. DIMENSION A DOES NOT INCLUDE MOLD FLASH, PROTRUSIONS OR GATE BURRS. MOLD FLASH OR GATE BURRS SHALL NOT EXCEED 0.15 (0.006) PER SIDE.
4. DIMENSION B DOES NOT INCLUDE INTERLEAD FLASH OR PROTRUSION. INTERLEAD FLASH OR PROTRUSION SHALL NOT EXCEED 0.25 (0.010) PER SIDE.
5. TERMINAL NUMBERS ARE SHOWN FOR REFERENCE ONLY.
6. DIMENSION A AND B ARE TO BE DETERMINED AT DATUM PLANE -W-.

DIM	MILLIMETERS		INCHES	
	MIN	MAX	MIN	MAX
A	2.90	3.10	0.114	0.122
B	2.90	3.10	0.114	0.122
C	0.80	1.10	0.031	0.043
D	0.05	0.15	0.002	0.006
F	0.40	0.70	0.016	0.028
G	0.65 BSC		0.026 BSC	
K	0.25	0.40	0.010	0.016
L	4.90 BSC		0.193 BSC	
M	0°	6°	0°	6°

MC100LVELT23

PACKAGE DIMENSIONS

DFN8
CASE 506AA-01
ISSUE D

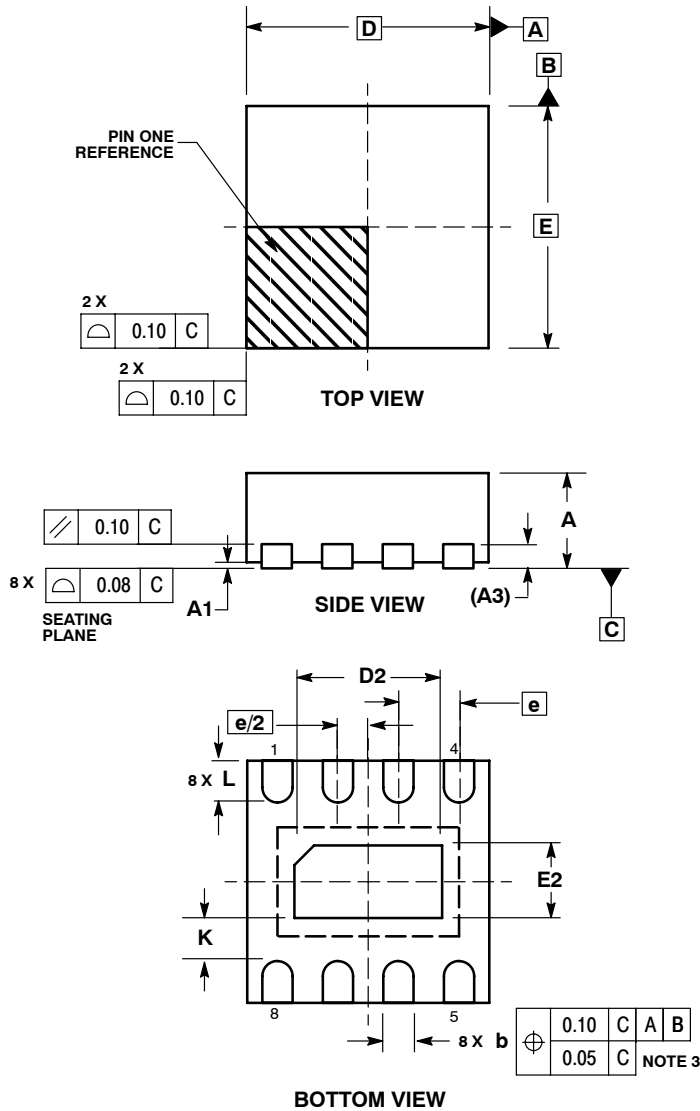

NOTES:

1. DIMENSIONING AND TOLERANCING PER ASME Y14.5M, 1994 .
2. CONTROLLING DIMENSION: MILLIMETERS.
3. DIMENSION b APPLIES TO PLATED TERMINAL AND IS MEASURED BETWEEN 0.25 AND 0.30 MM FROM TERMINAL.
4. COPLANARITY APPLIES TO THE EXPOSED PAD AS WELL AS THE TERMINALS.

DIM	MILLIMETERS	
	MIN	MAX
A	0.80	1.00
A1	0.00	0.05
A3	0.20 REF	
b	0.20	0.30
D	2.00 BSC	
D2	1.10	1.30
E	2.00 BSC	
E2	0.70	0.90
e	0.50 BSC	
K	0.20	---
L	0.25	0.35

ECLinPS is a trademark of Semiconductor Components Industries, LLC (SCILLC).

ON Semiconductor and are registered trademarks of Semiconductor Components Industries, LLC (SCILLC). SCILLC reserves the right to make changes without further notice to any products herein. SCILLC makes no warranty, representation or guarantee regarding the suitability of its products for any particular purpose, nor does SCILLC assume any liability arising out of the application or use of any product or circuit, and specifically disclaims any and all liability, including without limitation special, consequential or incidental damages. "Typical" parameters which may be provided in SCILLC data sheets and/or specifications can and do vary in different applications and actual performance may vary over time. All operating parameters, including "Typicals" must be validated for each customer application by customer's technical experts. SCILLC does not convey any license under its patent rights nor the rights of others. SCILLC products are not designed, intended, or authorized for use as components in systems intended for surgical implant into the body, or other applications intended to support or sustain life, or for any other application in which the failure of the SCILLC product could create a situation where personal injury or death may occur. Should Buyer purchase or use SCILLC products for any such unintended or unauthorized application, Buyer shall indemnify and hold SCILLC and its officers, employees, subsidiaries, affiliates, and distributors harmless against all claims, costs, damages, and expenses, and reasonable attorney fees arising out of, directly or indirectly, any claim of personal injury or death associated with such unintended or unauthorized use, even if such claim alleges that SCILLC was negligent regarding the design or manufacture of the part. SCILLC is an Equal Opportunity/Affirmative Action Employer. This literature is subject to all applicable copyright laws and is not for resale in any manner.

PUBLICATION ORDERING INFORMATION

LITERATURE FULFILLMENT:
Literature Distribution Center for ON Semiconductor
P.O. Box 5163, Denver, Colorado 80217 USA
Phone: 303-675-2175 or 800-344-3860 Toll Free USA/Canada
Fax: 303-675-2176 or 800-344-3867 Toll Free USA/Canada
Email: orderlit@onsemi.com

N. American Technical Support: 800-282-9855 Toll Free
USA/Canada
Europe, Middle East and Africa Technical Support:
Phone: 421 33 790 2910
Japan Customer Focus Center
Phone: 81-3-5773-3850

ON Semiconductor Website: www.onsemi.com
Order Literature: <http://www.onsemi.com/orderlit>
For additional information, please contact your local Sales Representative