



LM317M

LINEAR INTEGRATED CIRCUIT

3-TERMINAL 0.5A POSITIVE ADJUSTABLE REGULATOR

DESCRIPTION

The UTC LM317M is a 3-terminal adjustable positive voltage regulator capable of supplying in excess of 500mA over an output voltage range of 1.2V ~ 37V. This voltage regulator is exceptionally easy to use and requires only two external resistors to set the output voltage.

FEATURES

- *Output Current in Excess of 0.5A
- *Output Adjustable Between 1.2V and 37V
- *Internal Thermal Overload Protection
- *Internal Short Circuit Current Limiting
- *Output Transistor Safe Area Compensation
- *Floating Operation for High Voltage Applications

ORDERING INFORMATION

Order Number		Package	Pin Assignment			Packing
Normal	Lead Free Plating		1	2	3	
LM317M-AA3-0-R	LM317ML-AA3-0-R	SOT-223	A	O	I	Tape Reel
LM317M-TA3-0-T	LM317ML-TA3-0-T	TO-220	A	O	I	Tube
LM317M-TN3-0-R	LM317ML-TN3-0-R	TO-252	A	O	I	Tape Reel
LM317M-TN3-0-T	LM317ML-TN3-0-T	TO-252	A	O	I	Tube

Note: Pin assignment: I:V_{IN} O:V_{OUT} A:ADJ

<p>LM317ML-AA3-0-R</p> <p>(1)Packing Type (2)Pin Assignment (3)Package Type (4)Lead Plating</p>	<p>(1) R: Tape Reel, T: Tube (2) refer to Pin Assignment (3) AA3: SOT-223, TA3: TO-220, TN3: TO-252 (4) L: Lead Free Plating, Blank: Pb/Sn</p>
---	--

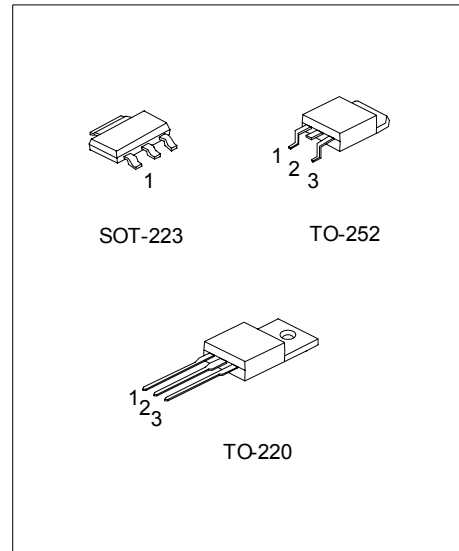

*Pb-free plating product number: LM317ML

■ BLOCK DIAGRAM

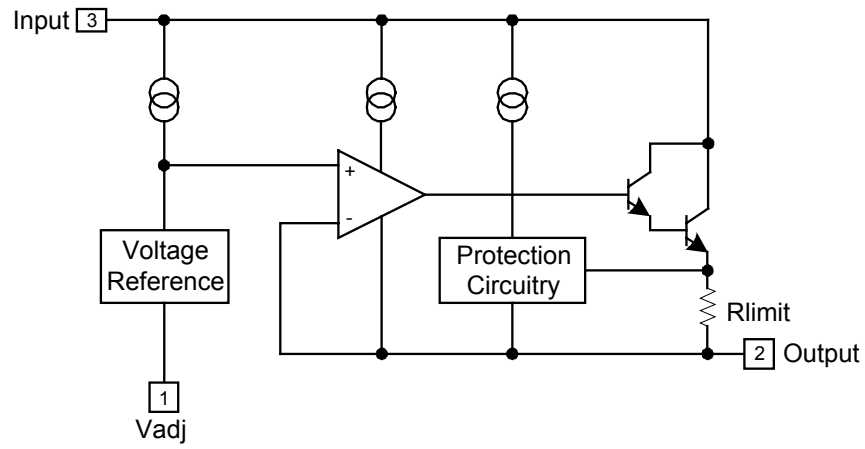

■ ABSOLUTE MAXIMUM RATINGS

PARAMETER	SYMBOL	RATINGS	UNIT
Input-Output Voltage Differential	$V_{IN}-V_{OUT}$	40	V
Power Dissipation	P_D	Internally Limited	W
Junction Temperature	T_J	+125	°C
Operating Temperature	T_{OPR}	-20 ~ +85	°C
Storage Temperature	T_{STG}	-40 ~ +150	°C

Note 1. Absolute maximum ratings are those values beyond which the device could be permanently damaged. Absolute maximum ratings are stress ratings only and functional device operation is not implied.

2. The device is guaranteed to meet performance specification within 0°C~+70°C operating temperature range and assured by design from -20°C~+85°C.

■ ELECTRICAL CHARACTERISTICS

($V_{IN}-V_{OUT}=5V$, $I_{OUT}=0.1A$, $0^\circ C \leq T_J \leq +125^\circ C$, $P_{D(MAX)}=7.5W$, unless otherwise specified.)

PARAMETER	SYMBOL	TEST CONDITIONS	MIN	TYP	MAX	UNIT
Line Regulation	ΔV_{OUT}	$T_a=+25^\circ C$, $3V \leq V_{IN}-V_{OUT} \leq 40V$		0.01	0.04	%/V
		$3V \leq V_{IN}-V_{OUT} \leq 40V$		0.02	0.07	
Load Regulation	ΔV_{OUT}	$T_a=+25^\circ C$, $10mA \leq V_{IN}-V_{OUT} \leq 0.5A$ $V_{OUT} \leq 5V$ $V_{OUT} \geq 5V$		5 0.1	25 0.5	mV %/V _o
		$10mA \leq I_{OUT} \leq 0.5A$ $V_{OUT} \leq 5V$ $V_{OUT} \geq 5V$		20 0.3	70 1.5	mV %/V _o
Adjustment Pin Current	I_{ADJ}			50	100	μA
Adjustment Pin Current Change	ΔI_{ADJ}	$3V \leq V_{IN}-V_{OUT} \leq 40V$ $10mA \leq I_{OUT} \leq 0.5A$, $P_D < P_{D(MAX)}$		0.2	5	μA
Reference Voltage	V_{REF}	$3V \leq V_{IN}-V_{OUT} \leq 40V$ $10mA \leq I_{OUT} \leq 0.5A$, $P_D < P_{D(MAX)}$	1.20	1.25	1.30	V
Temperature Stability	ST_T			0.7		%/V _o
Minimum Load Current to Maintain Regulation	$I_{L(MIN)}$	$V_{IN}-V_{OUT}=40V$		3.5	10	mA
Maximum Output Current	$I_{O(MAX)}$	$V_{IN}-V_{OUT} \leq 15V$, $P_D < P_{D(MAX)}$	0.5	0.9		
		$V_{IN}-V_{OUT}=40V$ $P_D < P_{D(MAX)}$, $T_a=+25^\circ C$	0.15	0.25		A
RMS Noise, % of V_{OUT}	eN	$T_a=+25^\circ C$, $10Hz < f < 10KHz$		0.003		%/V _o
Ripple Rejection	RR	$V_{OUT}=10V$, $f=120Hz$ Without C_{ADJ} $C_{ADJ}=10\mu F$	66	65 80		V/μs
Long-Term Stability	ST	$T_J=+125^\circ C$, 1000Hours		0.3	1	%/1000Hrs

■ TYPICAL APPLICATION

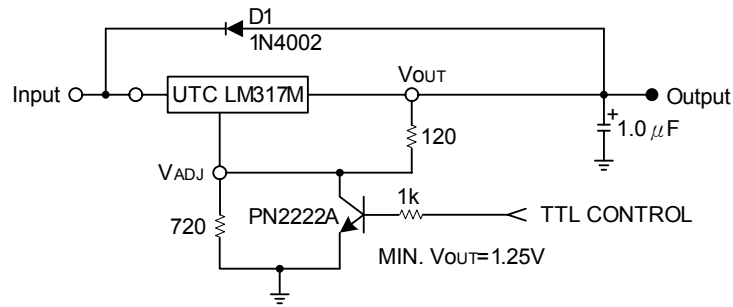

Figure 1. 1.5V Electronic Shutdown Regulator
D1 protects the device during an input short circuit

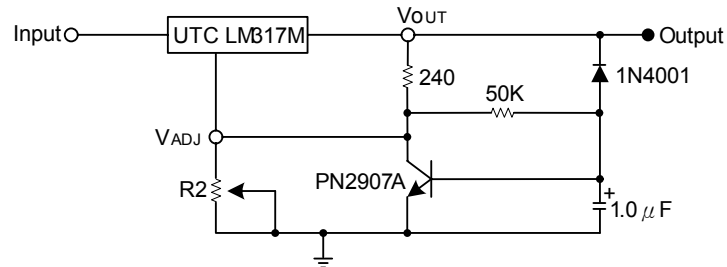
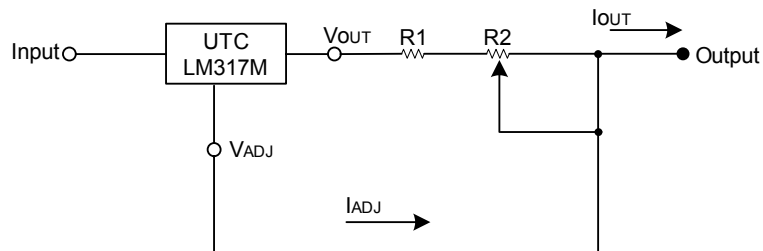

Figure 2. Slow Turn-On Regulator



$$I_{O(MAX)} = \left(\frac{V_{REF}}{R1} \right) + I_{ADJ} = \frac{1.25V}{R1}$$

$$I_{O(MIN)} = \left(\frac{V_{REF}}{R1+R2} \right) + I_{ADJ} = \frac{1.25V}{R1+R2}$$

5mA < I_{OUT} < 500mA

Figure 3. Current Regulator

TYPICAL CHARACTERISTICS

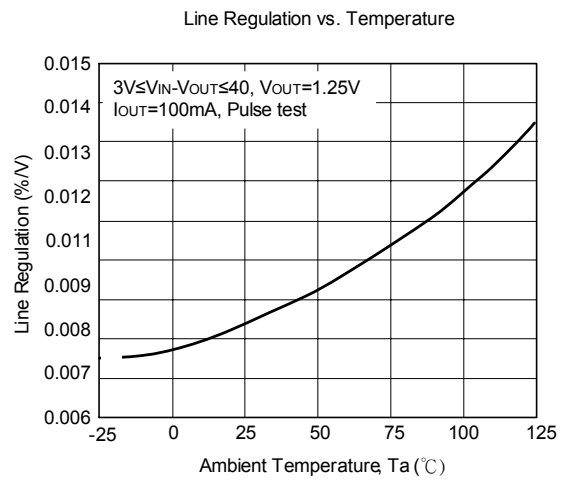
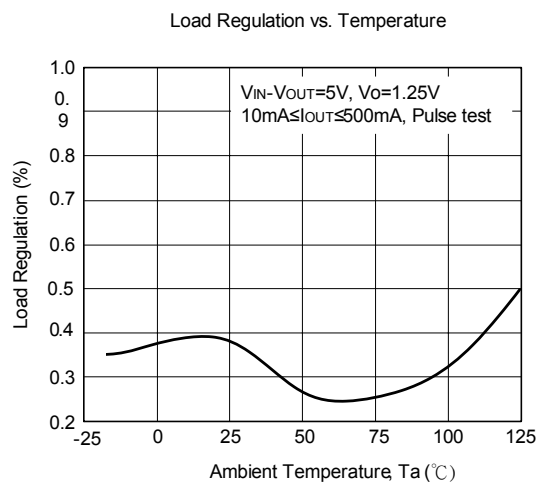
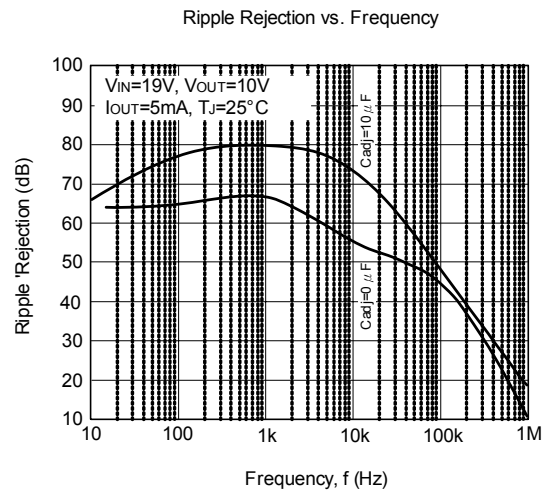
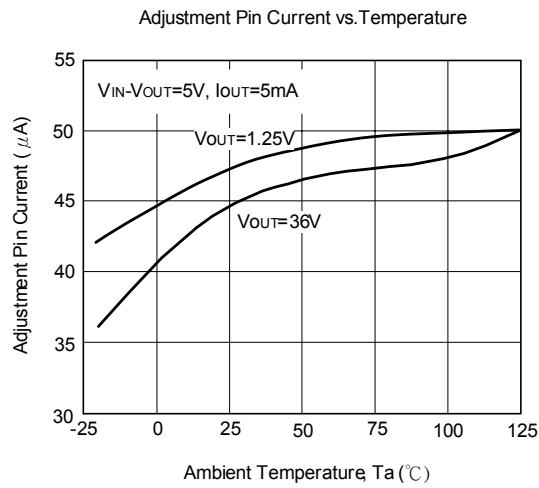
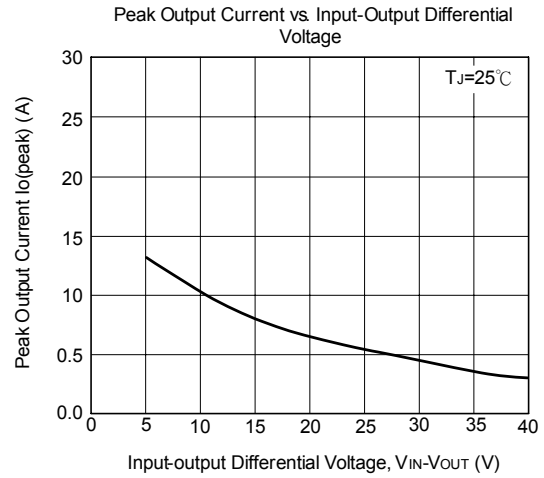
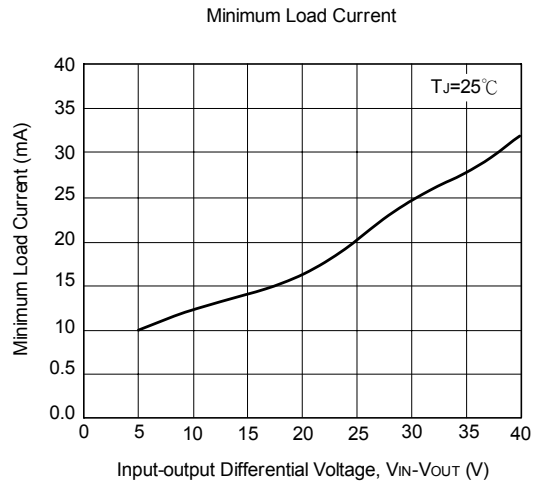

■ TYPICAL CHARACTERISTICS(Cont.)

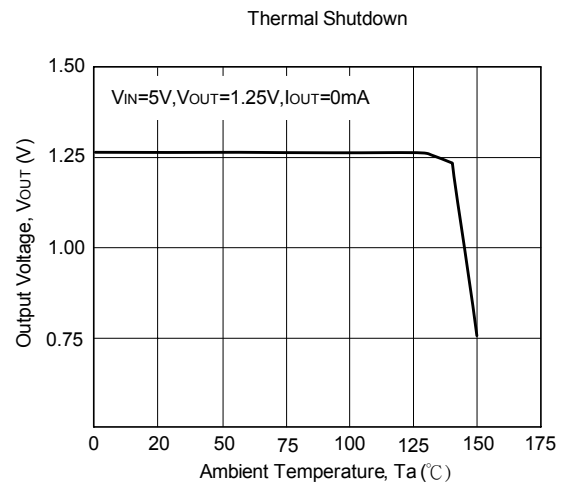
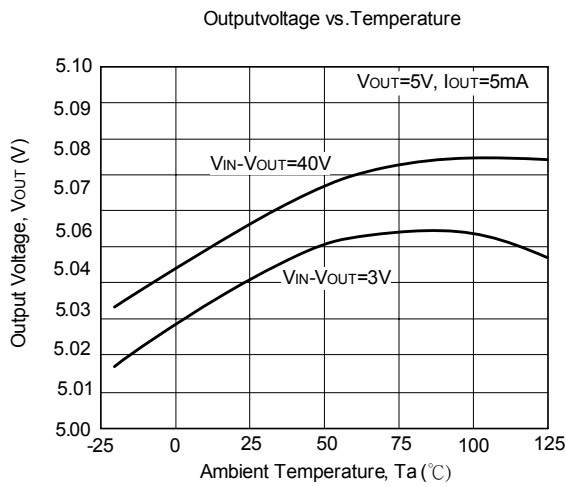

UTC assumes no responsibility for equipment failures that result from using products at values that exceed, even momentarily, rated values (such as maximum ratings, operating condition ranges, or other parameters) listed in products specifications of any and all UTC products described or contained herein. UTC products are not designed for use in life support appliances, devices or systems where malfunction of these products can be reasonably expected to result in personal injury. Reproduction in whole or in part is prohibited without the prior written consent of the copyright owner. The information presented in this document does not form part of any quotation or contract, is believed to be accurate and reliable and may be changed without notice.