

FAN2013

2A Low-Voltage Current-Mode Synchronous PWM Buck Regulator

Features

- 95% Efficiency, Synchronous Operation
- Adjustable Output Voltage from 0.8V to V_{IN}
- 4.5V to 5.5V Input Voltage Range
- Up to 2A Output Current
- Fixed-Frequency 1.3MHz PWM Operation
- 100% Duty Cycle, Low-Dropout Operation
- Soft-Start Function
- Excellent Load Transient Response
- Power-Good Flag
- Over-Voltage, Under-Voltage Lockout, Short-Circuit, and Thermal Shutdown Protections
- 3x3mm 6-lead MLP Package

Applications

- Hard Disk Drive
- Set-Top Box
- Point-of-Load Power
- Notebook Computer
- Communications Equipment

Description

The FAN2013 is a high-efficiency, low-noise synchronous PWM current mode DC-DC converter designed for low-voltage applications. It provides up to 2A continuous load current from the 4.5V to 5.5V input. The output voltage is adjustable over a wide range of 0.8V to V_{IN} by means of an external voltage divider.

The FAN2013 is enabled when the input voltage on the V_{IN} pin exceeds the UVLO threshold.

A current-mode control loop with a fast transient response ensures excellent line and load regulation. The fixed 1.3MHz switching frequency enables designers to choose a small, inexpensive external inductor and capacitor. Filtering can be accomplished with small components, reducing space and cost.

Protection features include input under-voltage lockout, short-circuit protection, and thermal shutdown. Soft-start limits in-rush current during start-up conditions.

The device is available in a 3x3mm 6-lead MLP.

Typical Application

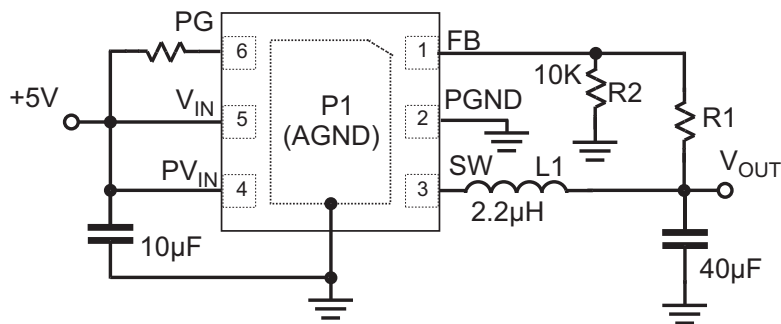

Figure 1. Typical Application

Ordering Information

Part Number	Output Voltage	Pb-Free	Package Type	Packing Method
FAN2013MPX	0.8V - V_{IN}	Yes	MLP-6 3x3mm	Tape and Reel

Pin Assignment

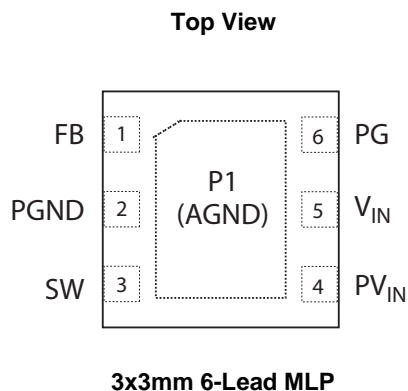

Figure 2. FAN2013 Pin Assignment

Pin Description

Pin #	Name	Description
P1	AGND	Analog Ground. P1 must be soldered to the PCB ground.
1	FB	Feedback Input. Adjustable voltage option; connect this pin to the resistor divider.
2	PGND	Power Ground. This pin is connected to the internal MOSFET switches. This pin must be externally connected to AGND.
3	SW	Switching Node. This pin is connected to the internal MOSFET switches.
4	PV _{IN}	Supply Voltage Input. This pin is connected to the internal MOSFET switches.
5	V _{IN}	Supply Voltage Input.
6	PG	Open Drain Power Good.

Absolute Maximum Ratings

Stresses above those listed under "Absolute Maximum Ratings" may cause permanent damage to the device. This is a stress rating only; functional operation of the device at these or any other conditions above those indicated in the operational section of this specification is not implied. Exposure to absolute maximum rating conditions for extended periods may affect device reliability. Absolute maximum ratings apply individually only, not in combination. Unless otherwise specified, all other voltages are referenced to AGND.

Symbol	Parameter	Min.	Max.	Unit.
V_{IN}	Supply Voltage	-0.3	6.2	V
	PV_{IN} and any other pin	-0.3	V_{IN}	V
θ_{JC}	Thermal Resistance-Junction to Tab, 3x3mm 6-lead MLP ⁽¹⁾		8	°C/W
T_L	Lead Soldering Temperature (10 seconds)		260	°C
T_{STG}	Storage Temperature	-65	150	°C
T_J	Junction Temperature	-40	150	°C
	Electrostatic Discharge (ESD) Protection Level ⁽²⁾	HBM	3.5	kV
		CDM	2	

Notes:

1. Junction-to-ambient thermal resistance, θ_{JA} , is a strong function of PCB material, board thickness, thickness and number of copper planes, number of via used, diameter of via used, available copper surface, and attached heat sink characteristics.
2. Using Mil Std. 883E, method 3015.7 (Human Body Model) and EIA/JESD22C101-A (Charge Device Model).

Recommended Operating Conditions

Symbol	Parameter	Min.	Typ.	Max.	Unit
V_{IN}	Supply Voltage Range	4.5		5.5	V
V_{OUT}	Output Voltage Range, Adjustable Version	0.8		V_{IN}	V
I_{OUT}	Output Current			2.0	A
L	Inductor ⁽³⁾		2.2		μ H
C_{IN}	Input Capacitor ⁽³⁾	10	20		μ F
C_{OUT}	Output Capacitor ⁽³⁾	20	40		μ F
T_A	Operating Ambient Temperature Range	-40		+85	°C

Notes:

3. Refer to the Applications Information section for further details.

Electrical Characteristics

$V_{IN} = 4.5V$ to $5.5V$, $V_{OUT} = 1.2V$, $I_{OUT} = 200mA$, $C_{IN} = 10\mu F$, $C_{OUT} = 40\mu F$, $L = 2.2\mu H$, $T_A = -40^{\circ}C$ to $+85^{\circ}C$, unless otherwise noted. Typical values are at $T_A = 25^{\circ}C$.

Parameter	Conditions	Min.	Typ.	Max.	Units
Input Voltage		4.5		5.5	V
Quiescent Current	$I_{OUT} = 0mA$		5	10	mA
UVLO Threshold	V_{IN} rising	3.5	3.7	4.0	V
	Hysteresis		150		mV
PMOS On Resistance	$V_{IN} = V_{GS} = 5V$		90		$m\Omega$
NMOS On Resistance	$V_{IN} = V_{GS} = 5V$		90		$m\Omega$
P-Channel Current Limit	$4.5V < V_{IN} < 5.5V$	2.8	3.5	4.2	A
Over-Temperature Protection	Rising temperature		150		$^{\circ}C$
	Hysteresis		20		$^{\circ}C$
Switching Frequency		1000	1300	1600	kHz
Line Regulation	$V_{IN} = 4.5$ to $5.5V$ $I_{OUT} = 100mA$		0.16		%/V
Load Regulation	$0mA \leq I_{OUT} \leq 2000mA$		0.2	0.6	%
Output Voltage During Load Transition ⁽⁴⁾	I_{OUT} from $1500mA$ to $100mA$ $C_{OUT} = 60\mu F$			5	%
Output Voltage During Load Transition ⁽⁴⁾	I_{OUT} from $100mA$ to $1500mA$ $C_{OUT} = 60\mu F$	-5			%
Reverse Leakage Current into Pin SW	$V_{IN} = \text{Open}$, $EN = GND$, $V_{sw} = 5.5V$		0.1	1	μA
Reference Voltage, V_{REF}			0.8		V
Output Voltage Accuracy	$V_{IN} = 4.5$ to $5.5V$ $0mA \leq I_{OUT} \leq 2000mA$ $T_A = 0C$ to $+85C$	-2		2	%
	$V_{IN} = 4.5$ to $5.5V$ $0mA \leq I_{OUT} \leq 2000mA$ $T_A = -40C$ to $+85C$	-3		3	%
Power Good Output Threshold and Hysteresis	FB voltage rising		$0.95 \times V_{OUT}$		V
	Hysteresis		2		%
Power Good Output Delay			100		μs
Power Good Output Voltage Low	$I_{sink} = 6mA$, open drain output			0.4	V
Over-Voltage Protection (OVP) Threshold and Hysteresis	FB voltage rising		$1.07 \times V_{OUT}$		V
	Hysteresis		2		%

Notes:

- Refer to the load transient response test waveform in Figure 3.

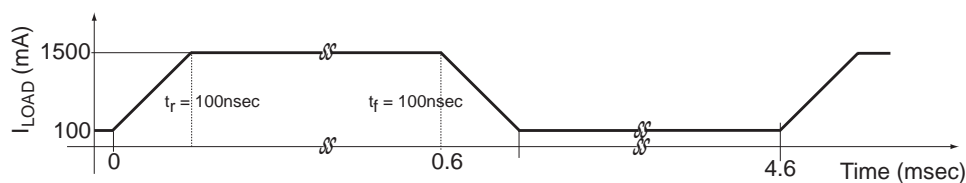

Figure 3. Load Transient Response Test Waveform

Typical Performance Characteristics

$T_A = 25^\circ\text{C}$, $C_{IN} = 10\mu\text{F}$, $C_{OUT} = 40\mu\text{F}$, $L = 2.2\mu\text{H}$, $V_{IN} = 5\text{V}$, $V_{OUT} = 1.2\text{V}$ unless otherwise noted.

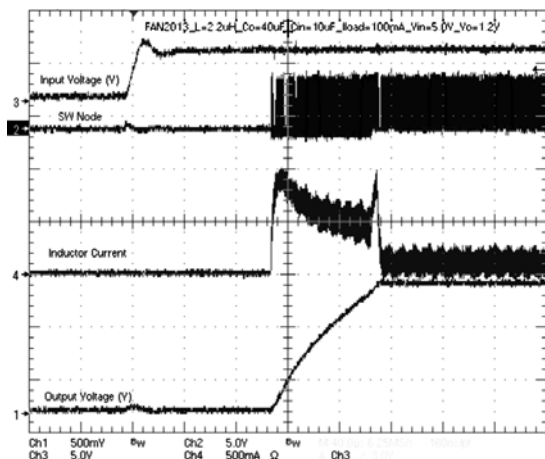

Figure 4. Start-up with 100mA Resistive Load

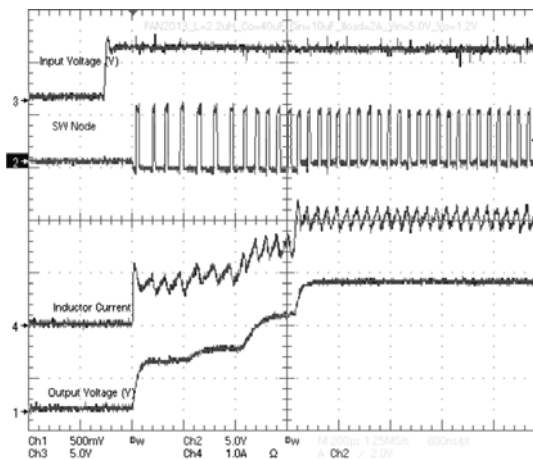

Figure 5. Start-up with 2A Resistive Load

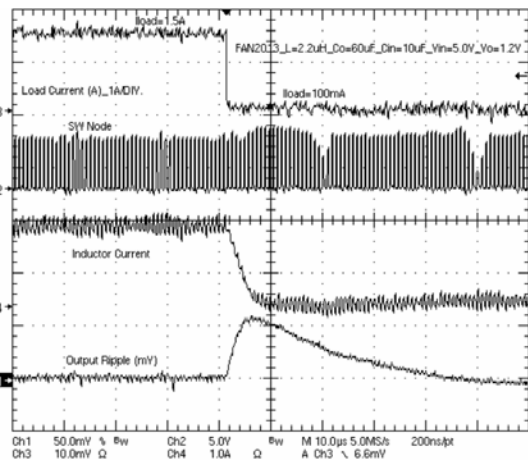

Figure 6. Load Transient Response 1.5A to 100mA

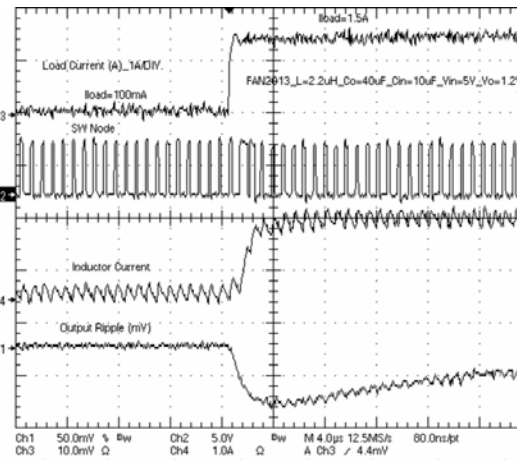

Figure 7. Load Transient Response 100mA to 1.5A

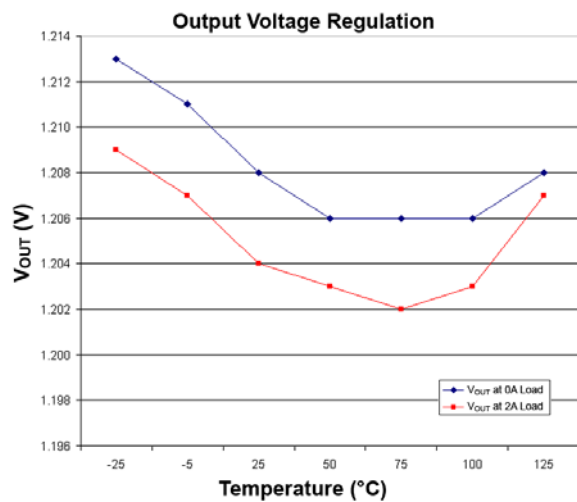

Figure 8. Output Voltage Regulation

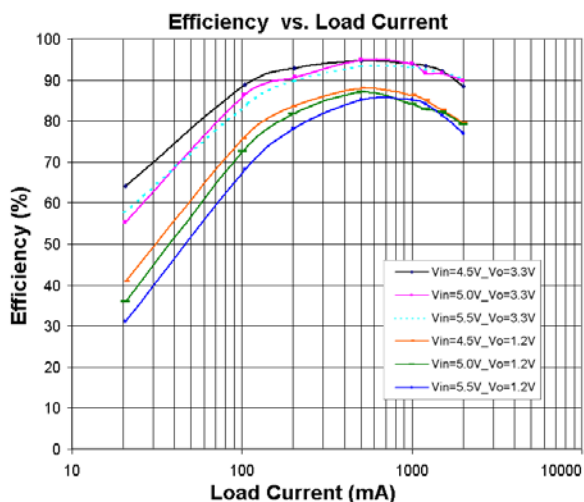

Figure 9. Power Efficiency

Block Diagram

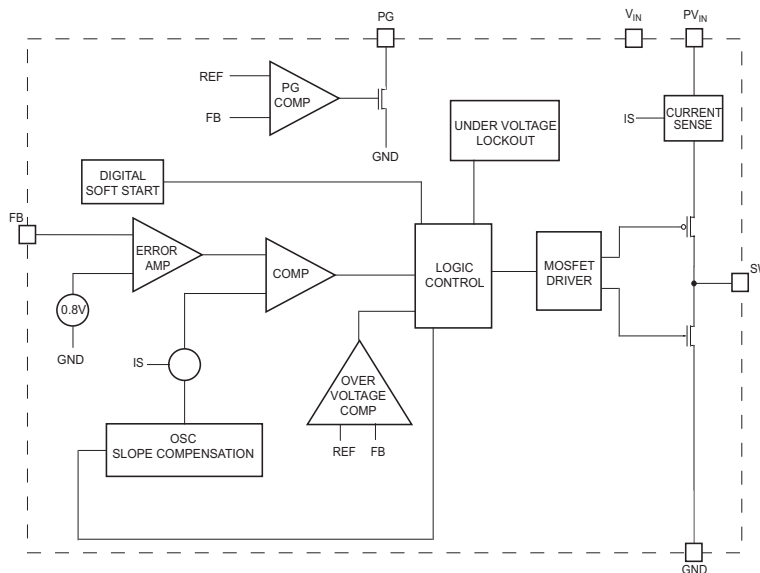

Figure 10. Block Diagram

Operation Description

The FAN2013 is a step-down pulse-width modulated (PWM) current mode converter with a fixed switching frequency of 1.3MHz. At the rising edge of each clock cycle, the P-channel transistor is turned on until the PWM comparator trips or the current limit is reached. During the ON time, the inductor current ramps up and is monitored by the internal current-mode control loop. After a minimum dead time, the N-channel transistor is turned ON and the inductor current ramps down. As the clock cycle is completed, the N-channel switch is turned OFF and the next clock cycle starts. The duty cycle is given by the ratio of output voltage and input voltage. The converter runs at minimum duty cycle when output voltage is at minimum and input voltage is at maximum, and at 100% duty cycle when the input voltage approaches the output voltage, as described below.

100% Duty Cycle Operation

As the input voltage approaches the output voltage and the duty cycle exceeds the typical 95%, the converter turns the P-channel transistor continuously on. In this mode, the output voltage is equal to the input voltage, minus the voltage drop across the P-channel transistor:

$$V_{OUT} = V_{IN} - I_{LOAD} \times (R_{DS_ON} + R_L) \quad \text{EQ 1}$$

where

R_{DS_ON} = P-channel switch ON resistance

I_{LOAD} = Output current

R_L = Inductor DC resistance

UVLO and Soft Start

The internal voltage reference, V_{REF} , and the IC remain reset until V_{IN} reaches the 3.7V UVLO threshold.

The FAN2013 has an internal soft-start circuit that limits the in-rush current during start-up. This prevents possi-

ble voltage drops of the input voltage and eliminates the output voltage overshoot. The soft-start is implemented as a digital circuit, increasing the switch current in four steps to the P-channel current limit (3.5A). Typical start-up time for a 40 μ F output capacitor with a load current of 2.0A is 800 μ s.

Output Over-Voltage Protection

When output voltage, V_{OUT} , reaches approximately 7% above the nominal value, the device turns OFF the P-channel switch and turns ON part of the N-channel transistor with a built-in current limit of about 400mA. When V_{OUT} reaches the hysteresis of about 2%, the device starts switching normally in closed loop. If output voltage is pulled up by an external voltage source with a current limit higher than typical 400mA, the output voltage stays up at the external voltage source level.

The over-voltage protection is designed to limit the output voltage excursion in case of a transient response from full load to a minimum load.

Output Short-Circuit Protection

The switch peak current is limited cycle by cycle to a typical value of 3.5A. In the event of an output voltage short circuit, the device operates with a frequency of 400kHz and minimum duty cycle, making the average typical input current .45A.

Thermal Shutdown

When the die temperature exceeds 150°C, a reset occurs and remains in effect until the die cools to 130°C, when the circuit is allowed to restart.

Applications Information

Setting the Output Voltage

The internal voltage reference, V_{REF} , is 0.8V. The output is divided down by a voltage divider, R1 and R2 to the FB pin. The output voltage is:

$$V_{OUT} = V_{REF} \left(1 + \frac{R_1}{R_2} \right) \quad \text{EQ 2}$$

According to this equation, assuming desired output voltage of 1.2V, and given $R_2 = 10K\Omega$, the calculated value of R_1 is $5K\Omega$.

Inductor Selection

The inductor parameters directly related to device performance are saturation current and DC resistance. The FAN2013 operates with a typical inductor value of $2.2\mu H$. The lower the DC resistance, the higher the efficiency. For saturation current, the inductor should be rated higher than the maximum load current, plus half of the inductor ripple current, calculated by:

$$\Delta I_L = V_{OUT} \times \frac{1 - (V_{OUT}/V_{IN})}{L \times f} \quad \text{EQ 3}$$

where:

ΔI_L = Inductor Ripple Current

f = Switching Frequency

L = Inductor Value

Recommended inductors are listed in Table 1.

Inductor Value	Vendor	Part Number
2.2 μH	Coiltronics	SD25 2R2
2.2 μH	Murata	LQH66SSN2R2M03

Table 1: Recommended Inductors

Capacitors Selection

For best performance, a low-ESR input capacitor is required. A ceramic capacitor of at least $10\mu F$, placed as close to the V_{IN} and AGND pins as possible, is recommended.

The output capacitor determines the output voltage ripple and the transient response. A minimum $20\mu F$ output capacitor is required for the FAN2013 to operate in stable conditions.

Capacitor Value	Vendor	Part Number
10 μF	Taiyo Yuden	JMK212BJ106MG
		JMK316BJ106KL
	TDK	C2012X5ROJ106K
		C3216X5ROJ106M
	Murata	GRM32ER61C106K

Table 2: Recommended Capacitors

PCB Layout Recommendations

The inherently high peak currents and switching frequency of power supplies require careful PCB layout design. For best results, use wide traces for high-current paths and place the input capacitor, the inductor, and the output capacitor as close as possible to the integrated circuit terminals. To minimize voltage stress to the device resulting from ever-present switching spikes, use an input bypass capacitor with low ESR. Note that the peak amplitude of the switching spikes depends upon the load current; the higher the load current, the higher the switching spikes.

The resistor divider that sets the output voltage should be routed away from the inductor to avoid RF coupling. The ground plane at the bottom side of the PCB acts as an electromagnetic shield to reduce EMI. The recommended PCB layout is shown in Figure 11.

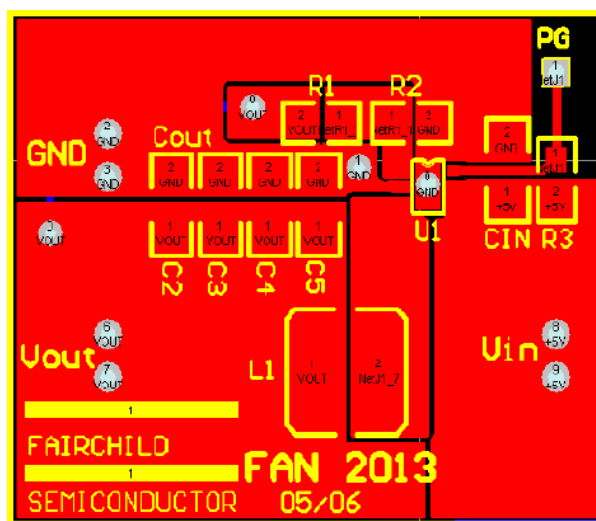
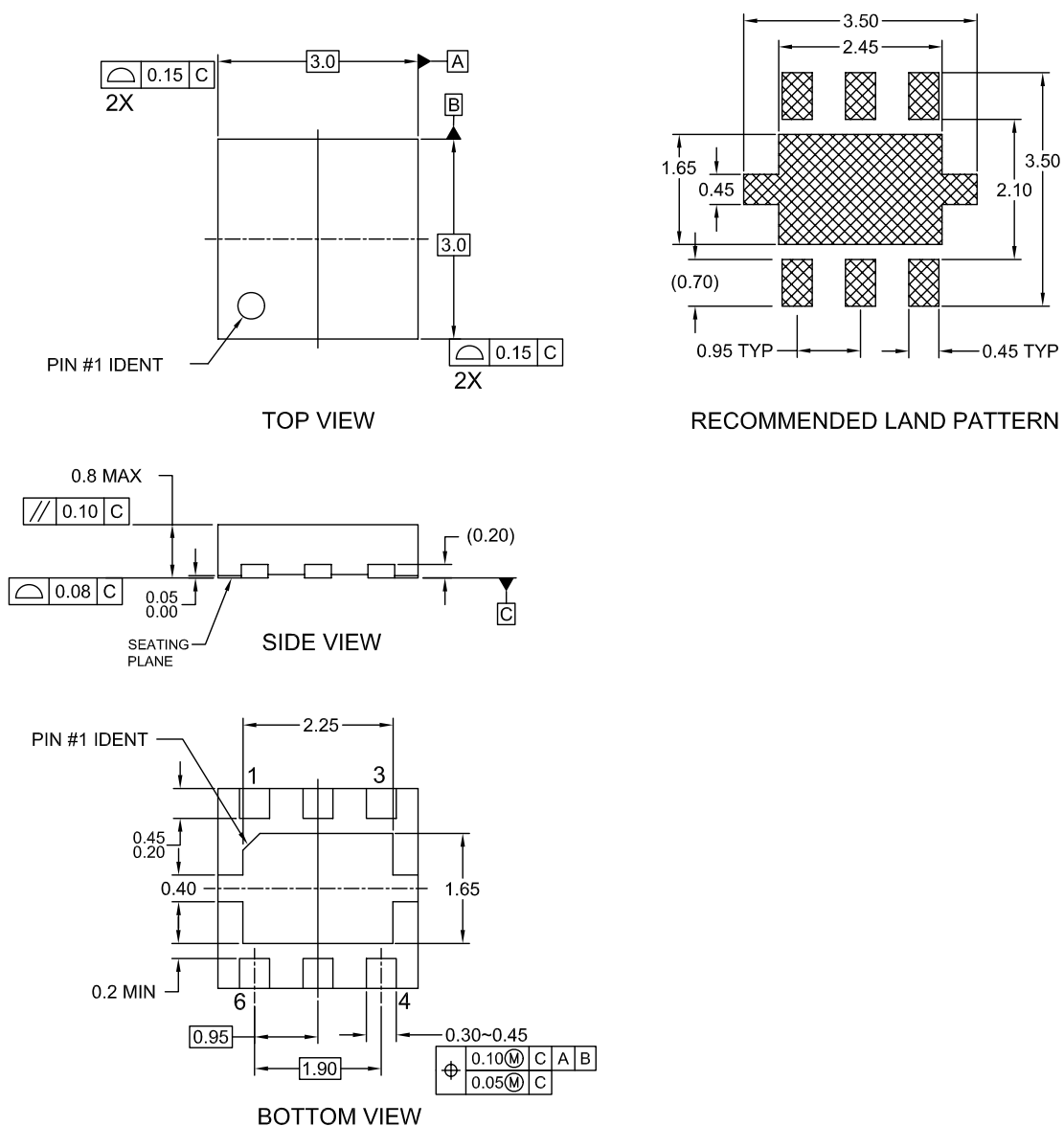

Figure 11. Recommended PCB Layout

Mechanical Dimensions

3x3mm 6-Lead MLP

Dimensions are in millimeters unless otherwise noted.



NOTES:

- A. CONFORMS TO JEDEC REGISTRATION MO-229, VARIATION WEEA, DATED 11/2001 EXCEPT FOR DAP EXTENSION TABS
- B. DIMENSIONS ARE IN MILLIMETERS.
- C. DIMENSIONS AND TOLERANCES PER ASME Y14.5M, 1994

MLP06FrevA

Figure 12. 3x3mm 6-Lead Molded Leadless Package (MLP)

TRADEMARKS

The following are registered and unregistered trademarks Fairchild Semiconductor owns or is authorized to use and is not intended to be an exhaustive list of all such trademarks.

ACE _x TM	FACT Quiet Series TM	OCX TM	SILENT SWITCHER [®]	UniFET TM
ActiveArray TM	GlobalOptoisolator TM	OCXPro TM	SMART START TM	UltraFET [®]
Bottomless TM	GTO TM	OPTOLOGIC [®]	SPM TM	VCX TM
Build it Now TM	HiSeC TM	OPTOPLANAR TM	Stealth TM	Wire TM
CoolFET TM	I ² C TM	PACMAN TM	SuperFET TM	
CROSSVOLT TM	i-Lo TM	POP TM	SuperSOT TM -.3	
DOME TM	ImpliedDisconnect TM	Power247 TM	SuperSOT TM -.6	
EcoSPARK TM	IntelliMAX TM	PowerEdge TM	SuperSOT TM -.8	
E ² CMOS TM	ISOPLANAR TM	PowerSaver TM	SyncFET TM	
EnSigna TM	LittleFET TM	PowerTrench [®]	TCM TM	
FACT [®]	MICROCOUPLER TM	QFET [®]	TinyBoost TM	
FAST [®]	MicroFET TM	QS TM	TinyBuck TM	
FAST _r TM	MicroPak TM	QT Optoelectronics TM	TinyPWM TM	
FPST TM	MICROWIRE TM	Quiet Series TM	TinyPower TM	
FRFET TM	MSX TM	RapidConfigure TM	TinyLogic [®]	
	MSXPro TM	RapidConnect TM	TINYOPTO TM	
Across the board. Around the world. TM		μSerDes TM	TruTranslation TM	
The Power Franchise [®]		ScalarPump TM	UHC [®]	
Programmable Active Droop TM				

DISCLAIMER

FAIRCHILD SEMICONDUCTOR RESERVES THE RIGHT TO MAKE CHANGES WITHOUT FURTHER NOTICE TO ANY PRODUCTS HEREIN TO IMPROVE RELIABILITY, FUNCTION, OR DESIGN. FAIRCHILD DOES NOT ASSUME ANY LIABILITY ARISING OUT OF THE APPLICATION OR USE OF ANY PRODUCT OR CIRCUIT DESCRIBED HEREIN; NEITHER DOES IT CONVEY ANY LICENSE UNDER ITS PATENT RIGHTS, NOR THE RIGHTS OF OTHERS. THESE SPECIFICATIONS DO NOT EXPAND THE TERMS OF FAIRCHILD'S WORLDWIDE TERMS AND CONDITIONS, SPECIFICALLY THE WARRANTY THEREIN, WHICH COVERS THESE PRODUCTS.

LIFE SUPPORT POLICY

FAIRCHILD'S PRODUCTS ARE NOT AUTHORIZED FOR USE AS CRITICAL COMPONENTS IN LIFE SUPPORT DEVICES OR SYSTEMS WITHOUT THE EXPRESS WRITTEN APPROVAL OF FAIRCHILD SEMICONDUCTOR CORPORATION.

As used herein:

- Life support devices or systems are devices or systems which, (a) are intended for surgical implant into the body, or (b) support or sustain life, or (c) whose failure to perform when properly used in accordance with instructions for use provided in the labeling, can be reasonably expected to result in significant injury to the user.
- A critical component is any component of a life support device or system whose failure to perform can be reasonably expected to cause the failure of the life support device or system, or to affect its safety or effectiveness.

PRODUCT STATUS DEFINITIONS

Definition of Terms

Datasheet Identification	Product Status	Definition
Advance Information	Formative or In Design	This datasheet contains the design specifications for product development. Specifications may change in any manner without notice.
Preliminary	First Production	This datasheet contains preliminary data, and supplementary data will be published at a later date. Fairchild Semiconductor reserves the right to make changes at any time without notice to improve design.
No Identification Needed	Full Production	This datasheet contains final specifications. Fairchild Semiconductor reserves the right to make changes at any time without notice to improve design.
Obsolete	Not In Production	This datasheet contains specifications on a product that has been discontinued by Fairchild semiconductor. The datasheet is printed for reference information only.

Rev. I2I