



2SD2470

NPN SILICON TRANSISTOR

STROBO AND DC/DC CONVERTERS

■ FEATURES

- * Low saturation voltage
 $V = 0.25V(\text{typ})$ at $I_C/I_B = 3A/0.1A$
- * Collector current of 5A is possible

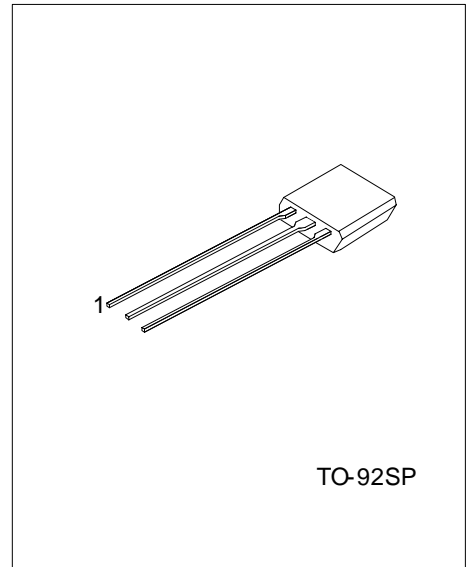

*Pb-free plating product number: 2SD2470L

■ ORDERING INFORMATION

Order Number		Package	Pin Assignment			Packing
Normal	Lead Free Plating		1	2	3	
2SD2470-x-T9S-K	2SD2470L-x-T92-K	TO-92SP	E	C	B	Bulk

<p>2SD2470L-x-T9S-K</p>	<p>(1) K: Bulk (2) T9S: TO-92SP (3) refer to Classification of h_{FE} (4) L: Lead Free Plating Blank: Pb/Sn</p>
-------------------------	---

2SD2470

NPN SILICON TRANSISTOR

■ ABSOLUTE MAXIMUM RATING (Ta=25)

PARAMETER	SYMBOL	RATINGS	UNIT
Collector-Base Voltage	V_{CBO}	15	V
Collector-Emitter Voltage	V_{CEO}	10	V
Emitter-Base Voltage	V_{EBO}	10	V
Collector Current (DC)	I_C	5	A
Collector Current (PULSE)*	I_{CP}	8	A
Collector Power Dissipation	P_C	0.4	W
Junction Temperature	T_J	+150	
Storage Temperature	T_{STG}	-55 ~ +150	

Note Absolute maximum ratings are those values beyond which the device could be permanently damaged.

Absolute maximum ratings are stress ratings only and functional device operation is not implied.

* Single Pulse =10ms

■ ELECTRICAL CHARACTERISTICS (Ta=25 , unless otherwise specified)

PARAMETER	SYMBOL	TEST CONDITIONS	MIN	TYP	MAX	UNIT
Collector Base Breakdown Voltage	BV_{CBO}	$I_C = 50\mu A$	15			V
Collector Emitter Breakdown Voltage	BV_{CEO}	$I_C = 1mA$	10			V
Emitter Base Breakdown Voltage	BV_{EBO}	$I_E = 50\mu A$	10			V
Collector Cut-Off Current	I_{CBO}	$V_{CB} = 10V, I_E = 0$			0.1	μA
Emitter Cut-Off Current	I_{EBO}	$V_{EB} = 8V, I_C = 0$			0.5	μA
DC Current Gain	h_{FE}	$V_{CE} = 2V, I_C = 2A$	270		820	
Collector-Emitter Saturation Voltage	$V_{CE(SAT)}$	$I_C/I_B = 3A / 0.1A$		0.25	0.5	V
Transition Frequency	f_T	$V_{CE} = 6V, I_E = 0.05A, f = 100MHz$		170		MHz
Output Capacitance	C_{ob}	$V_{CB} = 10V, I_E = 0A, f = 1MHz$		30		pF

■ CLASSIFICATION OF h_{FE}

RANK	S	E
RANGE	270~560	450~820

TYPICAL CHARACTERISTICS

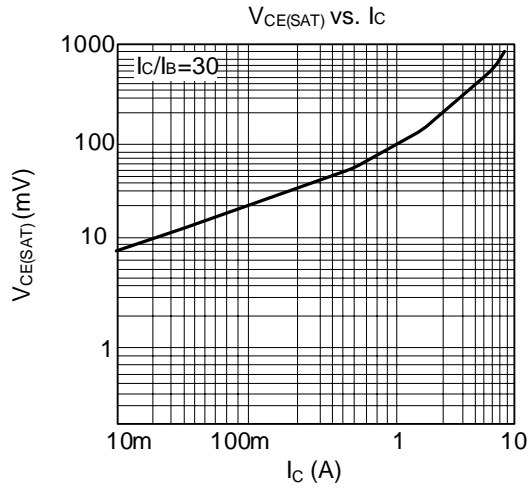

UTC assumes no responsibility for equipment failures that result from using products at values that exceed, even momentarily, rated values (such as maximum ratings, operating condition ranges, or other parameters) listed in products specifications of any and all UTC products described or contained herein. UTC products are not designed for use in life support appliances, devices or systems where malfunction of these products can be reasonably expected to result in personal injury. Reproduction in whole or in part is prohibited without the prior written consent of the copyright owner. The information presented in this document does not form part of any quotation or contract, is believed to be accurate and reliable and may be changed without notice.