

FEATURES

- **WIDE-BAND:** 2 to 8 GHz
- **HIGH GAIN:** 15 dB at $f = 2$ to 8 GHz
- **MEDIUM POWER:** +14 dBm TYP at $f = 2$ to 8 GHz
- **INPUT/OUTPUT IMPEDANCE MATCHED TO 50 Ω**
- **HERMETICALLY SEALED PACKAGE ASSURES HIGH RELIABILITY**

DESCRIPTION

The UPG110B is a GaAs monolithic integrated circuit designed for use as a wide-band amplifier from 2 GHz to 8 GHz. The device is most suitable for the gain stage of microwave communication systems where high gain characteristics are required. The UPG110 is available in a 4 pin flat package and in chip form.

GAIN vs. FREQUENCY AND TEMPERATURE

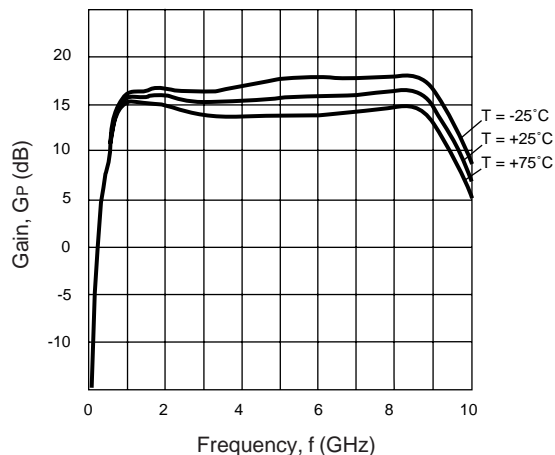

ELECTRICAL CHARACTERISTICS¹ ($T_A = 25 \pm 3^\circ\text{C}$, $Z_S = Z_L = 50 \Omega$, $V_{DD} = +8 \text{ V}$, $f = 2.0$ to 8.0 GHz)

PART NUMBER PACKAGE OUTLINE			UPG110B/P FA/CHIP		
SYMBOLS	PARAMETERS	UNITS	MIN	TYP	MAX
I_{DD}	Supply Current	mA	65	135	180
G_P	Power Gain	dB	12	15	
ΔG_L	Gain Flatness	dB			± 1.5
R_{LIN}	Input Return Loss	dB	6	10	
R_{LOUT}	Output Return Loss	dB	7	10	
I_{SOL}	Isolation	dB	30	40	
P_{1dB}	Output Power at 1 dB Compression Point	dBm	10	14	
IP_3	SSB Third Order Intercept Point	dBm		25	

Note:

1. When handling the device, a ground strap should be used to prevent electric static discharge (ESD) that can damage the IC.

ABSOLUTE MAXIMUM RATINGS¹ (T_A = 25°C)

SYMBOLS	PARAMETERS	UNITS	RATINGS
V _{DD}	Drain Voltage	V	+10
V _{IN}	Input Voltage	V	-5 to +0.6
P _{IN}	Input Power	dBm	+10
P _T	Total Power Dissipation	W	1.5
T _C	Case Temperature	°C	-65 to +125
T _{STG}	Storage Temperature	°C	-65 to +175

Note:

1. Operation in excess of any one of these parameters may result in permanent damage.

EQUIVALENT CIRCUIT

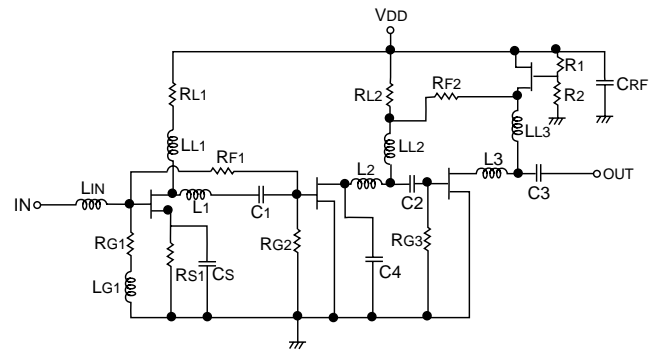

TYPICAL PERFORMANCE CURVES (T_A = 25°C)

INPUT/OUTPUT RETURN LOSS vs. FREQUENCY

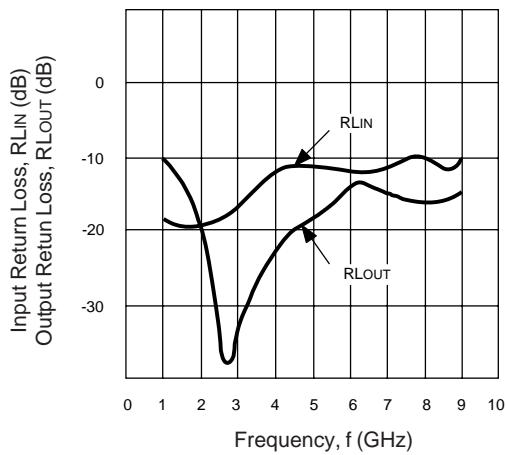

OUTPUT POWER vs. INPUT POWER AND FREQUENCY

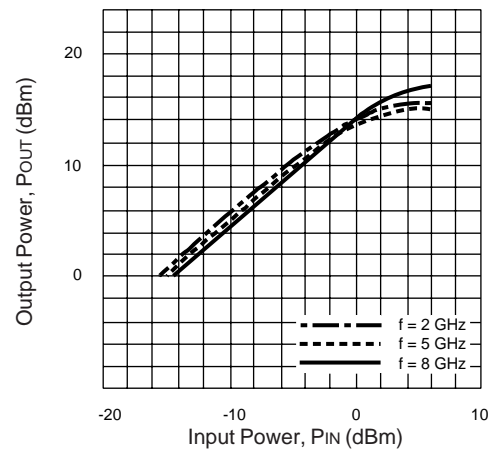

ISOLATION vs. FREQUENCY

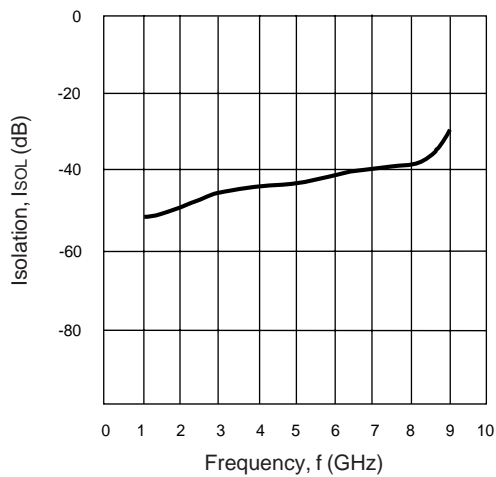

OUTPUT POWER vs. INPUT POWER AND GAIN CONTROL

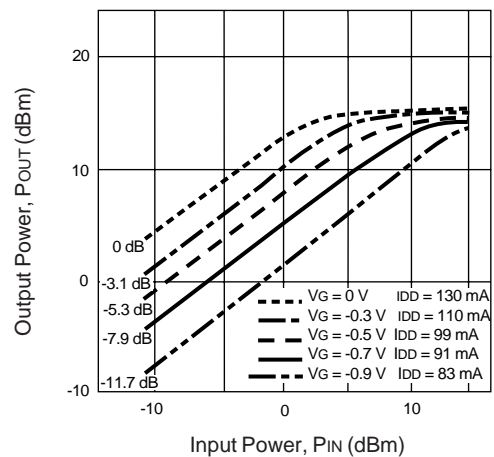

Note: Gain control can be achieved by applying a negative voltage (V_G) to the input pin.

TYPICAL SCATTERING PARAMETERS

UPG110B

VDD = 8V, IDD = 135 mA

FREQUENCY GHZ	S11		S21		S12		S22		K	S21 dB
	MAG	ANG	MAG	ANG	MAG	ANG	MAG	ANG		
0.05	0.375	-78	1.075	14	0.001	-171	0.967	-26	25.7	0.6
0.10	0.249	-101	2.899	-50	0.001	143	0.862	-51	41.6	9.2
0.20	0.146	-134	4.321	-123	0.001	133	0.648	-85	65.8	12.7
0.40	0.103	-164	5.421	-177	0.002	97	0.384	-132	38.9	14.7
0.60	0.074	-178	5.860	151	0.003	88	0.224	-157	26.7	15.4
0.80	0.047	171	6.068	119	0.006	64	0.182	-126	13.3	15.7
1.00	0.013	125	5.176	92	0.008	38	0.338	-152	10.7	14.3
1.50	0.131	-68	4.863	53	0.006	0	0.103	127	16.7	13.7
2.00	0.230	-91	4.579	5	0.006	-16	0.074	-96	17.2	13.2
2.50	0.310	-113	4.179	-40	0.007	-31	0.161	-120	15.1	12.4
3.00	0.361	-132	3.879	-81	0.008	-45	0.189	-137	13.6	11.8
3.50	0.415	-150	3.749	-120	0.009	-60	0.180	-144	11.9	11.5
4.00	0.437	-173	3.845	-159	0.010	-74	0.177	-142	10.2	11.7
4.50	0.433	165	3.946	158	0.012	-89	0.207	-136	8.2	11.9
5.00	0.385	129	4.104	114	0.014	-110	0.282	-141	6.7	12.3
5.50	0.321	87	4.233	67	0.016	-134	0.364	-160	5.7	12.5
6.00	0.298	40	4.354	14	0.015	-164	0.357	167	6.0	12.8
6.50	0.382	-4	3.848	-35	0.015	-171	0.294	143	6.7	11.7
7.00	0.475	-36	3.553	-80	0.015	177	0.251	104	6.7	11.0
7.50	0.548	-57	3.334	-125	0.017	164	0.222	51	5.8	10.5
8.00	0.554	-73	3.290	-173	0.022	153	0.216	-1	4.5	10.3
8.50	0.460	-76	3.530	132	0.032	141	0.175	-21	3.4	11.0
9.00	0.585	-57	3.178	70	0.047	116	0.269	9	2.2	10.0
9.50	0.771	-71	1.665	9	0.057	83	0.512	-23	2.0	4.4
10.00	0.769	-82	0.871	-28	0.086	53	0.558	-50	2.3	-1.2

OUTLINE DIMENSIONS (Units in mm)

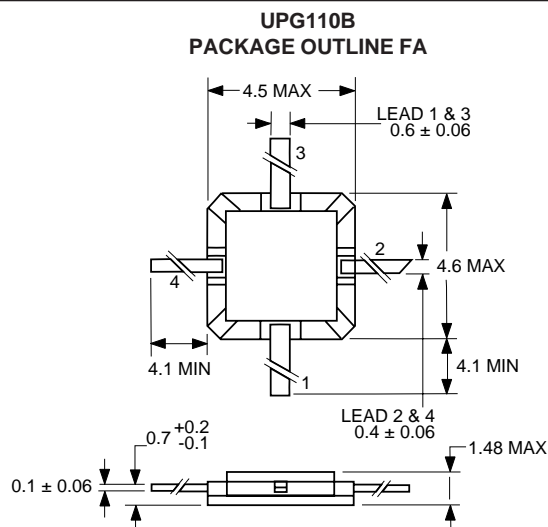

- 1. VDD
 - 2. In
 - 3. Non Connection
 - 4. Out
- Case: GND

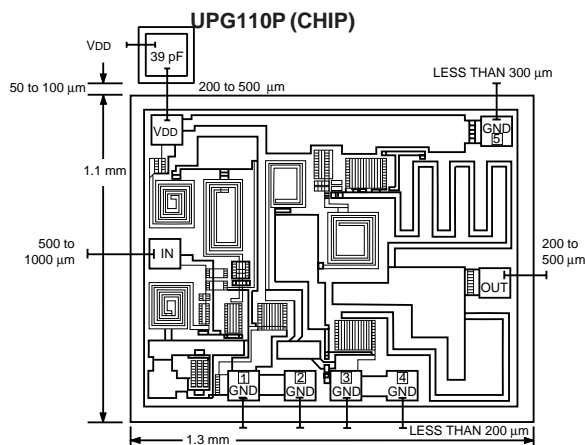

Bonding Pad Size: 200 µm x 200 µm
RECOMMENDED CHIP ASSEMBLY CONDITIONS

DIE ATTACHMENT

Atmosphere: N2 gas
 Temperature: 320 ± 5°C
 AuSn Preform: UPG100P, 101P, 103P 0.5 x 0.5 x 0.05 (mm), 1 pc
 UPG102P 1.2 x 1.2 x 0.05 (mm), 1 pc
 *The hard solder such as AuSi or AuGe which has higher melting point than AuSn should not be used.
 Base Material: CuW, Cu, KV (Other material should not be used)
 Epoxy Die Attach is not recommended.

BONDING

Machine: TCB (USB is not recommended)
 Wire: 30 µm diameter Au wire
 Temperature: 260 ± 10°C
 Strength: 44 ± 5g
 Atmosphere: N2 gas

EXCLUSIVE NORTH AMERICAN AGENT FOR **NEC** RF, MICROWAVE & OPTOELECTRONIC SEMICONDUCTORS

CEL CALIFORNIA EASTERN LABORATORIES • Headquarters • 4590 Patrick Henry Drive • Santa Clara, CA 95054-1817 • (408) 988-3500 • Telex 34-6393 • FAX (408) 988-0279

24-Hour Fax-On-Demand: 800-390-3232 (U.S. and Canada only) • Internet: <http://WWW.CEL.COM>

DATA SUBJECT TO CHANGE WITHOUT NOTICE

PRINTED IN USA ON RECYCLED PAPER -10/97