

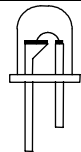

32 PATTERN  
VISION PERSISTENCE

闪烁图案 IC

LED FLASH	
M1170-1	

FEATURES 功能叙述

- 1 KEY 6 LED 32 patterns.
- OPT : ON/OFF, LH, Sequence.

MODE	OPT
ON/OFF	VSS
LH	X
SEQ	VDD

APPLICATION 产品应用

- Blinking LED, Functions indicator, Xmas decoration.

ELECTRICAL CHARACTERISTICS 电气规格

( @V<sub>DD</sub>=3V unless otherwise specified )

Characteristics	Sym.	Min.	Typ.	Max.	Unit	REMARKS
工作电压 Operating Voltage	V <sub>DD</sub>	2	3	5	V	
工作电流 Operating Current	I <sub>OP</sub>	96	120	144	μ A	
静态电流 Quiescent Current	I <sub>SB</sub>	—	1	5	μ A	
推动电流 Driving Current	I <sub>OL</sub>	4	—	—	mA	@ V <sub>DS</sub> =1.2V
工作温度 Operating Temperature	Temp.	0	25	60	°C	

APPLICATION DIAGRAM 参考电路图

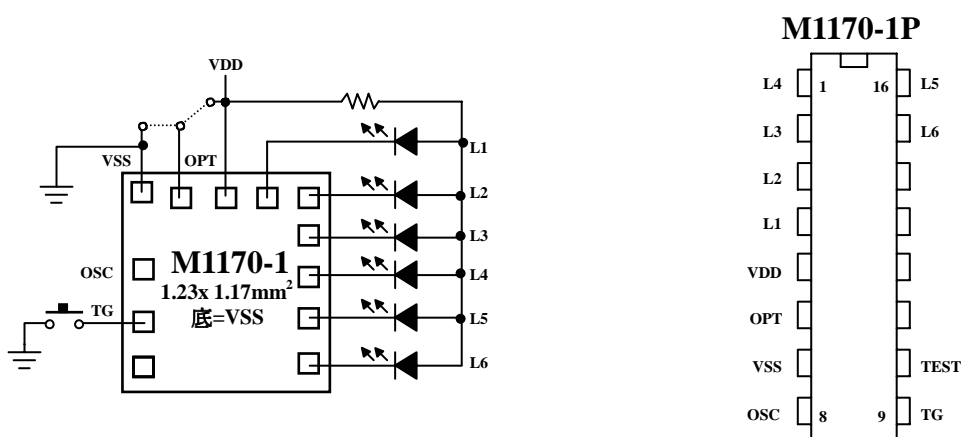

\*All specs and applications shown above subject to change without prior notice.  
( 以上电路及规格仅供参考,本公司得径行修正 )



32 PATTERN

VISION PERSISTENCE

闪烁图案 IC

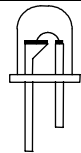
LED FLASH	
M1170-1	

**TIMING DIAGRAM (DEBOUNCE TIME—1MS)**

**1. ON/OFF (OPT=VSS)**

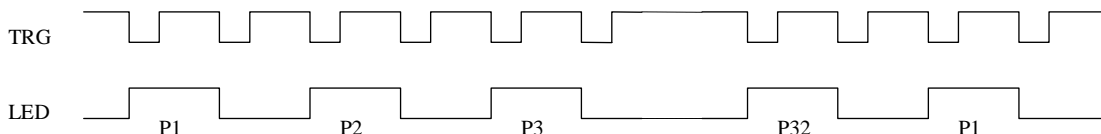

**2. LH (OPT=X)**

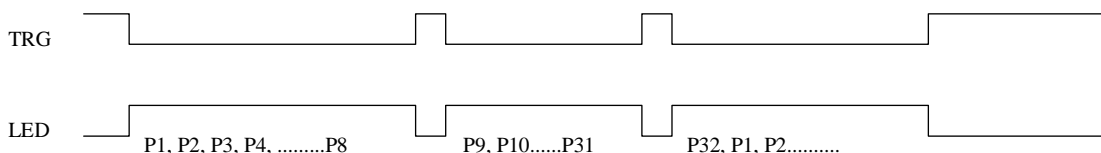

**3. SWQ (OPT=VDD)**

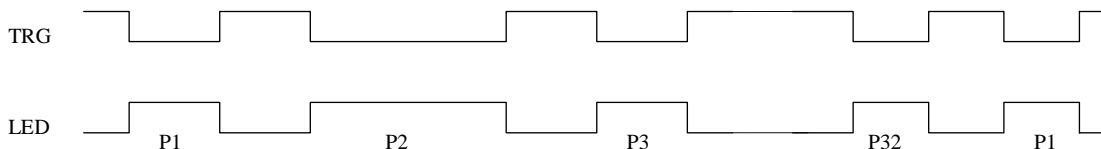



32 PATTERN  
VISION PERSISTENCE

闪烁图案 IC

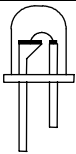
LED FLASH	
M1170-1	

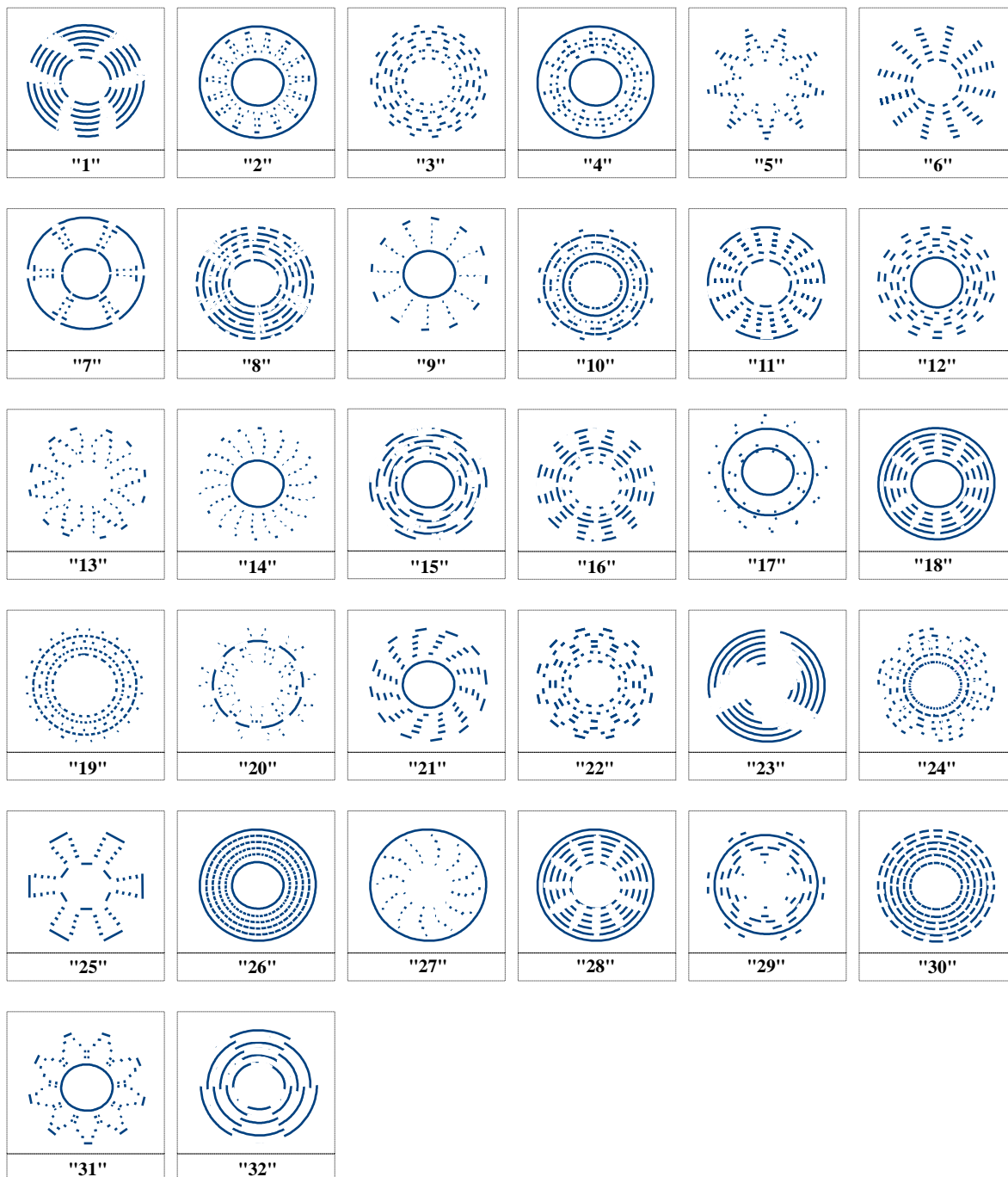



32 PATTERN

VISION PERSISTENCE

闪烁图案 IC

LED FLASH

M1170-1

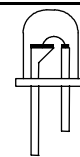

**PAD ASSIGNMENT & POSITION**

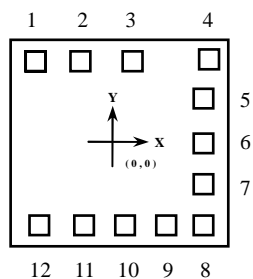

UNIT : um

No.	NAME	X	Y
1	TEST	408.4	376.7
2	TG	-191.1	376.7
3	OSC	76.9	376.7
4	VSS	466.8	426.6
5	OPT	416.9	246.6
6	VDD	419.9	29.3
7	L1	416.9	-177.4
8	L2	416.9	-384.1
9	L3	238.4	-384.1
10	L4	31.7	-384.1
11	L5	-175	-384.1
12	L6	-381.7	-384.1

\* CHIP SIZE ~ 1.23 x 1.17 mm<sup>2</sup>

\* IC substrate should be connected to VSS in PCB (PCB 上 IC 必须接 VSS)