

Document Title

512K x16 bit 2.5V Super Low Power Full CMOS slow SRAM

Revision History

<u>Revision No</u>	<u>History</u>	<u>Draft Date</u>	<u>Remark</u>
00	Initial Draft	Apr.10.2001	Preliminary
01	Change Logo - Hyundai → Hynix	Apr.28.2001	
02	Change DC Parameter - Isb1(LL) : 30uA → 25uA - Isb1(Typ) : 8uA → 1uA - Icc1(1us) : 5mA → 4mA Change Data Retention - IccDR(LL) : 25uA → 15uA Change AC Parameter - tOE : 40ns → 35ns@70ns	Jan.28.2002	

DESCRIPTION

The HY62LF16806A is a high speed, super low power and 8Mbit full CMOS SRAM organized as 524,288 words by 16bits. The HY62LF16806A uses high performance full CMOS process technology and is designed for high speed and low power circuit technology. It is particularly well-suited for the high density low power system application. This device has a data retention mode that guarantees data to remain valid at a minimum power supply voltage of 1.2V.

FEATURES

- Fully static operation and Tri-state output
- TTL compatible inputs and outputs
- Battery backup(LL/SL-part)
 - 1.2V(min) data retention
- Standard pin configuration
 - 48-uBGA

Product No.	Voltage (V)	Speed (ns)	Operation Current/Icc(mA)	Standby Current(uA)		Temperature (°C)
				LL	SL	
HY62LF16806A-C	2.3~2.7	70/85/100	3	30	8	0~70
HY62LF16806A-I	2.3~2.7	70/85/100	3	30	8	-45~85

Note 1. C : Commercial, I : Industrial
 2. Current value is max.

PIN CONNECTION (Top View)

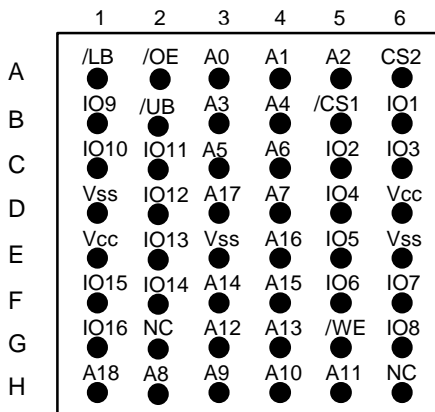

BLOCK DIAGRAM

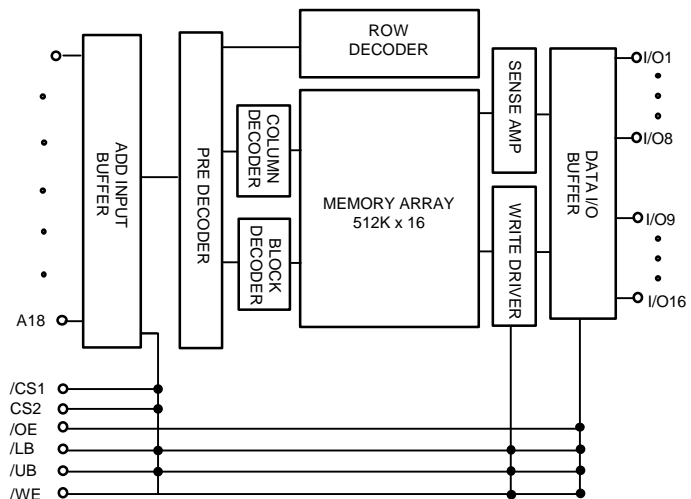

PIN DESCRIPTION

Pin Name	Pin Function	Pin Name	Pin Function
/CS1, CS2	Chip Select	I/O1~I/O16	Data Inputs / Outputs
/WE	Write Enable	A0~A18	Address Inputs
/OE	Output Enable	Vcc	Power(2.3V~2.7V)
/LB	Lower Byte Control(I/O1~I/O8)	Vss	Ground
/UB	Upper Byte Control(I/O9~I/O16)	NC	No Connection

ORDERING INFORMATION

Part No.	Speed	Power	Package	Temp.
HY62LF16806A-DMC	70/85/100	LL-part	uBGA	C
HY62LF16806A-SMC	70/85/100	SL-part	uBGA	C
HY62LF16806A-DMI	70/85/100	LL-part	uBGA	I
HY62LF16806A-SMI	70/85/100	SL-part	uBGA	I

Note 1. C : Commercial, I : Industrial

ABSOLUTE MAXIMUM RATINGS (1)

Symbol	Parameter	Rating	Unit	Remark
V _{IN} , V _{OUT}	Input/Output Voltage	-0.2 to 3.6	V	
V _{CC}	Power Supply	-0.2 to 4.6	V	
T _A	Operating Temperature	0 to 70	°C	HY62LF16806A-C
		-40 to 85	°C	HY62LF16806A-I
T _{STG}	Storage Temperature	-55 to 150	°C	
P _D	Power Dissipation	1.0	W	
T _{SOLDER}	Ball Soldering Temperature & Time	260 • 10	°C • sec	

Note

- Stresses greater than those listed under ABSOLUTE MAXIMUM RATINGS may cause permanent damage to the device. This is stress rating only and the functional operation of the device under these or any other conditions above those indicated in the operation of this specification is not implied. Exposure to the absolute maximum rating conditions for extended period may affect reliability.

TRUTH TABLE

/CS1	CS2	/WE	/OE	/LB	/UB	Mode	I/O Pin		Power
							I/O1~I/O8	I/O9~I/O16	
H	X	X	X	X	X	Deselected	Hi-Z	Hi-Z	Standby
X	L	X	X	X	X		Hi-Z	Hi-Z	
X	X	X	X	H	H		Hi-Z	Hi-Z	
L	H	H	H	L	X	Output Disabled	Hi-Z	Hi-Z	Active
L	H	H	H	X	L		Hi-Z	Hi-Z	
L	H	H	L	L	H	Read	DOUT	Hi-Z	Active
				H	L		Hi-Z	DOUT	
				L	L		DOUT	DOUT	
L	H	L	X	L	H	Write	DIN	Hi-Z	Active
				H	L		Hi-Z	DIN	
				L	L		DIN	DIN	

Note:

- H=V_{IH}, L=V_{IL}, X=don't care(V_{IH} or V_{IL})
- UB, LB(Upper, Lower Byte enable)
 These active LOW inputs allow individual bytes to be written or read.
 When LB is LOW, data is written or read to the lower byte, I/O1 -I/O8.
 When UB is LOW, data is written or read to the upper byte, I/O9 -I/O16.

RECOMMENDED DC OPERATING CONDITION

Symbol	Parameter	Min.	Typ.	Max.	Unit
Vcc	Supply Voltage	2.3	2.5	2.7	V
Vss	Ground	0	0	0	V
VIH	Input High Voltage	2.0	-	Vcc+0.3	V
VIL	Input Low Voltage	-0.3(1)	-	0.6	V

Note : 1. VIL = -1.5V for pulse width less than 30ns

DC ELECTRICAL CHARACTERISTICS

Vcc = 2.3V~2.7V, TA = 0°C to 70°C / -40°C to 85°C

Sym	Parameter	Test Condition	Min	Typ ¹	Max	Unit
ILI	Input Leakage Current	Vss ≤ VIN ≤ Vcc	-1	-	1	uA
ILO	Output Leakage Current	Vss ≤ VOUT ≤ Vcc, /CS1 = VIH or CS2=VIL or /OE = VIH or /WE = VIL or /UB = VIH, /LB = VIH	-1	-	1	uA
Icc	Operating Power Supply Current	/CS1 = VIL, CS2=VIH, VIN = VIH or VIL, Ii/O = 0mA			3	mA
Icc1	Average Operating Current	/CS1 = VIL, CS2 = VIH, VIN = VIH or VIL, Cycle Time = Min, 100% Duty, Ii/O = 0mA			30	mA
		/CS1 ≤ 0.2V, CS2 ≥ Vcc-0.2V, VIN ≤ 0.2V or VIN ≥ Vcc-0.2V, Cycle Time = 1us, 100% Duty, Ii/O = 0mA			4	mA
ISB	Standby Current (TTL Input)	/CS1 = VIH or CS2 = VIL or /UB, /LB = VIH VIN = VIH or VIL			0.3	mA
ISB1	Standby Current (CMOS Input)	/CS1 ≥ Vcc - 0.2V or CS2 ≤ Vss + 0.2V or /UB, /LB ≥ Vcc - 0.2V VIN ≥ Vcc - 0.2V or VIN ≤ Vss + 0.2V	SL	-	8	uA
			LL	1	25	uA
VOL	Output Low	IOL = 0.5mA	-	-	0.4	V
VOH	Output High	IOH = -0.5mA	2.0	-	-	V

Note :

1. Typical values are at Vcc = 2.5V, TA = 25°C
2. Typical values are not 100% tested

CAPACITANCE

(Temp = 25°C, f = 1.0MHz)

Symbol	Parameter	Condition	Max.	Unit
CIN	Input Capacitance (Add, /CS1,CS2,/LB,/UB, /WE, /OE)	VIN = 0V	8	pF
COU	Output Capacitance (I/O)	Vi/O = 0V	10	pF

Note : These parameters are sampled and not 100% tested

AC CHARACTERISTICS

V_{CC} = 2.3V~2.7V, T_A = 0°C to 70°C/ -40°C to 85°C, unless otherwise specified

#	Symbol	Parameter	-70		-85		-10		Unit
			Min.	Max.	Min.	Max.	Min	Max.	
READ CYCLE									
1	t _{RC}	Read Cycle Time	70	-	85	-	100	-	ns
2	t _{AA}	Address Access Time	-	70	-	85	-	100	ns
3	t _{ACS}	Chip Select Access Time	-	70	-	85	-	100	ns
4	t _{OE}	Output Enable to Output Valid	-	35	-	45	-	50	ns
5	t _{BA}	/LB, /UB Access Time	-	70	-	85	-	100	ns
6	t _{CLZ}	Chip Select to Output in Low Z	10	-	10	-	10	-	ns
7	t _{OLZ}	Output Enable to Output in Low Z	5	-	5	-	5	-	ns
8	t _{BLZ}	/LB, /UB Enable to Output in Low Z	10	-	10	-	10	-	ns
9	t _{CHZ}	Chip Deselection to Output in High Z	0	30	0	30	0	30	ns
10	t _{OHZ}	Out Disable to Output in High Z	0	30	0	30	0	30	ns
11	t _{BHZ}	/LB, /UB Disable to Output in High Z	0	30	0	30	0	30	ns
12	t _{OH}	Output Hold from Address Change	10	-	10	-	15	-	ns
WRITE CYCLE									
13	t _{WC}	Write Cycle Time	70	-	85	-	100	-	ns
14	t _{CW}	Chip Selection to End of Write	60	-	70	-	80	-	ns
15	t _{AW}	Address Valid to End of Write	60	-	70	-	80	-	ns
16	t _{BW}	/LB, /UB Valid to End of Write	60	-	70	-	80	-	ns
17	t _{AS}	Address Set-up Time	0	-	0	-	0	-	ns
18	t _{WP}	Write Pulse Width	50	-	55	-	75	-	ns
19	t _{WR}	Write Recovery Time	0	-	0	-	0	-	ns
20	t _{WHZ}	Write to Output in High Z	0	25	0	30	0	35	ns
21	t _{DW}	Data to Write Time Overlap	30	-	35	-	45	-	ns
22	t _{DH}	Data Hold from Write Time	0	-	0	-	0	-	ns
23	t _{OW}	Output Active from End of Write	5	-	5	-	10	-	ns

AC TEST CONDITIONS

T_A = 0°C to 70°C(Commercial)/ -40°C to 85°C, unless otherwise specified

PARAMETER		Value
Input Pulse Level		0.4V to 2.2V
Input Rise and Fall Time		5ns
Input and Output Timing Reference Level		1.1V
Output Load	t _{CLZ} , t _{OLZ} , t _{BLZ} , t _{CHZ} , t _{OHZ} , t _{BHZ} , t _{WHZ} , t _{OW}	CL = 5pF + 1TTL Load
	Other	CL = 30pF + 1TTL Load

AC TEST LOADS

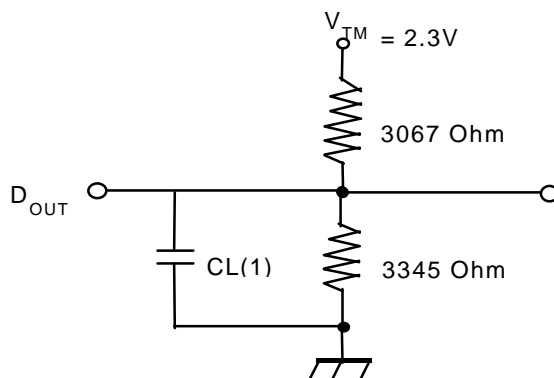

Note

1. Including jig and scope capacitance

TIMING DIAGRAM

READ CYCLE 1 (Note 1,4)

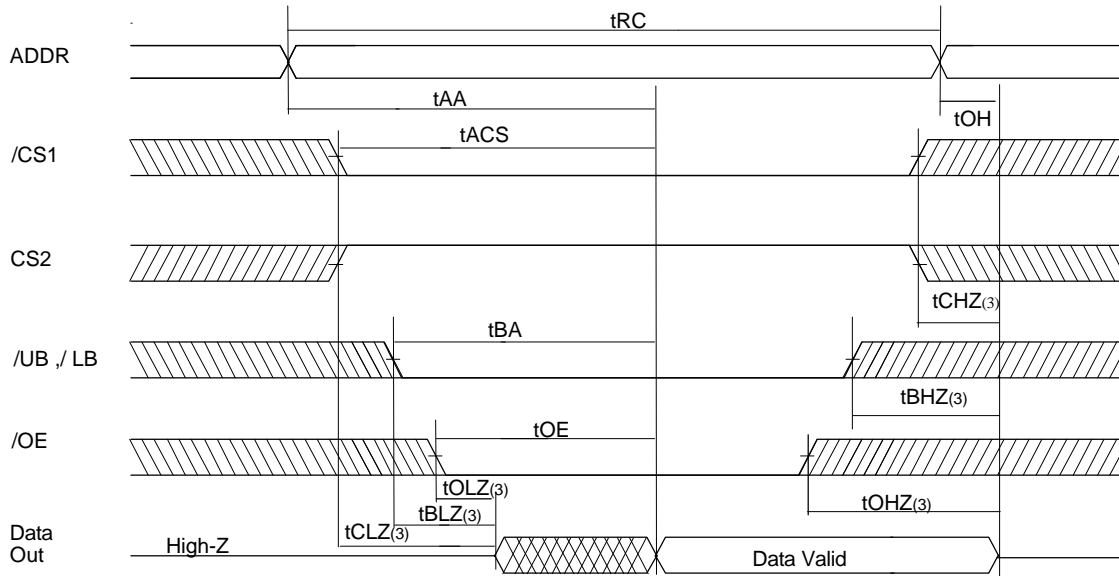

READ CYCLE 2 (Note 1,2,4)

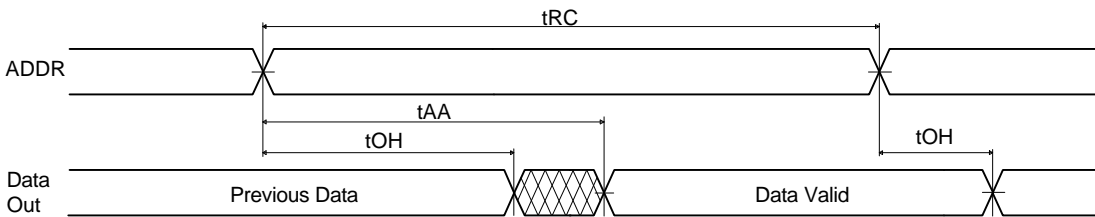

READ CYCLE 3 (Note 1,2,4)

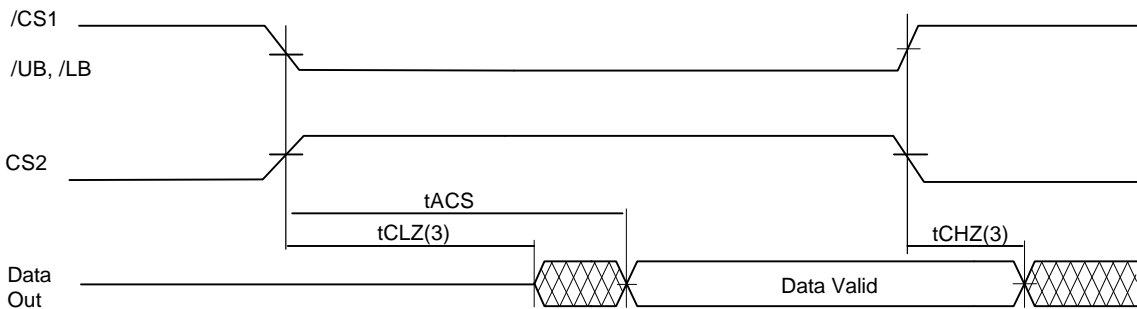

Notes:

1. Read Cycle occurs whenever a high on the /WE and /OE is low, while /UB and/or /LB and /CS1 and CS2 are in active status.
2. /OE = V_{IL}
3. Transition is measured ± 200mV from steady state voltage.
This parameter is sampled and not 100% tested.
4. /CS1 in high for the standby, low for active
CS2 in low for the standby, high for active. /UB and /LB in high for the standby, low for active

WRITE CYCLE 1 (1,4,8) (/WE Controlled)

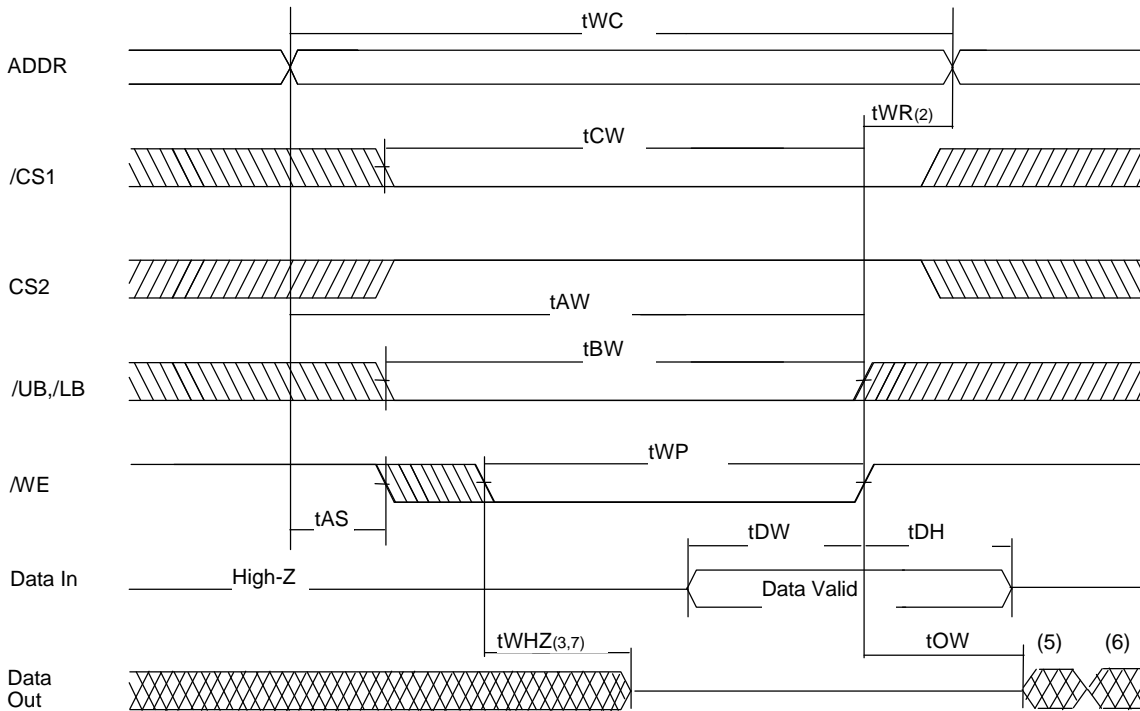

WRITE CYCLE 2 (Note 1,4,8) (/CS1, CS2 Controlled)

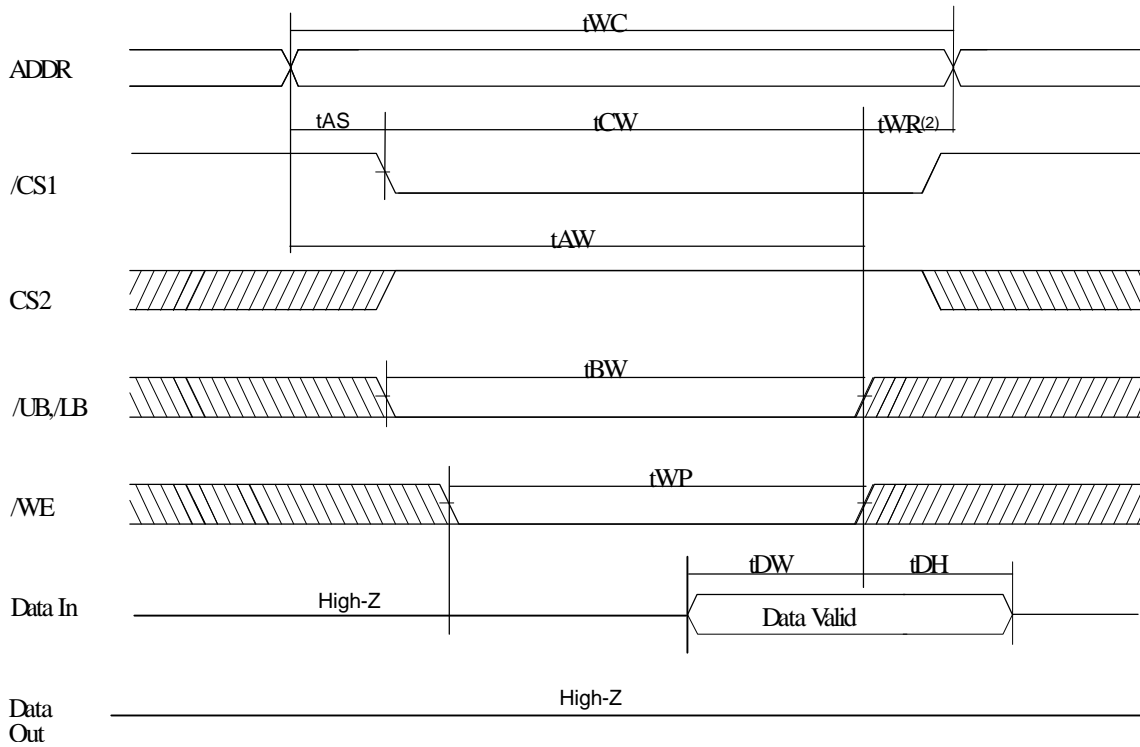

Notes:

1. A write occurs whenever a low on the /WE while /UB and/or /LB and /CS1 and CS2 are in active state.
2. tWR is measured from the earlier of /CS1, /LB, /UB, or /WE going high or CS2 going low to the end of write cycle.
3. During this period, I/O pins are in the output state so that the input signals of opposite phase to the output must not be applied.
4. If the /CS1, /LB and /UB low transition and CS2 high transition occur simultaneously with the /WE low transition or after the /WE transition, outputs remain in a high impedance state.
5. Q(data out) is the same phase with the write data of this write cycle.
6. Q(data out) is the read data of the next address.
7. Transition is measured $\pm 200\text{mV}$ from steady state. This parameter is sampled and not 100% tested.
8. /CS1 in high for the standby, low for active
CS2 in low for the standby, high for active.
/UB and /LB in high for the standby, low for active

DATA RETENTION ELECTRIC CHARACTERISTIC

TA= 0°C to 70°C(Commercial)/ -40°C to 85°C

Symbol	Parameter	Test Condition	Min	Typ ¹	Max	Unit	
VDR	Vcc for Data Retention	/CS1 \geq Vcc - 0.2V or CS2 \leq Vss + 0.2V or /UB, /LB \geq Vcc - 0.2V, VIN \geq Vcc - 0.2V or VIN \leq Vss + 0.2V	1.2	-	2.7	V	
Iccdr	Data Retention Current	Vcc=1.5V, /CS1 \geq Vcc - 0.2V or CS2 \leq Vss + 0.2V or /UB, /LB \geq Vcc - 0.2V VIN \geq Vcc - 0.2V or VIN \leq Vss + 0.2V	SL	-	-	8	uA
			LL	-	-	15	uA
tCDR	Chip Deselect to Data Retention Time	See Data Retention Timing Diagram	0	-	-	ns	
tR	Operating Recovery Time		tRC	-	-	ns	

Notes:

1. Typical values are under the condition of TA = 25°C .
2. tRC is read cycle time.

DATA RETENTION TIMING DIAGRAM 1

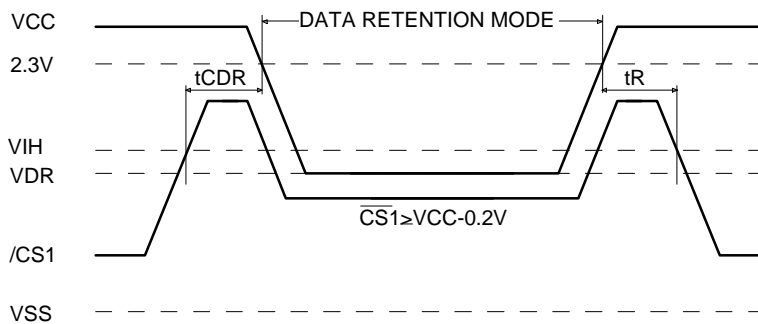

DATA RETENTION TIMING DIAGRAM 2

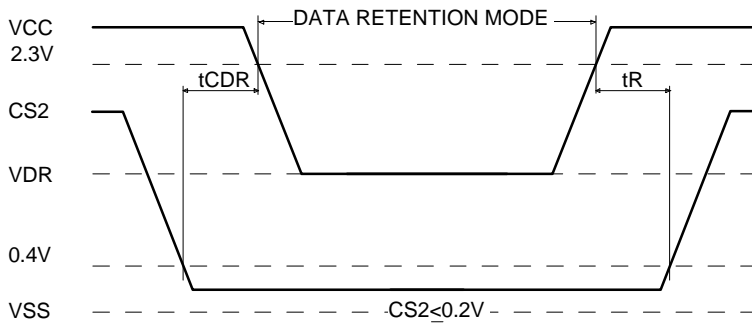

PACKAGE INFORMATION

48ball Micro Ball Grid Array Package(M)

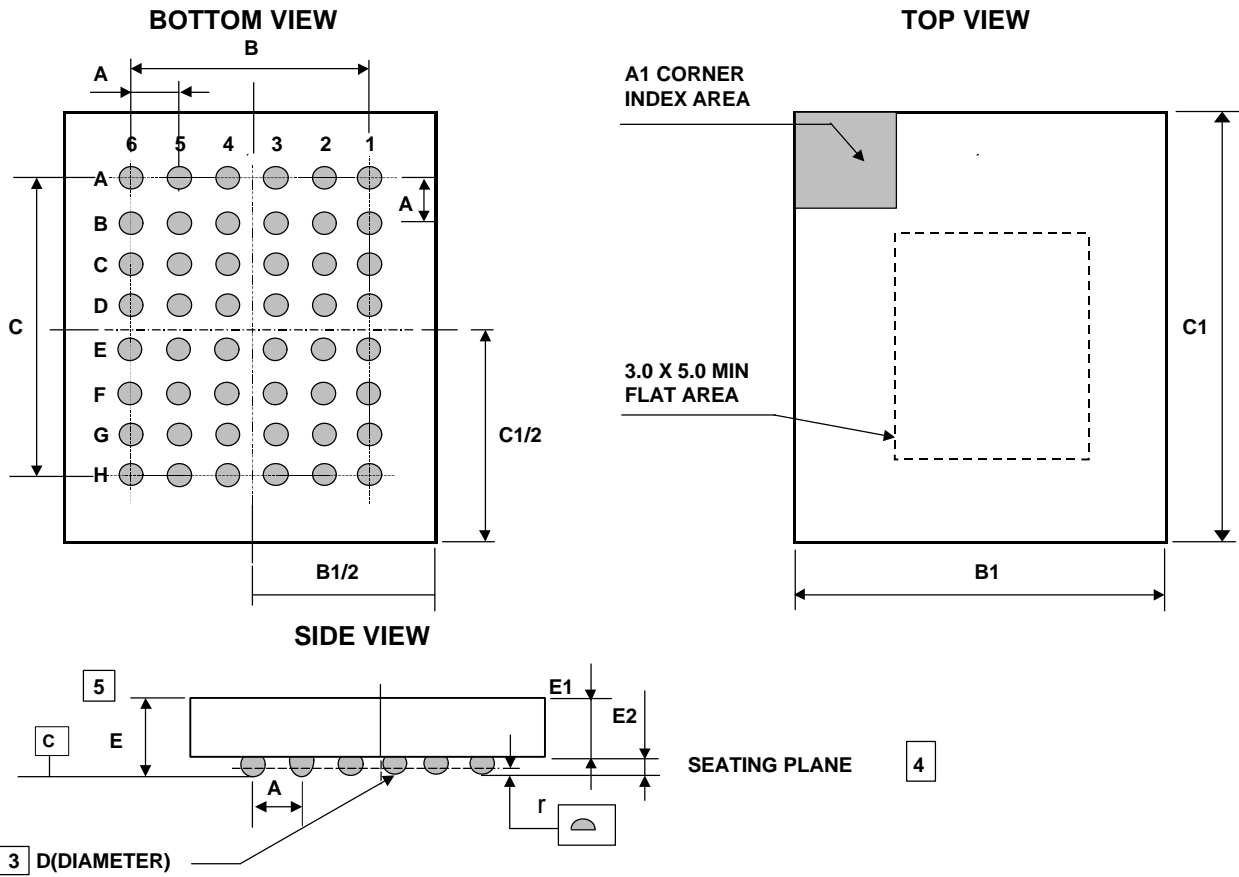

Symbol	Min.	Typ.	Max.
A	-	0.75	-
B	-	3.75	-
B1	-	7.4	-
C	-	5.25	-
C1	-	8.5	-
D	0.3	0.35	0.4
E	0.85	0.9	0.95
E1	0.6	0.65	0.7
E2	0.2	0.25	0.3
r	-	-	0.08

Note

1. DIMENSIONING AND TOLERANCING PER ASME Y14. 5M-1994.
2. ALL DIMENSIONS ARE MILLIMETERS.
3. DIMENSION "D" IS MEASURED AT THE MAXIMUM SOLDER BALL DIAMETER IN A PLANE PARALLEL TO DATUM C.
4. PRIMARY DATUM C(SEATING PLANE) IS DEFINED BY THE CROWN OF THE SOLDER BALLS.
5. THIS IS A CONTROLLING DIMENSION.

MARKING INSTRUCTION

Package	Marking Example
uBGA	

Index

• HYLF6806A	: Part Name
• c	: Power Consumption - D : Low Low Power - S : Super Low Power
• ss	: Speed - 55 : 55ns - 70 : 70ns - 85 : 85ns
• t	: Temperature - C : Commercial (-0 ~ 70 C) - I : Industrial (-40 ~ 85 C)
• y	: Year (ex : 0 = year 2000, 1= year2001)
• ww	: Work Week (ex : 12 = work week 12)
• p	: Process Code
• xxxxx	: Lot No.
• KOR	: Origin Country
Note	
- Capital Letter	: Fixed Item
- Small Letter	: Non-fixed Item