

GP1A35RV

High Sensing Accuracy OPIC Photointerrupter with Encoder Functions

■ Features

1. 2-phase (A, B) digital output
2. High sensing accuracy
(Disk slit pitch: 0.22mm, Moire stripe application)
3. TTL compatible output
4. Compact and light

■ Applications

1. Copiers
2. Electronic typewriters, printers
3. Numerical control machines

■ Outline Dimensions

(Unit : mm)

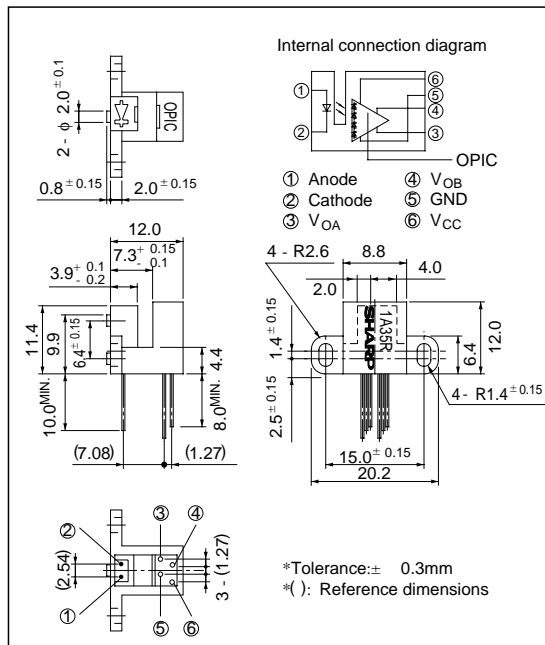

** OPIC™ (Optical IC) is a trademark of the SHARP Corporation.
An OPIC consists of a light-detecting element and signal-processing circuit integrated onto a single chip.

■ Absolute Maximum Ratings

(T_a= 25°C)

	Parameter	Symbol	Rating	Unit
Input	Forward current	I _F	65	mA
	*1 Peak forward current	I _{FM}	1	A
	Reverse voltage	V _R	6	V
	Power dissipation	P	100	mW
Output	Supply voltage	V _{CC}	7	V
	Low level output current	I _{OL}	20	mA
	Power dissipation	P _O	250	mW
Operating temperature		T _{opr}	0 to + 70	°C
Storage temperature		T _{stg}	- 40 to + 80	°C
*2 Soldering temperature		T _{sol}	260	°C

*1 Pulse width ≤ 100 μs, Duty ratio = 0.01

*2 For 5 seconds

Electro-optical Characteristics

(T_a= 25°C)

Parameter		Symbol	Conditions	MIN.	TYP.	MAX.	Unit		
Input	Forward voltage	V _F	I _F = 30mA	-	1.2	1.5	V		
	Reverse current	I _R	V _R = 3V	-	-	10	μ A		
Output	Output voltage	Phase A	High level	V _{AH}	V _{CC} = 5V, I _F = 30mA	2.4	4.9	-	V
			Low level	V _{AL}	I _{OL} = 8mA, I _F = 30mA, V _{CC} = 5V	-	0.1	0.4	
		Phase B	High level	V _{BH}	V _{CC} = 5V, I _F = 30mA	2.4	4.9	-	
			Low level	V _{BL}	I _{OL} = 8mA, I _F = 30mA, V _{CC} = 5V	-	0.1	0.4	
	Dissipation current		I _{CC}	^{*3} V _{CC} = 5V, I _F = 30mA	-	5	20	mA	
Transfer characteristics	Duty ratio	^{*4} Δ _A	I _F = 30mA ^{*6} f= 12kHz	30	50	70	%		
		^{*4} Δ _B							
	Phase difference	^{*5} θ _{AB1}	V _{CC} = 5V	50	90	130	deg.		
	Response speed	t _r	I _F = 30mA, V _{CC} = 5V	-	1.0	2.0	μ s		
t _f		^{*6} f= 12kHz		-	1.0	2.0			

*3 In the condition that output A and B are low level.

$$*4 \Delta_A = \frac{t_{AH}}{t_{AP}} \times 100, \Delta_B = \frac{t_{BH}}{t_{BP}} \times 100$$

$$*5 \theta_{AB1} = \frac{t_{AB1}}{t_{AP}} \times 360^\circ$$

*6 Measured under the condition shown in Measurement Conditions.

Output Waveforms

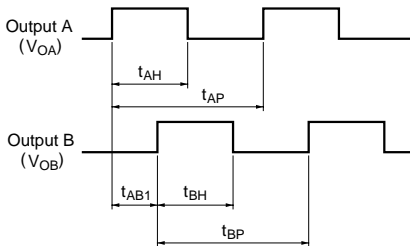

Rotational direction: Counterclockwise when seen from OPIC light detector

Fig. 1 Forward Current vs. Ambient Temperature

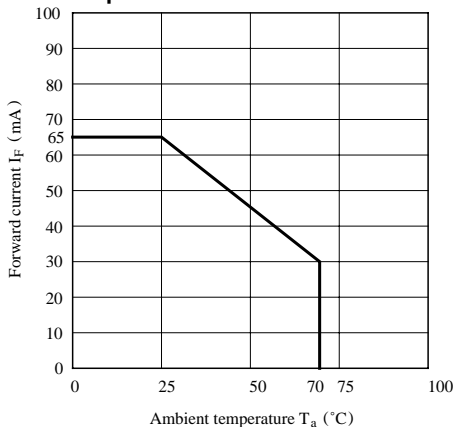

Fig. 2 Output Power Dissipation vs. Ambient Temperature

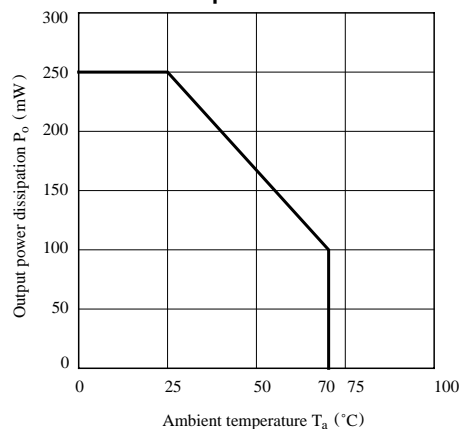

Fig. 3 Duty Ratio vs. Frequency

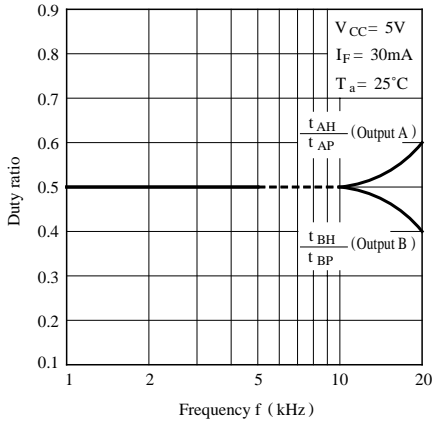

Fig. 4 Phase Difference vs. Frequency

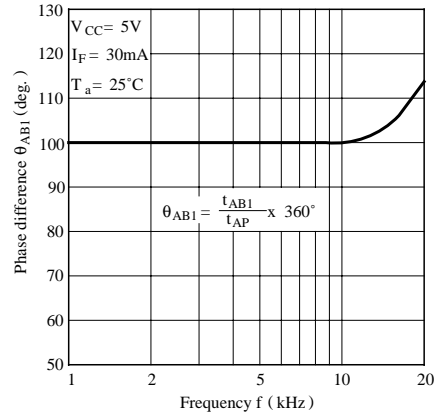

Fig. 5 Duty Ratio vs. Ambient Temperature

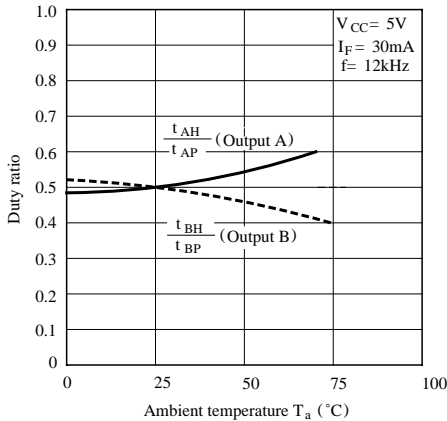

Fig. 6 Phase Difference vs. Ambient Temperature

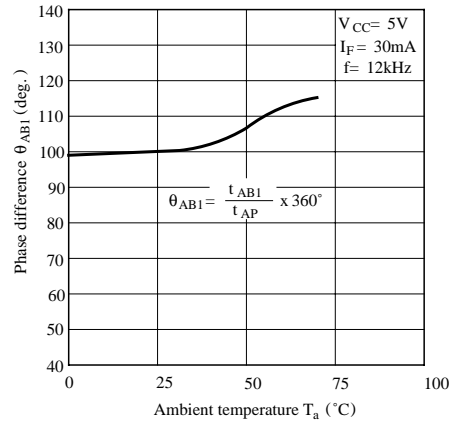

Fig. 7 Duty Ratio vs. Distance (Xdirection)

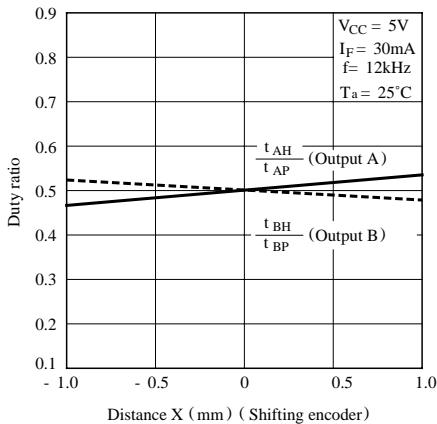

Fig. 8 Phase Difference vs. Distance (Xdirection)

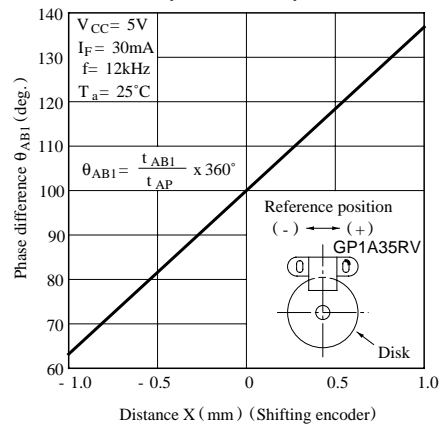

Fig. 9 Duty Ratio vs. Distance (Ydirection)

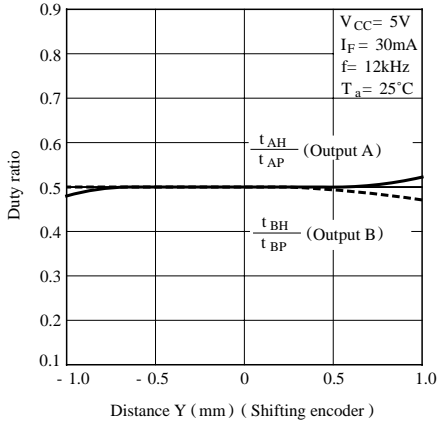

Fig.10 Phase Difference vs. Distance (Ydirection)

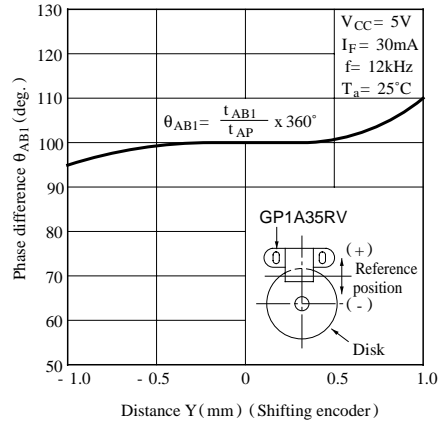

Fig.11 Duty Ratio vs. Distance (Zdirection)

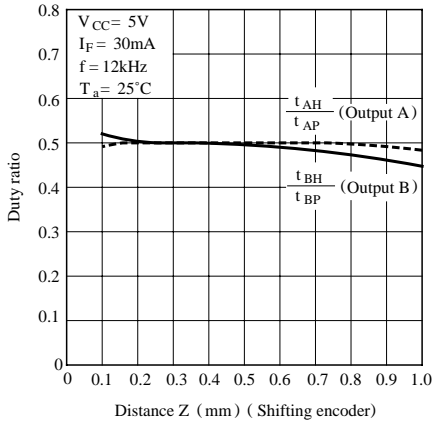
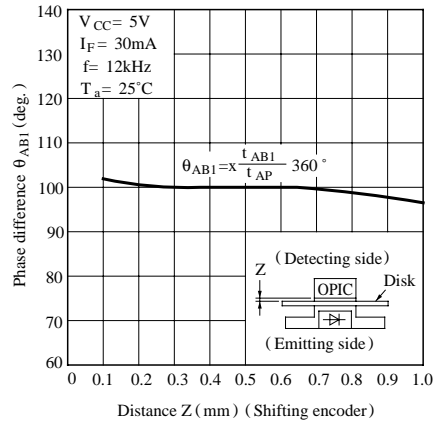
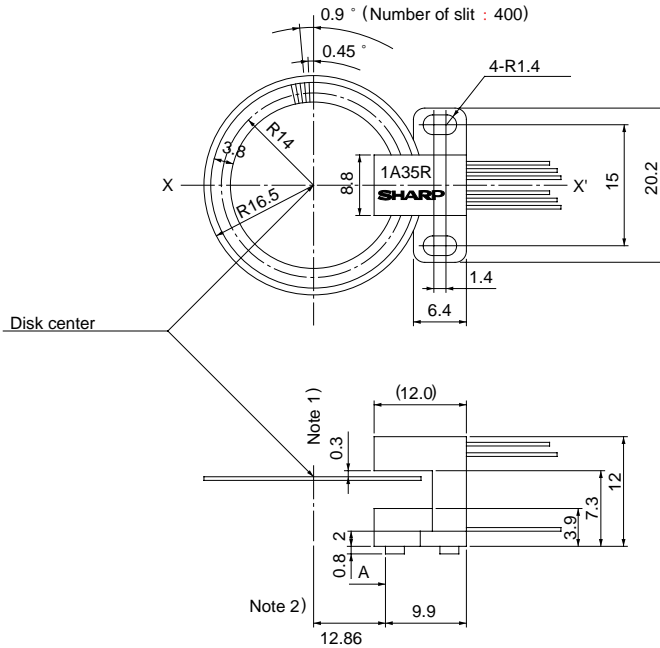

Fig.12 Phase Difference vs. Distance (Zdirection)



Measurement Conditions



- Note 1) Distance between disk surface and case surface in the detector side is 0.3mm.
 Note 2) Encoder positioning pin is positioned on X-X' axis.
 Distance between center of disk and portion A of positioning pin is 12.86mm.
 Note 3) Center of disk slit is R14.0.

■ Precautions for Use

- (1) This module is designed to be operated at $I_{F} = 30\text{mA TYP.}$
- (2) Fixing torque : MAX. $0.6\text{N} \cdot \text{m}$
- (3) In order to stabilize power supply line, connect a by-pass capacitor of more than $0.01 \mu\text{F}$ between V_{CC} and GND near the device.
- (4) As for other general cautions, refer to the chapter "Precautions for Use".

■ Application Circuit (Detection of Rotational Direction)

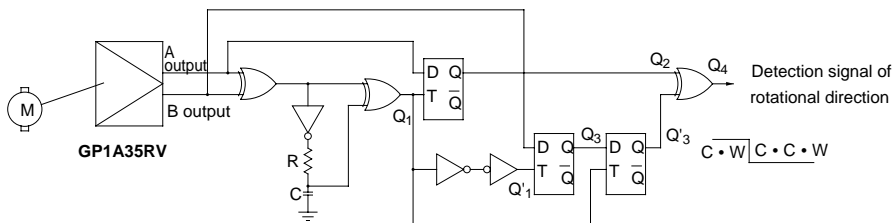

When gate delay causes pulse noise in Q4 output, apply the CR filter to remove pulse noise.