

# 10BASE-T NETWORK COMPONENTS

960062A

- Designed for use with Seeq 80C24-26 and 83C95-96 10Base-T PHY transceivers
- Single and dual port designs available with and without common mode chokes
- Conforms to IEEE 802.3 standards
- Through-hole and surface mount packaging
- 2000 Vrms isolation

## ELECTRICALS AT 25°C

Part No.	Turns Ratio (transmit)	Insertion Loss (dB) Max 1-10MHz	OCL (μH) Min	Return Loss (dB) Min 5-10MHz	Crosstalk (dB) Min 1MHz-10MHz	CM-CM Rej (dB) Min		Schematic	Package Style
						10-30MHz	100MHz		
A553-1084-01	2CT:1	-1.0	80	-18	-40	N/A	N/A	A	1
S553-1084-01	2CT:1	-1.0	80	-18	-40	N/A	N/A	A	2
S553-1084-05	2CT:1CT	-1.0	200	-18	-40	N/A	N/A	B	3
S553-1084-06	2CT:1	-1.0	80	-18	-40	-40	-30	C	2
S553-1084-11	2CT:1CT	-1.0	80	-18	-40	N/A	N/A	D	2
S553-1084-16	2CT:1CT	-1.0	80	-18	-40	-40	-30	E	2

## SCHEMATICS

A

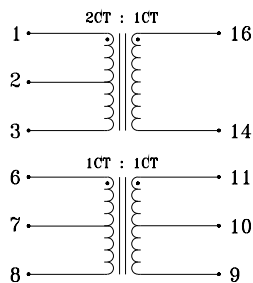

B

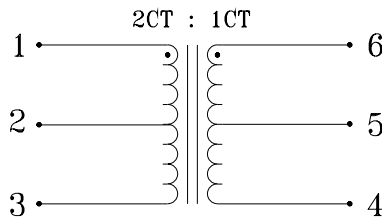

C

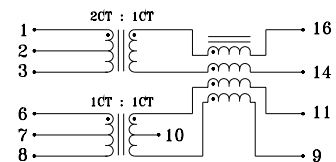

D

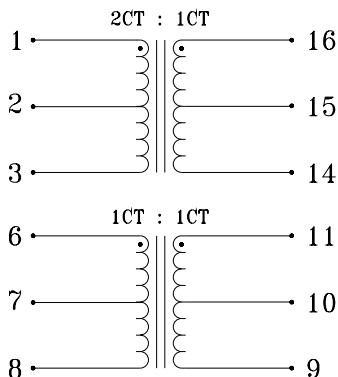

E

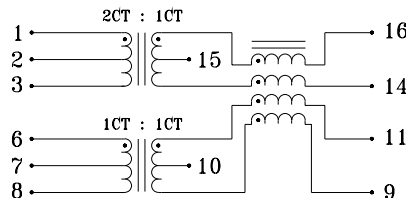

### Corporate Office

**Bel Fuse Inc.**  
 198 Van Vorst Street, Jersey City, NJ 07302-4496  
 Tel: 201-432-0463  
 Fax: 201-432-9542  
 E-Mail: [BelFuse@belfuse.com](mailto:BelFuse@belfuse.com)  
 Internet: <http://www.belfuse.com>

### Far East Office

**Bel Fuse Ltd.**  
 8F/8 Luk Hop Street  
 San Po Kong  
 Kowloon, Hong Kong  
 Tel: 852-2328-5515  
 Fax: 852-2352-3706

### European Office

**Bel Fuse Europe Ltd.**  
 Preston Technology Management Centre  
 Marsh Lane, Preston PR1 8UD  
 Lancashire, U.K.  
 Tel: 44-1772-556601  
 Fax: 44-1772-888366

## 10BASE-T NETWORK COMPONENTS

960062A

### MECHANICALS

1

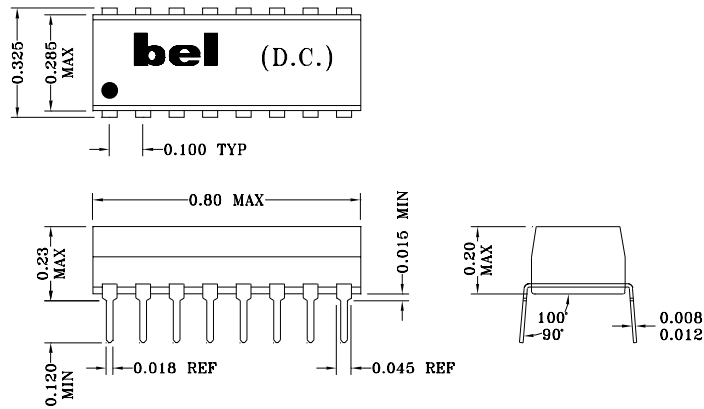

2

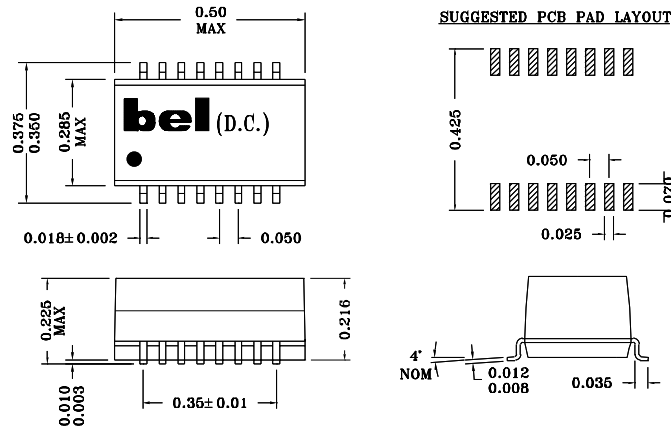

3

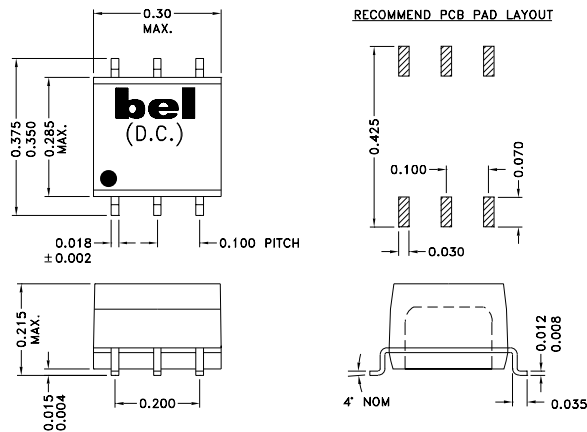

Specifications subject to change without notice.

# 10BASE-T NETWORK COMPONENTS

## APPLICATION CIRCUIT

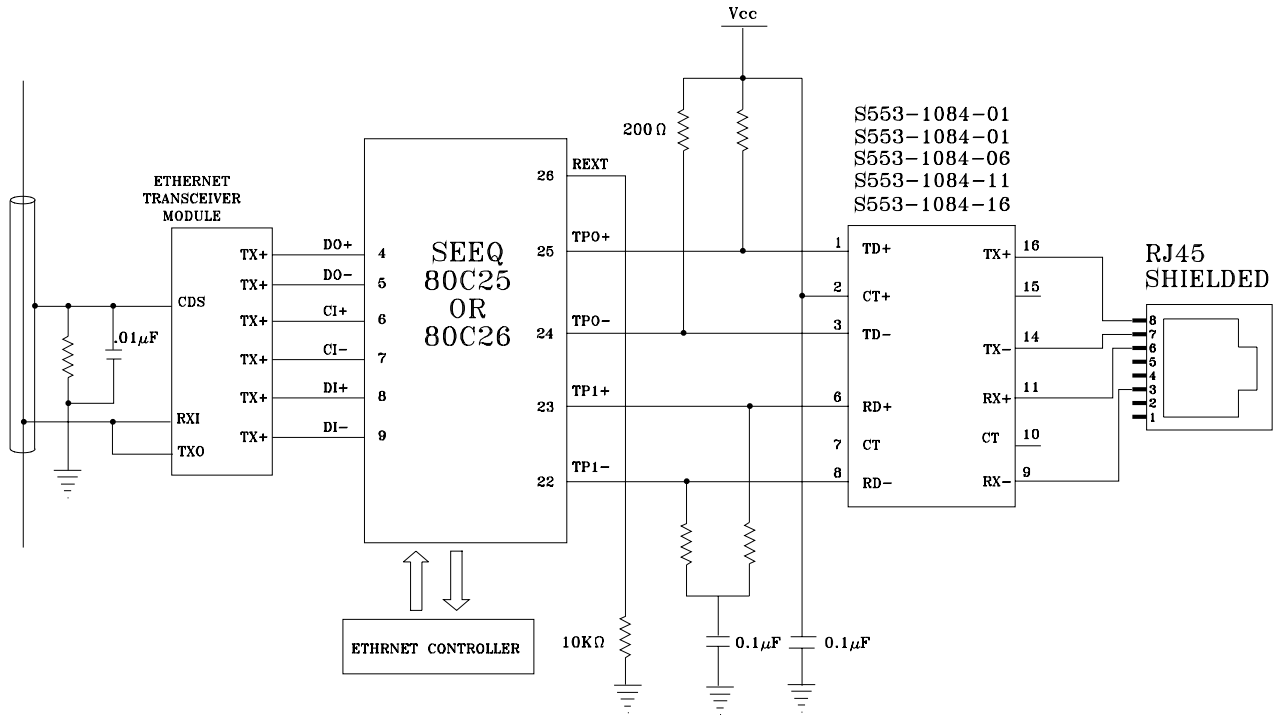

TYPICAL TP/COAX ADAPTER BOARD APPLICATION

Specifications subject to change without notice.



defining a degree of excellence

## 10BASE-T NETWORK COMPONENTS

960062A

### APPLICATION NOTES

---

- All receive transformers (except for S553-1084-05) have 1CT:1CT turns ratio.
- Multiple design options offered to optimize individual PCB layouts and grounding configurations. Consult Bel engineering for assistance in choosing the best solution.
- Bel's low profile, surface mount packaging is ideal for high speed pick and place machinery. Parts can be shipped on tape and reel for high speed placement. Construction processes have been implemented for thermal compatibility with high temperature IR reflow assembly processing. Post dipping of leads assist with PC board solderability. Each part is optically inspected to meet rigid coplanarity requirements.

---

#### *Corporate Office*

**Bel Fuse Inc.**

198 Van Vorst Street, Jersey City, NJ 07302-4496

Tel: 201-432-0463

Fax: 201-432-9542

E-Mail: [BelFuse@belfuse.com](mailto:BelFuse@belfuse.com)

Internet: <http://www.belfuse.com>

#### *Far East Office*

**Bel Fuse Ltd.**

8F/8 Luk Hop Street

San Po Kong

Kowloon, Hong Kong

Tel: 852-2328-5515

Fax: 852-2352-3706

#### *European Office*

**Bel Fuse Europe Ltd.**

Preston Technology Management Centre

Marsh Lane, Preston PR1 8UD

Lancashire, U.K.

Tel: 44-1772-556601

Fax: 44-1772-888366