

1050QN, 1052QN Series Non-Relampable Neon Indicator Light

DESCRIPTION AND FEATURES

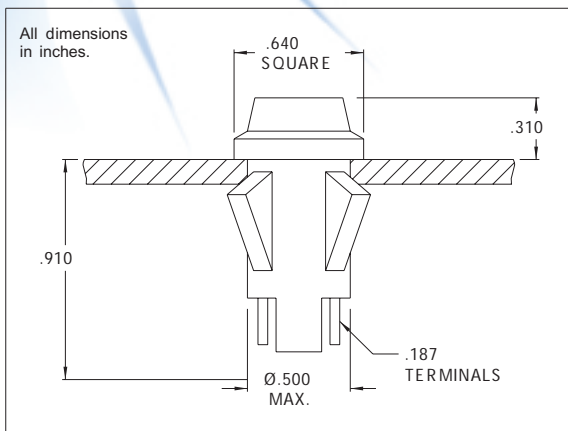

Mounting: Will snap-fit into Ø.500/.505 hole in panels .020/.100 thick. Push-on speednut SN0461 also available.
 Mounting hole pattern on page SP2.

Terminals: Quick-connect, Tinned brass

Lens: Polycarbonate

Bezel: Polished stainless steel.
 For black finish add "X" after the series letter(s).

Housing: White Nylon

	Neon
Lens Color	Model No. (105-125VAC)
Red	1050QN1
Amber	1050QN3
White	1050QN4
Green	1052QN5*
Lamp used	A2A+R resistor

* Incorporates G2B lamp and resistor.
 Underwriters Laboratories (UL) File No. E20325
 Canadian Standards Association (CSA) File No. LR13346