



# 1GB – 128Mx72 DDR2 SDRAM REGISTERED, w/PLL, Mini-DIMM

## FEATURES

- 244-pin, dual in-line memory module (Mini-DIMM)
- Fast data transfer rates: PC2-6400\*, PCS-5300\*, PC2-4200 and PC2-3200
- Utilizes 800\*, 667\*, 533 and 400 Mb/s DDR2 SDRAM components
- $V_{CC} = V_{CCQ} = 1.8V \pm 0.1V$
- $V_{CCSPD} = 1.7V$  to 3.6V
- Differential data strobe (DQS, DQS#) option
- Four-bit prefetch architecture
- Programmable CAS# latency (CL): 3, 4, 5\* and 6\*
- On-die termination (ODT)
- Serial Presence Detect (SPD) with EEPROM
- JEDEC Standard 1.8V I/O (SSTL\_18 Compatible)
- Gold (Au) edge contacts
- Single Rank
- RoHS compliant
- Package option
  - 244 Pin Mini-DIMM
  - PCB – 30.00mm (1.181") TYP

## DESCRIPTION

The WV3HG128M72EER is a 128Mx72 Double Data Rate DDR2 SDRAM high density module. This memory module consists of nine 128Mx8 bit with 4 banks DDR2 Synchronous DRAMs in FBGA packages, mounted on a 244-pin DIMM FR4 substrate.

\* This product is under development, is not qualified or characterized and is subject to change without notice.

NOTE: Consult factory for availability of:

- Vendor source control options
- Industrial temperature option

## OPERATING FREQUENCIES

	PC2-3200	PC2-4200	PC2-5300*	PC2-6400*
Clock Speed	200MHz	266MHz	333MHz	400MHz
CL-tRCD-tRP	3-3-3	4-4-4	5-5-5	6-6-6

\*Consult factory for availability.

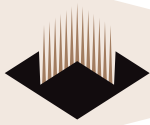

## PIN CONFIGURATION

Pin No.	Symbol	Pin No.	Symbol	Pin No.	Symbol	Pin No.	Symbol
1	VREF	62	A4	123	Vss	184	Vcc
2	Vss	63	Vcc	124	DQ4	185	A3
3	DQ0	64	A2	125	DQ5	186	A1
4	DQ1	65	Vcc	126	Vss	187	Vcc
5	Vss	66	Vss	127	DM0	188	CK0
6	DQS0#	67	Vss	128	NC	189	CK0#
7	DQS0	68	NC	129	Vss	190	Vcc
8	Vss	69	Vcc	130	DQ6	191	A0
9	DQ2	70	A10/AP	131	DQ7	192	BA1
10	DQ3	71	BA0	132	Vss	193	Vcc
11	Vss	72	Vcc	133	DQ12	194	RAS#
12	DQ8	73	WE#	134	DQ13	195	Vcc
13	DQ9	74	Vcc	135	Vss	196	CS0#
14	Vss	75	CAS#	136	DM1	197	Vcc
15	DQS1#	76	Vcc	137	NC	198	ODT0
16	DQS1	77	NC	138	Vss	199	A13
17	Vss	78	NC	139	NC	200	Vcc
18	RESET#	79	Vcc	140	NC	201	NC
19	NC	80	NC	141	Vss	202	Vss
20	Vss	81	Vss	142	DQ14	203	DQ36
21	DQ10	82	DQ32	143	DQ15	204	DQ37
22	DQ11	83	DQ33	144	Vss	205	Vss
23	Vss	84	Vss	145	DQ20	206	DM4
24	DQ16	85	DQS4#	146	DQ21	207	NC
25	DQ17	86	DQS4	147	Vss	208	Vss
26	Vss	87	Vss	148	DM2	209	DQ38
27	DQS2#	88	DQ34	149	NC	210	DQ39
28	DQS2	89	DQ35	150	Vss	211	Vss
29	Vss	90	Vss	151	DQ22	212	DQ44
30	DQ18	91	DQ40	152	DQ23	213	DQ45
31	DQ19	92	DQ41	153	Vss	214	Vss
32	Vss	93	Vss	154	DQ28	215	DM5
33	DQ24	94	DQS5#	155	DQ29	216	NC
34	DQ25	95	DQS5	156	Vss	217	Vss
35	Vss	96	Vss	157	DM3	218	DQ46
36	DQS3#	97	DQ42	158	NC	219	DQ47
37	DQS3	98	DQ43	159	Vss	220	Vss
38	Vss	99	Vss	160	DQ30	221	DQ52
39	DQ26	100	DQ48	161	DQ31	222	DQ53
40	DQ27	101	DQ49	162	Vss	223	Vss
41	Vss	102	Vss	163	CB4	224	NC
42	CB0	103	SA2	164	CB5	225	NC
43	CB1	104	NC	165	Vss	226	Vss
44	Vss	105	Vss	166	DM8	227	DM6
45	DQS8#	106	DQS6#	167	NC	228	NC
46	DQS8	107	DQS6	168	Vss	229	Vss
47	Vss	108	Vss	169	CB6	230	DQ54
48	CB2	109	DQ50	170	CB7	231	DQ55
49	CB3	110	DQ51	171	Vss	232	Vss
50	Vss	111	Vss	172	NC	233	DQ60
51	NC	112	DQ56	173	Vcc	234	DQ61
52	Vcc	113	DQ57	174	NC	235	Vss
53	CKE0	114	Vss	175	Vcc	236	DM7
54	Vcc	115	DQS7#	176	NC	237	NC
55	BA2	116	DQS7	177	NC	238	Vss
56	NC	117	Vss	178	Vcc	239	DQ62
57	Vcc	118	DQ58	179	A12	240	DQ63
58	A11	119	DQ59	180	A9	241	Vss
59	A7	120	Vss	181	Vcc	242	SDA
60	Vcc	121	SA0	182	A8	243	SCL
61	A5	122	SA1	183	A6	244	VccSPD

## PIN NAMES

Pin Name	Function
A0-A13	Address Inputs
BA0-BA2	SDRAM Bank Address
DQ0-DQ63	Data Input/Output
CB0-CB7	Check Bits
DQS0-DQS8	Data strobes
DQS0#-DQS8#	Data strobes complement
ODT0	On-die termination control
CK0,CK0#	Clock Inputs, positive line
CKE0	Clock Enables
CS0#	Chip Selects
RAS#	Row Address Strobe
CAS#	Column Address Strobe
WE#	Write Enable
RESET#	Register Reset Input
DM (0-8)	Data Masks
VccSPD	SPD Power
Vcc	Voltage Supply (1.8V±0.1V)
Vss	Ground
SA0-SA2	SPD address
SDA	SPD Data Input/Output
SCL	Serial Presence Detect (SPD) Clock Input
VREF	Input/Output Reference
NC	Spare pins, No connect

RESET (pin 18) is connected to both OE of the PLL and Reset# of the register .



**FUNCTIONAL BLOCK DIAGRAM**

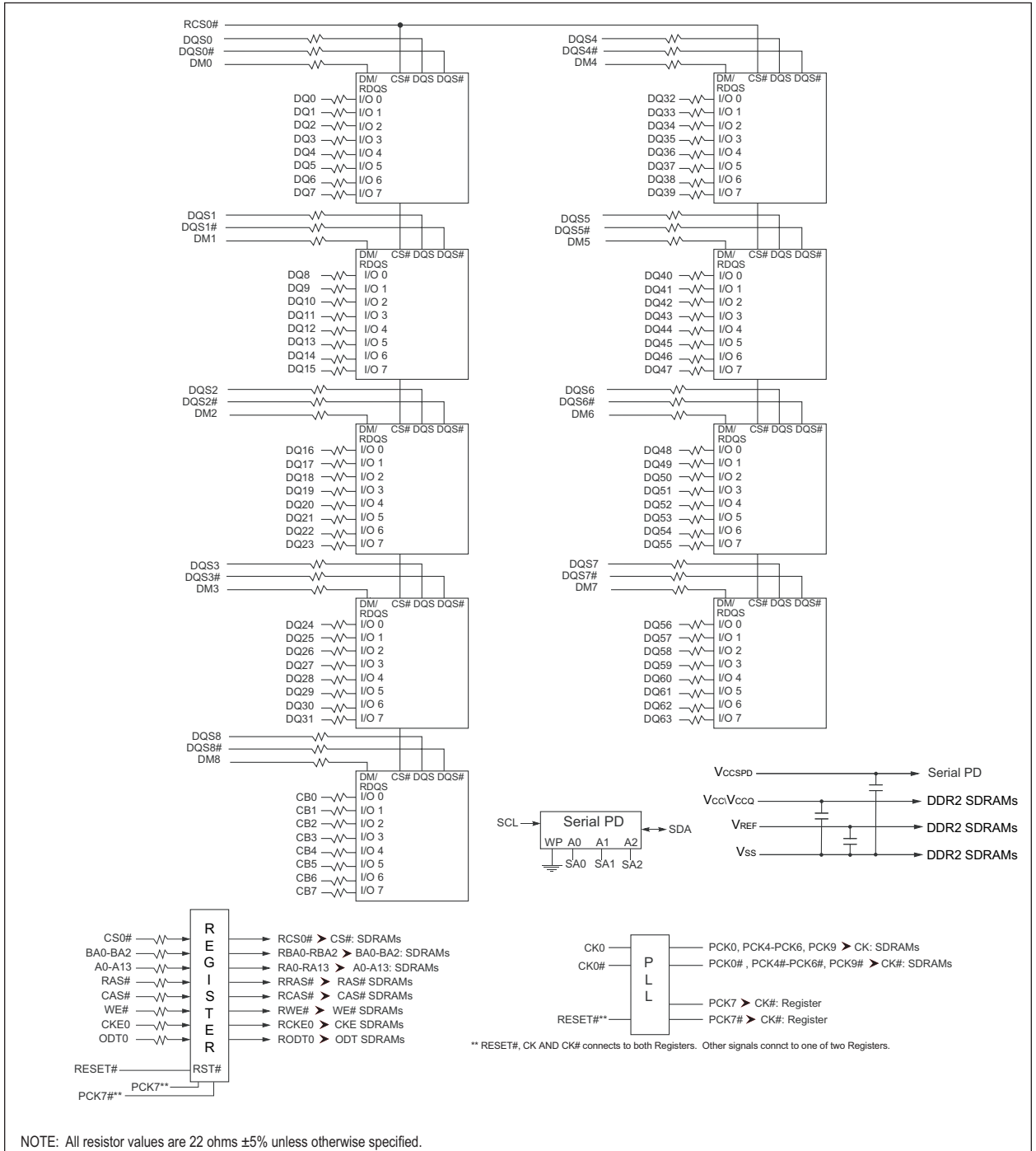

NOTE: All resistor values are 22 ohms ±5% unless otherwise specified.



**ABSOLUTE MAXIMUM RATINGS**

Symbol	Parameter	Min	Max	Units	
V <sub>CC</sub>	Voltage on V <sub>CC</sub> pin relative to V <sub>SS</sub>	-0.5	2.3	V	
V <sub>IN</sub> , V <sub>OUT</sub>	Voltage on any pin relative to V <sub>SS</sub>	-0.5	2.3	V	
T <sub>STG</sub>	Storage Temperature	-55	100	°C	
I <sub>L</sub>	Input leakage current; Any input 0V<V <sub>IN</sub> <V <sub>CC</sub> ; V <sub>REF</sub> input 0V,V <sub>IN</sub> ,0.95V; Other pins not under test = 0V	Command/Address, RAS#, CAS#, WE#,	-5	5	µA
		CK, CK#	-10	10	µA
		DM	-5	5	µA
I <sub>OZ</sub>	Output leakage current; 0V<V <sub>IN</sub> <V <sub>CC</sub> ; DQs and ODT are disable	DQ, DQS, DQS#	-5	5	µA
I <sub>VREF</sub>	V <sub>REF</sub> leakage current; V <sub>REF</sub> = Valid V <sub>REF</sub> level		-18	18	µA

**DC OPERATING CONDITIONS**

All voltages referenced to V<sub>SS</sub>

Parameter	Symbol	Min	Typical	Max	Unit	Notes
Supply Voltage	V <sub>CC</sub>	1.7	1.8	1.9	V	3
I/O Reference Voltage	V <sub>REF</sub>	0.49 x V <sub>CC</sub>	0.50 x V <sub>CC</sub>	0.51 x V <sub>CC</sub>	V	1
I/O Termination Voltage	V <sub>TT</sub>	V <sub>REF</sub> -0.04	V <sub>REF</sub>	V <sub>REF</sub> +0.04	V	2
SPD Supply Voltage	V <sub>CCSPD</sub>	1.7	-	3.6	V	

Notes:

- V<sub>REF</sub> is expected to equal V<sub>CCOZ</sub> of the transmitting device and to track variations in the DC level of the same. Peak-to-peak noise on V<sub>REF</sub> may not exceed +/-1 percent of the DC value. Peak-to-peak AC noise on V<sub>REF</sub> may not exceed +/-2 percent of V<sub>REF</sub>. This measurement is to be taken at the nearest V<sub>REF</sub> bypass capacitor.
- V<sub>TT</sub> is not applied directly to the device. V<sub>TT</sub> is a system supply for signal termination resistors, is expected to be set equal to V<sub>REF</sub> and must track variations in the DC level of V<sub>REF</sub>.
- V<sub>CCO</sub> of all IC's are tied to V<sub>CC</sub>.

**INPUT/OUTPUT CAPACITANCE**

TA=25 0 C, f=1 00MHz

Parameter	Symbol	Min	Max	Unit
Input capacitance (A0 - A13, BA0 - BA1 ,RAS#,CAS#,WE#)	C <sub>IN1</sub>	11	12	pF
Input capacitance (CKE0), (ODT0)	C <sub>IN2</sub>	11	12	pF
Input capacitance (CS0#)	C <sub>IN3</sub>	11	12	pF
Input capacitance (CK0, CK0#)	C <sub>IN4</sub>	10	11	pF
Input capacitance (DM0 - DM8), (DQS0 - DQS8)	C <sub>IN5</sub> (665)	6.5	8	pF
	C <sub>IN5</sub> (534,403)	6.5	7.5	pF
Input capacitance (DQ0 - DQ63), (CB0 - CB7)	C <sub>OUT1</sub> (665)	6.5	8	pF
	C <sub>OUT1</sub> (534,403)	6.5	7.5	pF



**OPERATING TEMPERATURE CONDITION**

Parameter	Symbol	Rating	Units	Notes
Operating temperature (Commercial)	T <sub>OPER</sub>	0°C to 85°C	°C	1, 2

- Notes:
1. Operating temperature is the case surface temperature on the center/top side of the DRAM. For the measurement conditions, please refer to JEDEC JESD51 .2
  2. At 0 - 85°C, operation temperature range, all DRAM specification will be supported.

**INPUT DC LOGIC LEVEL**

All voltages referenced to V<sub>SS</sub>

Parameter	Symbol	Min	Max	Unit
Input High (Logic 1 ) Voltage	V <sub>IH</sub> (DC)	V <sub>REF</sub> + 0.125	V <sub>REF</sub> + 0.300	V
Input Low (Logic 0) Voltage	V <sub>IL</sub> (DC)	-0.300	V <sub>REF</sub> - 0.125	V

**INPUT AC LOGIC LEVEL**

All voltages referenced to V<sub>SS</sub>

Parameter	Symbol	Min	Max	Unit
AC Input High (Logic 1 ) Voltage DDR2-400 & DDR2-533	V <sub>IH</sub> (AC)	V <sub>REF</sub> + 0.250	—	V
AC Input High (Logic 1 ) Voltage DDR2-667	V <sub>IH</sub> (AC)	V <sub>REF</sub> + 0.200	—	V
AC Input Low (Logic 0) Voltage DDR2-400 & DDR2-533	V <sub>IL</sub> (AC)	—	V <sub>REF</sub> - 0.250	V
AC Input Low (Logic 1 ) Voltage DDR2-667, DDR2-800(TBD)	V <sub>IL</sub> (AC)	—	V <sub>REF</sub> - 0.200	V



**DDR2 I<sub>CC</sub> SPECIFICATIONS AND CONDITIONS**

V<sub>CC</sub> = +1.8V ± 0.1V

Symbol	Parameter	Condition	806	665	534	403	Unit	
I <sub>CC0</sub> *	Operating one bank active-precharge;	t <sub>CK</sub> = t <sub>CK(I<sub>CC</sub>)</sub> ; t <sub>RC</sub> = t <sub>RC(I<sub>CC</sub>)</sub> ; t <sub>RAS</sub> = t <sub>RAS MIN(I<sub>CC</sub>)</sub> ; CKE is HIGH, CS# is HIGH between valid commands; Address bus inputs are SWITCHING; Data bus inputs are SWITCHING	TBD	1,210	1,165	1,120	mA	
I <sub>CC1</sub> *	Operating one bank active-read-precharge;	I <sub>OUT</sub> = 0mA; BL = 4; CL = CL(I <sub>CC</sub> ); t <sub>CK</sub> = t <sub>CK(I<sub>CC</sub>)</sub> ; t <sub>RC</sub> = t <sub>RC(I<sub>CC</sub>)</sub> ; t <sub>RAS</sub> = t <sub>RAS MIN(I<sub>CC</sub>)</sub> ; CKE is HIGH, CS# is HIGH between valid commands; Address bus inputs are SWITCHING; Data bus inputs are SWITCHING; Data pattern is same as I <sub>CC4W</sub> .	TBD	1,300	1,255	1,210	mA	
I <sub>CC2P</sub> **	Precharge power-down current;	All banks idle; t <sub>CK</sub> = t <sub>CK(I<sub>CC</sub>)</sub> ; CKE is LOW; Other control and address bus inputs are STABLE; Data bus inputs are FLOATING	TBD	508	508	508	mA	
I <sub>CC2Q</sub> **	Precharge quiet standby current;	All banks idle; t <sub>CK</sub> = t <sub>CK(I<sub>CC</sub>)</sub> ; CKE is HIGH; CS# is HIGH; Other control and address bus inputs are STABLE; Data bus inputs are FLOATING	TBD	760	715	715	mA	
I <sub>CC2N</sub> **	Precharge standby current;	All banks idle; t <sub>CK</sub> = t <sub>CK(I<sub>CC</sub>)</sub> ; CKE is HIGH; CS# is HIGH; Other control and address bus inputs are STABLE; Data bus inputs are SWITCHING	TBD	805	760	760	mA	
I <sub>CC3P</sub> **	Active power-down current;	All banks open; t <sub>CK</sub> = t <sub>CK(I<sub>CC</sub>)</sub> ; CKE is LOW; Other control and address bus inputs are STABLE; Data bus inputs are FLOATING	Fast PDN Exit MRS(12) = 0	TBD	670	625	625	mA
			Slow PDN Exit MRS(12) = 1	TBD	508	508	508	mA
I <sub>CC3N</sub> **	Active standby current;	All banks open; t <sub>CK</sub> = t <sub>CK(I<sub>CC</sub>)</sub> ; t <sub>RC</sub> = t <sub>RC(I<sub>CC</sub>)</sub> ; t <sub>RAS</sub> = t <sub>RAS MIN(I<sub>CC</sub>)</sub> ; CKE is HIGH, CS# is HIGH between valid commands; Other control and address bus inputs are SWITCHING; Data bus inputs are SWITCHING	TBD	850	805	805	mA	
I <sub>CC4W</sub> *	Operating burst write current;	All banks open; Continuous burst writes; BL = 4; CL = CL(I <sub>CC</sub> ); AL = 0; t <sub>CK</sub> = t <sub>CK(I<sub>CC</sub>)</sub> ; t <sub>RC</sub> = t <sub>RC(I<sub>CC</sub>)</sub> ; t <sub>RAS</sub> = t <sub>RAS MIN(I<sub>CC</sub>)</sub> ; CKE is HIGH, CS# is HIGH between valid commands; Address bus inputs are SWITCHING; Data bus inputs are SWITCHING	TBD	1,795	1,570	1,435	mA	
I <sub>CC4R</sub> *	Operating burst read current;	All banks open; Continuous burst reads; TOUT = 0mA; BL = 4; CL = CL(I <sub>CC</sub> ); AL = 0; t <sub>CK</sub> = t <sub>CK(I<sub>CC</sub>)</sub> ; t <sub>RC</sub> = t <sub>RC(I<sub>CC</sub>)</sub> ; t <sub>RAS</sub> = t <sub>RAS MIN(I<sub>CC</sub>)</sub> ; CKE is HIGH, CS# is HIGH between valid commands; Address bus inputs are SWITCHING; Data pattern is same as I <sub>CC4W</sub> .	TBD	1,795	1,570	1,435	mA	
I <sub>CC5</sub> **	Burst auto refresh current;	t <sub>CK</sub> = t <sub>CK(I<sub>CC</sub>)</sub> ; Refresh command at every t <sub>RC(I<sub>CC</sub>)</sub> interval; CKE is HIGH; CS# is HIGH between valid commands; Other control and address bus inputs are SWITCHING; Data bus inputs are SWITCHING	TBD	2,380	2,335	2,290	mA	
I <sub>CC6</sub> **	Self refresh current;	CK and CK# at 0V; CKE < 0.2V; Other control and address bus inputs are FLOATING; Data bus inputs are FLOATING	Normal	TBD	90	90	90	mA
I <sub>CC7</sub> *	Operating bank interleave read current;	All bank interleaving reads; I <sub>OUT</sub> = 0mA; BL = 4; CL = CL(I <sub>CC</sub> ); AL = t <sub>RCD(I<sub>CC</sub>)</sub> - 1*t <sub>CK(I<sub>CC</sub>)</sub> ; t <sub>CK</sub> = t <sub>CK(I<sub>CC</sub>)</sub> ; t <sub>RC</sub> = t <sub>RC(I<sub>CC</sub>)</sub> ; t <sub>RRD</sub> = t <sub>RRD MIN(I<sub>CC</sub>)</sub> = 1*t <sub>CK(I<sub>CC</sub>)</sub> ; CKE is HIGH; CS# is HIGH between valid commands; Address bus inputs are STABLE during DESELECTs; Data bus inputs are SWITCHING	TBD	3,100	2,920	2,740	mA	

Notes:

I<sub>CC</sub> specification is based on **SAMSUNG** components. Other DRAM manufacturers specification may be different.

\* Value calculated as one module rank in this operating condition, and all other module ranks in I<sub>CC2P</sub> (CKE LOW) mode.

\*\* Value calculated reflects all module ranks in this operating condition.



**AC TIMING PARAMETERS**

V<sub>CC</sub> = +1.8V ± 0.1V

Parameter		Symbol	806		665		534		403		Unit	
			Min	Max	Min	Max	Min	Max	Min	Max		
Clock	Clock cycle time	CL=6	t <sub>CK(6)</sub>	TBD	TBD							
		CL=5	t <sub>CK(5)</sub>	TBD	TBD	3000	8000	-	-	-	-	ps
		CL=4	t <sub>CK(4)</sub>	TBD	TBD	3750	8000	3,750	8,000	5,000	8,000	ps
		CL=3	t <sub>CK(3)</sub>	TBD	TBD	5000	8000	5,000	8,000	5,000	8,000	ps
	CK high-level width	t <sub>CH</sub>	TBD	TBD	0.45	0.55	0.45	0.55	0.45	0.55	t <sub>CK</sub>	
	CK low-level width	t <sub>CL</sub>	TBD	TBD	0.45	0.55	0.45	0.55	0.45	0.55	t <sub>CK</sub>	
	Half clock period	t <sub>HP</sub>	TBD	TBD	MIN(t <sub>CH</sub> , t <sub>CL</sub> )		MIN(t <sub>CH</sub> , t <sub>CL</sub> )		MIN(t <sub>CH</sub> , t <sub>CL</sub> )		ps	
Clock jitter	t <sub>JIT</sub>	TBD	TBD	-125	125	-125	125	-125	125	ps		
Data	DQ output access time from CK/CK#	t <sub>AC</sub>	TBD	TBD	-450	+450	-500	+500	-600	+600	ps	
	Data-out high impedance window from CK/CK#	t <sub>HZ</sub>	TBD	TBD		t <sub>AC(MAX)</sub>		t <sub>AC(MAX)</sub>		t <sub>AC(MAX)</sub>	ps	
	Data-out low-impedance window from CK/CK#	t <sub>LZ</sub>	TBD	TBD	t <sub>AC(MIN)</sub>	t <sub>AC(MAX)</sub>	t <sub>AC(MIN)</sub>	t <sub>AC(MAX)</sub>	t <sub>AC(MIN)</sub>	t <sub>AC(MAX)</sub>	ps	
	DQ and DM input setup time relative to DQS	t <sub>DS</sub>	TBD	TBD	100		100		150			
	DQ and DM input hold time relative to DQS	t <sub>DH</sub>	TBD	TBD	175		225		275			
	DQ and DM input pulse width (for each input)	t <sub>DIPW</sub>	TBD	TBD	0.35		0.35		0.35		t <sub>CK</sub>	
	Data hold skew factor	t <sub>QHS</sub>	TBD	TBD		340		400		450	ps	
	DQ-DQS hold, DQS to first DQ to go nonvalid, per access	t <sub>QH</sub>	TBD	TBD	t <sub>HP</sub> - t <sub>QHS</sub>		t <sub>HP</sub> - t <sub>QHS</sub>		t <sub>HP</sub> - t <sub>QHS</sub>		ps	
	Data valid output window (DVW)	t <sub>DVW</sub>	TBD	TBD	t <sub>QH</sub> - t <sub>DQSQ</sub>		t <sub>QH</sub> - t <sub>DQSQ</sub>		t <sub>QH</sub> - t <sub>DQSQ</sub>		ns	
Data Strobe	DQS input high pulse width	t <sub>DQSH</sub>	TBD	TBD	0.35		0.35		0.35		t <sub>CK</sub>	
	DQS input low pulse width	t <sub>DQSL</sub>	TBD	TBD	0.35		0.35		0.35		t <sub>CK</sub>	
	DQS output access time from CK/CK#	t <sub>DQSQ</sub>	TBD	TBD	-400	+400	-450	+450	-500	+500	ps	
	DQS falling edge to CK rising - setup time	t <sub>DSS</sub>	TBD	TBD	0.2		0.2		0.2		t <sub>CK</sub>	
	DQS falling edge from CK rising - hold time	t <sub>DSH</sub>	TBD	TBD	0.2		0.2		0.2		t <sub>CK</sub>	
	DQS-DQ skew, DOS to last DQ valid, per group, per access	t <sub>DQSQ</sub>	TBD	TBD		240		300		350	ps	
	DQS read preamble	t <sub>RPRE</sub>	TBD	TBD	0.9	1.1	0.9	1.1	0.9	1.1	t <sub>CK</sub>	
	DQS read postamble	t <sub>RPST</sub>	TBD	TBD	0.4	0.6	0.4	0.6	0.4	0.6	t <sub>CK</sub>	
	DQS write preamble setup time	t <sub>WPRES</sub>	TBD	TBD	0		0		0		ps	
	DQS write preamble	t <sub>WPRE</sub>	TBD	TBD	0.35		0.35		0.35		t <sub>CK</sub>	
	DQS write postamble	t <sub>WPST</sub>	TBD	TBD	0.4	0.6	0.4	0.6	0.4	0.6	t <sub>CK</sub>	
	Write command to first DQS latching transition	t <sub>DQSS</sub>	TBD	TBD	WL-0.25	WL+0.25	WL-0.25	WL+0.25	WL-0.25	WL+0.25	t <sub>CK</sub>	

AC specification is based on **SAMSUNG** components. Other DRAM manufacturers specification may be different.



**AC TIMING PARAMETERS (continued)**

V<sub>CC</sub> = +1.8V ± 0.1V

Parameter	Symbol	806		665		534		403		Unit	
		Min	Max	Min	Max	Min	Max	Min	Max		
Command and Address	Address and control input pulse width for each input	t <sub>IPW</sub>	TBD	TBD	0.6		0.6		0.6		t <sub>CK</sub>
	Address and control input setup time	t <sub>IS</sub>	TBD	TBD	200		250		250		ps
	Address and control input hold time	t <sub>IH</sub>	TBD	TBD	275		375		475		ps
	CAS# to CAS# command delay	t <sub>CCD</sub>	TBD	TBD	2		2		2		ps
	ACTIVE to ACTIVE (same bank) command	t <sub>RC</sub>	TBD	TBD	55		55		55		ns
	ACTIVE bank a to ACTIVE bank b command	t <sub>RRD</sub>	TBD	TBD	7.5		7.5		7.5		ns
	ACTIVE to READ or WRITE delay	t <sub>RCD</sub>	TBD	TBD	15		15		15		ns
	Four Bank Activate period	t <sub>FAW</sub>	TBD	TBD	37.5		37.5		37.5		ns
	ACTIVE to PRECHARGE command	t <sub>RAS</sub>	TBD	TBD	40	70,000	40	70,000	40	70,000	ns
	Internal READ to precharge command delay	t <sub>RTP</sub>	TBD	TBD	7.5		7.5		7.5		ns
	Write recovery time	t <sub>WR</sub>	TBD	TBD	15		15		15		ns
	Auto precharge write recovery + precharge time	t <sub>DAL</sub>	TBD	TBD	t <sub>WR</sub> + t <sub>RP</sub>		t <sub>WR</sub> + t <sub>RP</sub>		t <sub>WR</sub> + t <sub>RP</sub>		ns
	Internal WRITE to READ command delay	t <sub>WTR</sub>	TBD	TBD	7.5		7.5		10		ns
	PRECHARGE command period	t <sub>RP</sub>	TBD	TBD	15		15		15		ns
	PRECHARGE ALL command period	t <sub>RPA</sub>	TBD	TBD	t <sub>RP</sub> + t <sub>CK</sub>		t <sub>RP</sub> + t <sub>CK</sub>		t <sub>RP</sub> + t <sub>CK</sub>		ns
	LOAD MODE command cycle time	t <sub>MRD</sub>	TBD	TBD	2		2		2		t <sub>CK</sub>
CKE low to CK, CK# uncertainty	t <sub>DELAY</sub>	TBD	TBD	t <sub>IS</sub> +t <sub>CK</sub> +t <sub>IH</sub>		t <sub>IS</sub> +t <sub>CK</sub> +t <sub>IH</sub>		t <sub>IS</sub> +t <sub>CK</sub> +t <sub>IH</sub>		ns	
Self Refresh	REFRESH to Active or Refresh to Refresh command interval	t <sub>RFC</sub>	TBD	TBD	127.5	70,000	127.5	70,000	127.5	70,000	ns
	Average periodic refresh interval	t <sub>REFI</sub>	TBD	TBD		7.8		7.8		7.8	μs
	Exit self refresh to non-READ command	t <sub>XSNR</sub>	TBD	TBD	t <sub>RFC(MIN)</sub> + 10		t <sub>RFC(MIN)</sub> + 10		t <sub>RFC(MIN)</sub> + 10		ns
	Exit self refresh to READ	t <sub>XSRD</sub>	TBD	TBD	200		200		200		t <sub>CK</sub>
	Exit self refresh timing reference	t <sub>ISXR</sub>	TBD	TBD	t <sub>IS</sub>		t <sub>IS</sub>		t <sub>IS</sub>		ps
ODT	ODT turn-on delay	t <sub>AOND</sub>	TBD	TBD	2	2	2	2	2	2	t <sub>CK</sub>
	ODT turn-on	t <sub>ACN</sub>	TBD	TBD	t <sub>AC(MIN)</sub>	t <sub>AC(MAX)</sub> + 1000	t <sub>AC(MIN)</sub>	t <sub>AC(MAX)</sub> + 1000	t <sub>AC(MIN)</sub>	t <sub>AC(MAX)</sub> + 1000	ps
	ODT turn-off delay	t <sub>AOFD</sub>	TBD	TBD	2.5	2.5	2.5	2.5	2.5	2.5	t <sub>CK</sub>
	ODT turn-off	t <sub>AOF</sub>	TBD	TBD	t <sub>AC(MIN)</sub>	t <sub>AC(MAX)</sub> + 600	t <sub>AC(MIN)</sub>	t <sub>AC(MAX)</sub> + 600	t <sub>AC(MIN)</sub>	t <sub>AC(MAX)</sub> + 600	ps
	ODT turn-on (power-down mode)	t <sub>AONPD</sub>	TBD	TBD	t <sub>AC(MIN)</sub> + 2000	2 x t <sub>CK</sub> + t <sub>AC(MAX)</sub> + 1000	t <sub>AC(MIN)</sub> + 2000	2 x t <sub>CK</sub> + t <sub>AC(MAX)</sub> + 1000	t <sub>AC(MIN)</sub> + 2000	2 x t <sub>CK</sub> + t <sub>AC(MAX)</sub> + 1000	ps
	ODT turn-off (power-down mode)	t <sub>AOFFPD</sub>	TBD	TBD	t <sub>AC(MIN)</sub> + 2000	2.5 x t <sub>CK</sub> + t <sub>AC(MAX)</sub> + 1000	t <sub>AC(MIN)</sub> + 2000	2.5 x t <sub>CK</sub> + t <sub>AC(MAX)</sub> + 1000	t <sub>AC(MIN)</sub> + 2000	2.5 x t <sub>CK</sub> + t <sub>AC(MAX)</sub> + 1000	ps
	ODT to power-down entry latency	t <sub>ANPD</sub>	TBD	TBD	3		3		3		t <sub>CK</sub>
	ODT power-down exit latency	t <sub>AXPD</sub>	TBD	TBD	8		8		8		t <sub>CK</sub>
Power-Down	Exit active power-down to READ command, MR[bit12=0]	t <sub>XARD</sub>	TBD	TBD	2		2		2		t <sub>CK</sub>
	Exit active power-down to READ command, MR[bit12=1]	t <sub>XARDS</sub>	TBD	TBD	7-AL		6-AL		6-AL		t <sub>CK</sub>
	Exit precharge power-down to any non-READ command	t <sub>XP</sub>	TBD	TBD	2		2		2		t <sub>CK</sub>
	CKE minimum high/low time	t <sub>CKE</sub>	TBD	TBD	3		3		3		t <sub>CK</sub>

AC specification is based on **SAMSUNG** components. Other DRAM manufacturers specification may be different.





### ORDERING INFORMATION FOR D7

Part Number	Clock Speed/ Data Rate	CAS Latency	t <sub>RC</sub> D	t <sub>RP</sub>	Height*
WV3HG128M72EER806D7xxG**	400MHz/800Mb/s	6	6	6	30.00mm (1.181") TYP
WV3HG128M72EER665D7xxG**	333MHz/667Mb/s	5	5	5	30.00mm (1.181") TYP
WV3HG128M72EER534D7xxG	266MHz/533Mb/s	4	4	4	30.00mm (1.181") TYP
WV3HG128M72EER403D7xxG	200MHz/400Mb/s	3	3	3	30.00mm (1.181") TYP

\*\* Contact factory for availability.

#### NOTES:

- RoHS product. ("G" = RoHS Compliant)
- Vendor specific part numbers are used to provide memory components source control. The place holder for this is shown as lower case "x" in the part numbers above and is to be replaced with the respective vendors code. Consult factory for qualified sourcing options. (M = Micron, S = Samsung & consult factory for others)
- Consult factory for availability of industrial temperature (-40°C to 85°C) option

### PACKAGE DIMENSIONS FOR D7

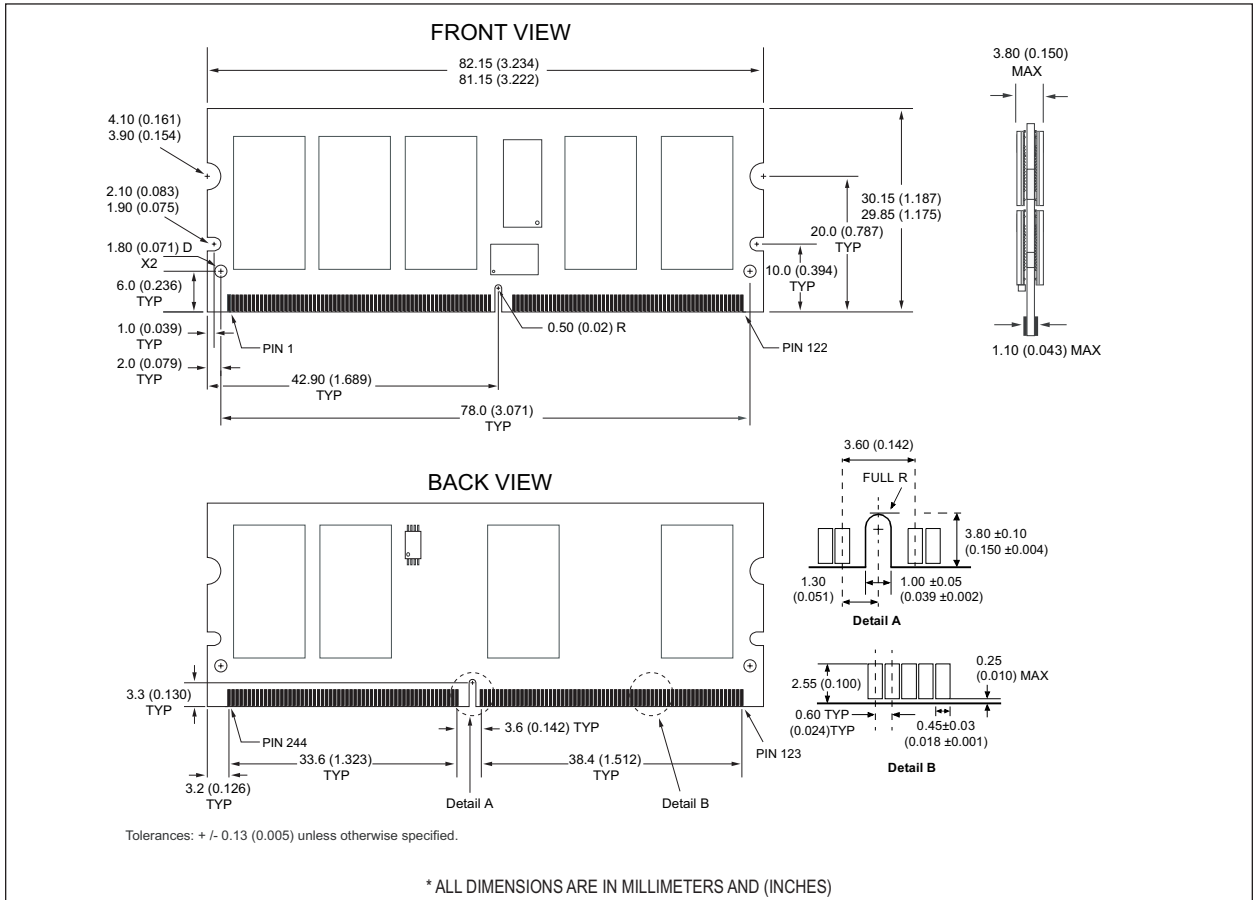



**PART NUMBERING GUIDE**

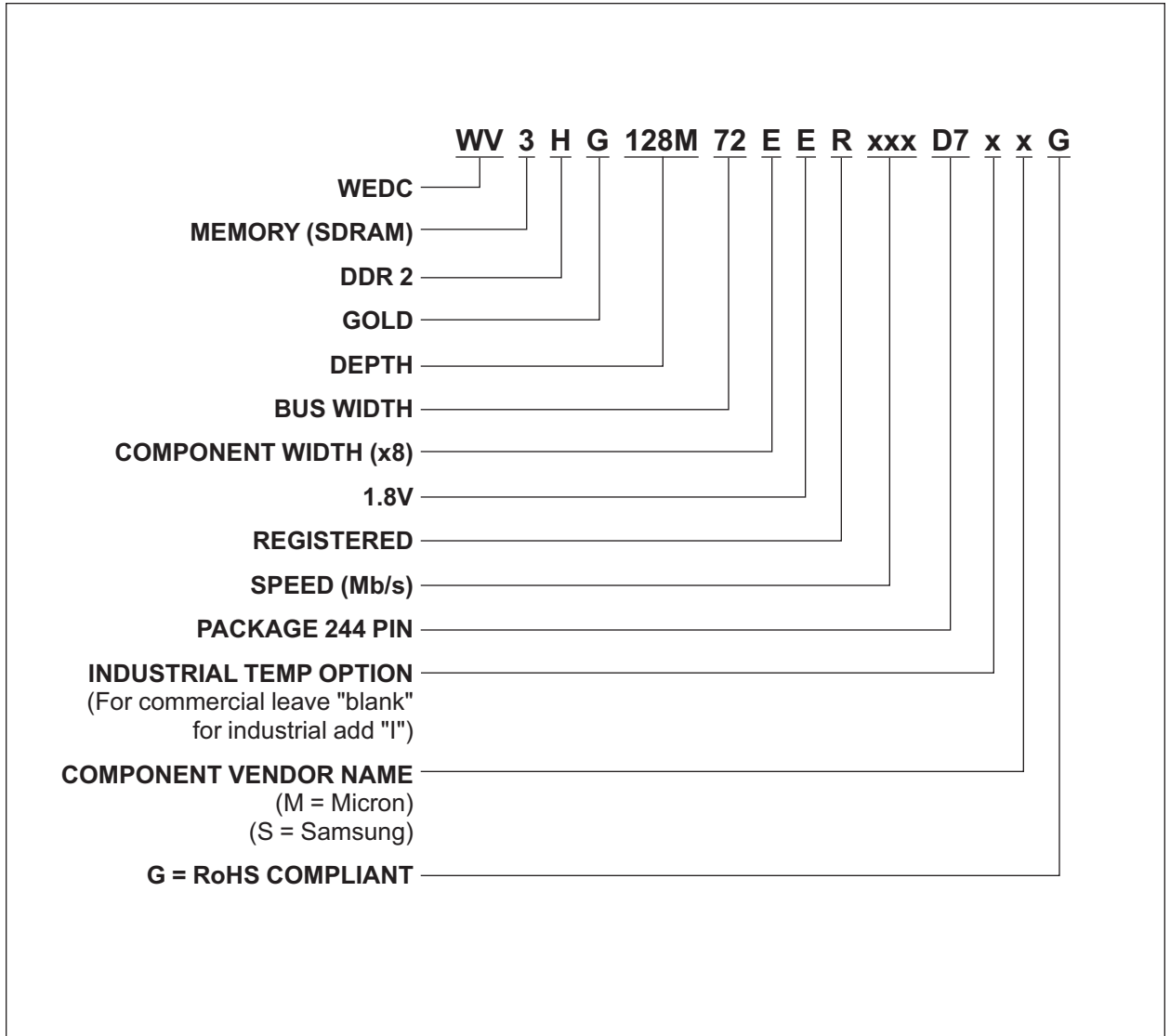



**Document Title**

1GB – 128Mx72 DDR2 SDRAM REGISTERED, w/PLL, Mini-DIMM

DRAM DIE OPTIONS:

- SAMSUNG: B-Die
- MICRON: U28A:A: will move to U38z:D Q4'06 and U488:E Q2'07

**Revision History**

<b>Rev #</b>	<b>History</b>	<b>Release Date</b>	<b>Status</b>
Rev 0	Created	May 2006	Advanced