

10-TAP DIP/SMD DELAY LINE

$T_D/T_R = 5$
(SERIES 1520)



FEATURES

- 10 taps of equal delay increment
- Delays to 1000ns
- Low profile
- Epoxy encapsulated
- Meets or exceeds MIL-D-23859C

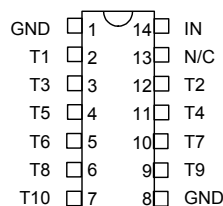

PACKAGES

IN Signal Input
T1-T10 Tap Outputs
GND Ground

Note: Standard pinout shown
Other pinouts available

FUNCTIONAL DESCRIPTION

The 1520-series device is a fixed, single-input, ten-output, passive delay line. The signal input (IN) is reproduced at the outputs (T1-T10) in equal increments. The delay from IN to T10 (T_D) and the characteristic impedance of the line (Z) are determined by the dash number. The rise time (T_R) of the line is 20% of T_D , and the 3dB bandwidth is given by $1.75 / T_D$. The device is available in a 14-pin DIP (1520) or a 14-pin SMD (1520S), and a wide range of pinouts may be specified.

Part numbers are constructed according to the scheme shown at right. For example, 1520C-101-500B is a 290 mil DIP, 100ns, 50 Ω delay line with pinout code B. Similarly, 1520SB-201-251 is a 240 mil SMD, 200ns, 250 Ω delay line with standard pinout.

PART NUMBER CONSTRUCTION

1520(S)m - xxx - zzz p

MOUNTING HEIGHT CODE
See Table

DELAY TIME
Expressed in nanoseconds (ns)
First two digits are significant figures
Last digit specifies # of zeros to follow

IMPEDANCE
Expressed in nanoseconds (ns)
First two digits are significant figures
Last digit specifies # of zeros to follow

PINOUT CODE
See Table
Omit for STD pinout

SERIES SPECIFICATIONS

- Dielectric breakdown: 50 Vdc
- Distortion @ output: 10% max.
- Operating temperature: -55°C to +125°C
- Storage temperature: -55°C to +125°C
- Temperature coefficient: 100 PPM/°C

PINOUT CODES

| CODE | IN | T1 | T2 | T3 | T4 | T5 | T6 | T7 | T8 | T9 | T10 | GND |
|------|----|----|----|----|----|-----|----|----|----|----|-----|--------|
| STD | 14 | 2 | 12 | 3 | 11 | 4 | 5 | 10 | 6 | 9 | 7 | 1,8 |
| A | 1 | 2 | 13 | 3 | 12 | 4 | 10 | 5 | 9 | 6 | 7 | 14 |
| B | 2 | 3 | 4 | 5 | 6 | 7 | 9 | 10 | 11 | 12 | 13 | 1,14 |
| C | 7 | 9 | 6 | 10 | 5 | 11 | 12 | 3 | 13 | 2 | 14 | 1,8 |
| D | 1 | 13 | 2 | 12 | 3 | 11 | 4 | 10 | 5 | 9 | 6 | 7,8,14 |
| E | 2 | 3 | 4 | 5 | 6 | 7,8 | 9 | 10 | 11 | 12 | 13 | 1,14 |
| F | 1 | 13 | 2 | 12 | 3 | 11 | 4 | 10 | 5 | 9 | 6 | 7 |
| G | 2 | 13 | 3 | 12 | 4 | 11 | 5 | 10 | 6 | 9 | 7 | 8,14 |
| H | 2 | 3 | 4 | 12 | 6 | 7 | 9 | 10 | 11 | 12 | 13 | 1 |
| I | 1 | 13 | 2 | 12 | 3 | 11 | 5 | 10 | 6 | 9 | 7 | 8,14 |
| J | 1 | 2 | 13 | 3 | 12 | 4 | 10 | 5 | 9 | 6 | 7 | 8,14 |
| K | 1 | 2 | 3 | 4 | 5 | 6 | 12 | 11 | 10 | 9 | 8 | 7 |
| L | 13 | 12 | 11 | 10 | 9 | 7,8 | 6 | 5 | 4 | 3 | 2 | 1,14 |
| N | 1 | 2 | 3 | 4 | 5 | 6 | 10 | 11 | 12 | 13 | 14 | 7 |
| P | 1 | 13 | 3 | 12 | 4 | 11 | 5 | 10 | 6 | 9 | 7 | 8,14 |
| T | 1 | 2 | 3 | 4 | 5 | 6 | 9 | 10 | 11 | 12 | 13 | 7,14 |
| U | 2 | 3 | 4 | 5 | 6 | 8 | 9 | 10 | 11 | 12 | 13 | 1,7 |
| V | 2 | 3 | 4 | 5 | 6 | 8 | 9 | 10 | 11 | 12 | 13 | 1 |
| W | 1 | 13 | 2 | 12 | 3 | 11 | 4 | 10 | 5 | 9 | 6 | 7,14 |
| Z | 1 | 13 | 3 | 12 | 4 | 11 | 5 | 10 | 6 | 9 | 8 | 7 |

DELAY SPECIFICATIONS

| T_D (ns) | T_1 (ns) | T_R (ns) | ATTENUATION (%) TYPICAL | | | | |
|---------------|---------------|---------------|-------------------------|----------------|----------------|----------------|----------------|
| | | | Z=50 Ω | Z=100 Ω | Z=200 Ω | Z=300 Ω | Z=500 Ω |
| 10 | 1.0 | 3.0 | 3 | 5 | N/A | N/A | N/A |
| 20 | 2.0 | 5.5 | 3 | 5 | 5 | N/A | N/A |
| 30 | 3.0 | 6.5 | 3 | 5 | 5 | N/A | N/A |
| 40 | 4.0 | 8.0 | 3 | 5 | 5 | 5 | N/A |
| 50 | 5.0 | 10.0 | 3 | 5 | 5 | 5 | 7 |
| 60 | 6.0 | 12.0 | 3 | 5 | 5 | 5 | 7 |
| 75 | 7.5 | 15.0 | 3 | 5 | 5 | 5 | 7 |
| 100 | 10.0 | 20.0 | 3 | 5 | 5 | 7 | 7 |
| 120 | 12.0 | 24.0 | 3 | 5 | 6 | 7 | 8 |
| 150 | 15.0 | 30.0 | 3 | 5 | 6 | 7 | 8 |
| 180 | 18.0 | 36.0 | 4 | 5 | 6 | 7 | 8 |
| 200 | 20.0 | 40.0 | 4 | 5 | 6 | 7 | 8 |
| 220 | 22.0 | 44.0 | 4 | 5 | 6 | 7 | 8 |
| 250 | 25.0 | 50.0 | 4 | 5 | 6 | 7 | 8 |
| 300 | 30.0 | 60.0 | N/A | 5 | 8 | 10 | 10 |
| 375 | 37.5 | 75.0 | N/A | 7 | 8 | 10 | 10 |
| 500 | 50.0 | 100.0 | N/A | 8 | 10 | 12 | 12 |
| 600 | 60.0 | 120.0 | N/A | N/A | N/A | 15 | 15 |
| 750 | 75.0 | 150.0 | N/A | N/A | N/A | 15 | 20 |
| 1000 | 100.0 | 200.0 | N/A | N/A | N/A | N/A | 20 |

Notes: T_1 represents nominal tap-to-tap delay increment
Tolerance on $T_D = \pm 5\%$ or ± 2 ns, whichever is greater
Tolerance on $T_1 = \pm 5\%$ or ± 1 ns, whichever is greater
"N/A" indicates that delay is not available at this Z

©2004 Data Delay Devices

FUNCTIONAL DIAGRAM

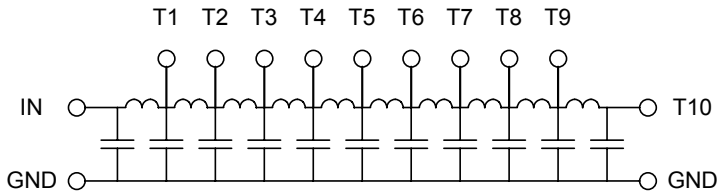

MOUNTING HEIGHT CODES

| CODE | HEIGHT (MAX) | DIP | SMD |
|------|--------------|-----|-----|
| A | 0.187 | Yes | No |
| B | 0.240 | Yes | Yes |
| C | 0.290 | Yes | Yes |

Note: Codes A and B are not available for all values of T_D
Contact technical staff for details

PACKAGE DIMENSIONS

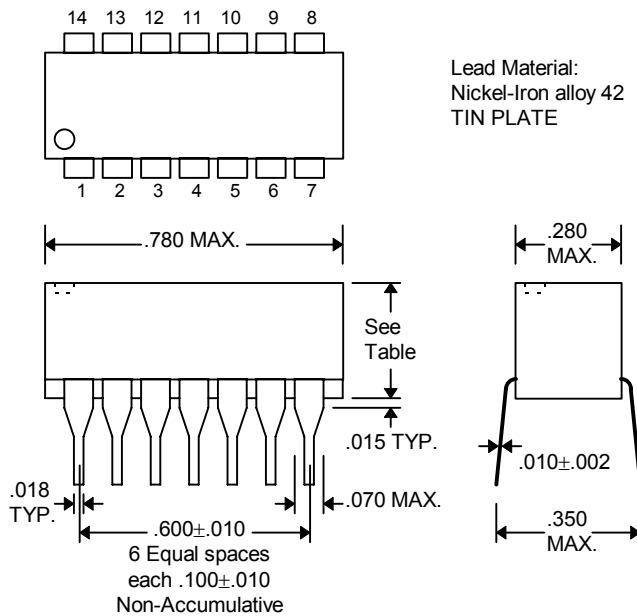

1520-xx (DIP)

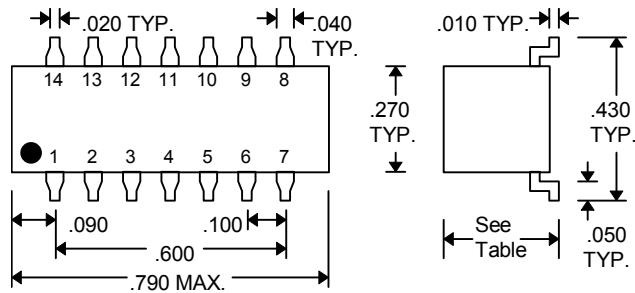

1520S-xx (Gull-Wing)

PASSIVE DELAY LINE TEST SPECIFICATIONS

TEST CONDITIONS

INPUT:

Ambient Temperature: $25^{\circ}\text{C} \pm 3^{\circ}\text{C}$
Input Pulse: High = 3.0V typical
 Low = 0.0V typical
Source Impedance: 50Ω Max.
Rise/Fall Time: 3.0 ns Max. (measured at 10% and 90% levels)

Pulse Width ($T_D \leq 75\text{ns}$): $PW_{IN} = 100\text{ns}$
Period ($T_D \leq 75\text{ns}$): $PER_{IN} = 1000\text{ns}$
Pulse Width ($T_D > 75\text{ns}$): $PW_{IN} = 2 \times T_D$
Period ($T_D > 75\text{ns}$): $PER_{IN} = 10 \times T_D$

OUTPUT:

R_{load} : 10MΩ
 C_{load} : 10pf
Threshold: 50% (Rising & Falling)

NOTE: The above conditions are for test only and do not in any way restrict the operation of the device.

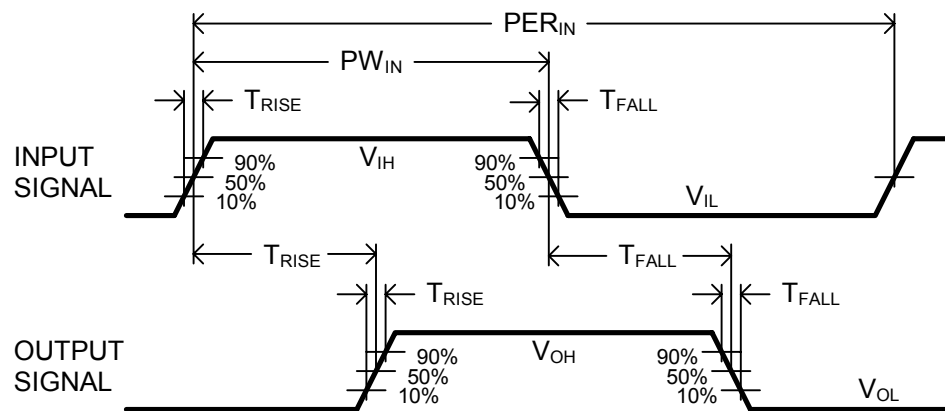

Timing Diagram For Testing

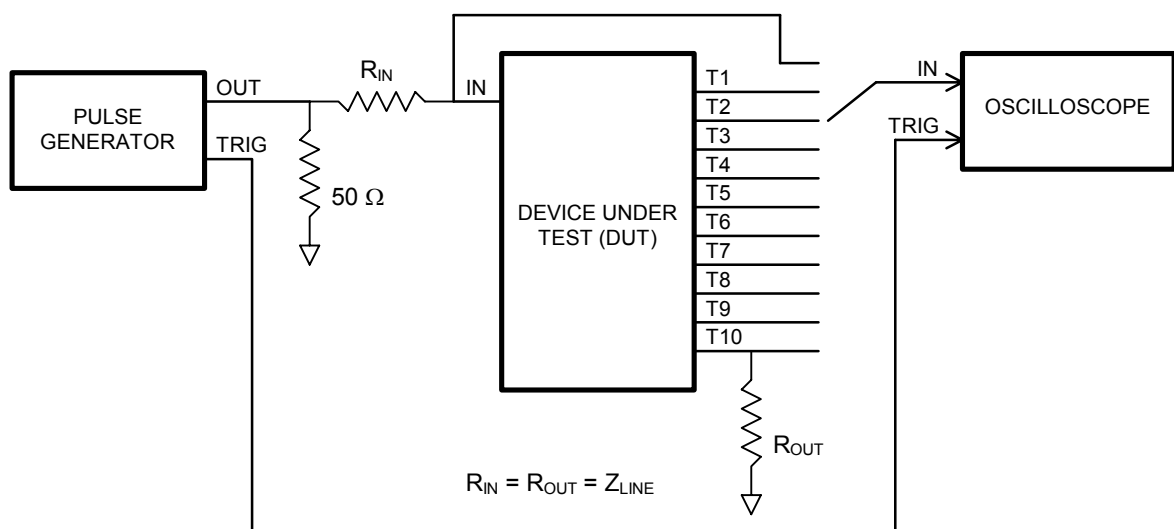

Test Setup