

HIGH RELIABILITY HYBRID DC-DC CONVERTERS

DESCRIPTION

The DVSA series of high reliability DC-DC converters is operable over the full military (-55 °C to +125 °C) temperature range with no power derating. Unique to the DVSA series is a magnetic feedback circuit that is radiation immune. Operating at a nominal fixed frequency of 450 kHz, these regulated, isolated units utilize well controlled undervoltage lockout circuitry to eliminate slow start-up problems.

These converters are designed and manufactured in a facility qualified to ISO9001 and certified to MIL-PRF-38534 and MIL-STD-883.

This product may incorporate one or more of the following U.S. patents:

5,784,266
5,790,389
5,963,438
5,999,433
6,005,780
6,084,792
6,118,673

FEATURES

- High Reliability
- Very Low Output Noise
- Wide Input Voltage Range: 15 to 50 Volts per MIL-STD-704
- Up to 6 Watts Output Power
- Radiation Immune Magnetic Feedback Circuit
- NO Use of Optoisolators
- Undervoltage Lockout
- Indefinite Short Circuit Protection
- Current Limit Protection
- Industry Standard Pinout
- High Input Transient Voltage: 80 Volts for 1 sec per MIL-STD-704A
- Radiation Hardened Version Available
- Precision Projection Welded Hermetic Package
- High Power Density: > 19 W/in³
- Custom Versions Available
- Additional Environmental Screening Available
- Meets MIL-STD-461C and MIL-STD-461D EMC Requirements When Used With a DVMA28 EMI Filter
- MIL-PRF-38534 Element Evaluated Components

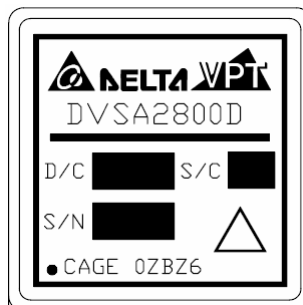

Figure 1 – DVSA2800D DC-DC Converter
(Not To Scale)

SPECIFICATIONS ($T_{CASE} = -55^{\circ}\text{C}$ to $+125^{\circ}\text{C}$, $V_{IN} = +28\text{V} \pm 5\%$, Full Load⁵, Unless Otherwise Specified)

ABSOLUTE MAXIMUM RATINGS

Input Voltage (Continuous)	50 V _{DC}	Junction Temperature Rise to Case	+10°C
Input Voltage (Transient, 1 second)	80 Volts	Storage Temperature	-65°C to +150°C
Output Power ¹	6 Watts	Lead Solder Temperature (10 seconds)	270°C
Power Dissipation (Full Load, $T_{CASE} = +125^{\circ}\text{C}$)	2.5 Watts	Weight (Maximum)	15 Grams

Parameter	Conditions	DVSA2805D			DVSA2812D			Units
		Min	Typ	Max	Min	Typ	Max	
STATIC								
INPUT Voltage ⁴	Continuous	15	28	50	15	28	50	V
	Transient, 1 sec	-	-	80	-	-	80	V
Current	Inhibited	-	-	6	-	-	6	mA
	No Load	-	30	60	-	30	60	mA
Ripple Current	Full Load ⁵ , 20Hz to 10MHz	-	30	50	-	30	50	mA _{p-p}
Inhibit Pin Input ⁴		0	-	1.5	0	-	1.5	V
Inhibit Pin Open Circuit Voltage ⁴		9.0	11.0	13.0	9.0	11.0	13.0	V
UVLO Turn On		12.0	-	14.8	12.0	-	14.8	V
UVLO Turn Off ⁴		11.0	-	14.5	11.0	-	14.5	V
OUTPUT Voltage ⁵	+V _{OUT} $T_{CASE} = 25^{\circ}\text{C}$	4.95	5.0	5.05	11.88	12.0	12.12	V
	+V _{OUT} $T_{CASE} = -55^{\circ}\text{C}$ to $+125^{\circ}\text{C}$	4.925	5.0	5.075	11.82	12.0	12.18	V
	-V _{OUT} $T_{CASE} = 25^{\circ}\text{C}$	4.80	5.0	5.20	11.80	12.0	12.20	V
	-V _{OUT} $T_{CASE} = -55^{\circ}\text{C}$ to $+125^{\circ}\text{C}$	4.75	5.0	5.25	11.52	12.0	12.48	V
Power ^{3,6}	Total	0	-	5	0	-	6	W
	$\pm V_{OUT}$ Either Output	0	-	3.5	0	-	4.2	W
Current ^{3,6}	$\pm V_{OUT}$ Either Output	0	-	0.7	0	-	0.35	A
Ripple Voltage	$\pm V_{OUT}$ Full Load ⁵ , 20Hz to 10MHz	-	-	50	-	-	50	mV _{p-p}
Line Regulation	+V _{OUT} $V_{IN} = 16\text{V}$ to 40V	-	10	20	-	10	20	mV
	-V _{OUT} $V_{IN} = 16\text{V}$ to 40V	-	50	200	-	50	200	mV
Load Regulation	+V _{OUT} No Load to Full Load ⁵	-	10	50	-	10	50	mV
	-V _{OUT} No Load to Full Load ^{5,7}	-	50	200	-	50	200	mV
Cross Regulation	-V _{OUT} +Load 70%, -Load 30% +Load 30%, -Load 70%	-	-	450	-	-	450	mV
EFFICIENCY	Full Load ⁵	66	72	-	72	77	-	%
LOAD FAULT POWER DISSIPATION	Overload ⁴	-	-	3	-	-	3	W
	Short Circuit	-	-	3	-	-	3	W
CAPACITIVE LOAD ⁴	Either Output	-	-	500	-	-	500	μF
SWITCHING FREQUENCY		350	450	500	350	450	500	kHz
ISOLATION	500 V _{DC} , $T_{CASE} = 25^{\circ}\text{C}$	100	-	-	100	-	-	M Ω
MTBF (MIL-HDBK-217F)	AIF @ $T_C = 55^{\circ}\text{C}$	-	457	-	-	457	-	kHrs

See notes next page.

SPECIFICATIONS ($T_{CASE} = -55^{\circ}\text{C}$ to $+125^{\circ}\text{C}$, $V_{IN} = +28\text{V} \pm 5\%$, Full Load⁵, Unless Otherwise Specified)

ABSOLUTE MAXIMUM RATINGS

Input Voltage (Continuous)	50 V _{DC}	Junction Temperature Rise to Case	+10°C
Input Voltage (Transient, 1 second)	80 Volts	Storage Temperature	-65°C to +150°C
Output Power ¹	6 Watts	Lead Solder Temperature (10 seconds)	270°C
Power Dissipation (Full Load, $T_{CASE} = +125^{\circ}\text{C}$)	2.5 Watts	Weight (Maximum)	15 Grams

Parameter	Conditions	DVSA2805D			DVSA2812D			Units	
		Min	Typ	Max	Min	Typ	Max		
DYNAMIC									
Load Step Output Transient	$\pm V_{OUT}$	Half Load to Full Load	-	-	300	-	-	300	mV _{PK}
Load Step Recovery ²			-	-	400	-	-	450	μSec
Line Step Output Transient ⁴	$\pm V_{OUT}$	$V_{IN} = 16\text{V}$ to 40V	-	500	1000	-	600	1200	mV _{PK}
Line Step Recovery ^{2,4}			-	300	700	-	300	500	μSec
Turn On Delay	$\pm V_{OUT}$	$V_{IN} = 0\text{V}$ to 28V	-	10	20	-	10	20	mSec
Turn On Overshoot			-	-	25	-	-	50	mV _{PK}

- Notes:
1. Dependant on output voltage.
 2. Time for output voltage to settle within 1% of its nominal value.
 3. Derate linearly to 0 at 135°C.
 4. Verified by qualification testing.
 5. Half load at +V_{OUT} and half load at -V_{OUT}.
 6. Up to 70% of the total power or current can be drawn from any one of the two outputs.
 7. 5% Load to Full Load at -55°C.

SPECIFICATIONS ($T_{CASE} = -55^{\circ}\text{C}$ to $+125^{\circ}\text{C}$, $V_{IN} = +28\text{V} \pm 5\%$, Full Load⁵, Unless Otherwise Specified)

ABSOLUTE MAXIMUM RATINGS

Input Voltage (Continuous)	50 V _{DC}	Junction Temperature Rise to Case	+10°C
Input Voltage (Transient, 1 second)	80 Volts	Storage Temperature	-65°C to +150°C
Output Power ¹	6 Watts	Lead Solder Temperature (10 seconds)	270°C
Power Dissipation (Full Load, $T_{CASE} = +125^{\circ}\text{C}$)	2.5 Watts	Weight (Maximum)	15 Grams

Parameter	Conditions	DVSA2815D			Units
		Min	Typ	Max	
STATIC					
INPUT Voltage ⁴	Continuous	15	28	50	V
	Transient, 1 sec	-	-	80	V
Current	Inhibited	-	-	6	mA
	No Load	-	30	60	mA
Ripple Current	Full Load ⁵ , 20Hz to 10MHz	-	30	50	mA _{p-p}
Inhibit Pin Input ⁴		0	-	1.5	V
Inhibit Pin Open Circuit Voltage ⁴		9.0	11.0	13.0	V
UVLO Turn On		12.0	-	14.8	V
UVLO Turn Off ⁴		11.0	-	14.5	V
OUTPUT Voltage ⁵	+V _{OUT} $T_{CASE} = 25^{\circ}\text{C}$	14.85	15.0	15.15	V
	+V _{OUT} $T_{CASE} = -55^{\circ}\text{C}$ to $+125^{\circ}\text{C}$	14.775	15.0	15.225	V
	-V _{OUT} $T_{CASE} = 25^{\circ}\text{C}$	14.80	15.0	15.20	V
	-V _{OUT} $T_{CASE} = -55^{\circ}\text{C}$ to $+125^{\circ}\text{C}$	14.40	15.0	15.60	V
Power ^{3,6}	Total	-	-	6	W
	$\pm V_{OUT}$ Either Output	-	-	4.2	W
Current ^{3,6}	$\pm V_{OUT}$ Either Output	-	-	0.28	A
Ripple Voltage	$\pm V_{OUT}$ Full Load ⁵ , 20Hz to 10MHz	-	-	50	mV _{p-p}
Line Regulation	+V _{OUT} $V_{IN} = 16\text{V}$ to 40V	-	10	20	mV
	-V _{OUT} $V_{IN} = 16\text{V}$ to 40V	-	50	200	mV
Load Regulation	+V _{OUT} No Load to Full Load ⁵	-	10	50	mV
	-V _{OUT} No Load to Full Load ^{5,7}	-	50	200	mV
Cross Regulation	-V _{OUT} +Load 70%, -Load 30% +Load 30%, -Load 70%	-	-	450	mV
EFFICIENCY	Full Load ⁵	73	79	-	%
LOAD FAULT POWER DISSIPATION	Overload ⁴	-	-	3	W
	Short Circuit	-	-	3	W
CAPACITIVE LOAD ⁴	Either Output	-	-	500	μF
SWITCHING FREQUENCY		350	450	500	kHz
ISOLATION	500 V _{DC} , $T_{CASE} = 25^{\circ}\text{C}$	100	-	-	M Ω
MTBF (MIL-HDBK-217F)	AIF @ $T_C = 55^{\circ}\text{C}$	-	457	-	kHrs

See notes next page.

SPECIFICATIONS ($T_{CASE} = -55^{\circ}\text{C}$ to $+125^{\circ}\text{C}$, $V_{IN} = +28\text{V} \pm 5\%$, Full Load⁵, Unless Otherwise Specified)

ABSOLUTE MAXIMUM RATINGS

Input Voltage (Continuous)	50 V _{DC}	Junction Temperature Rise to Case	+10°C
Input Voltage (Transient, 1 second)	80 Volts	Storage Temperature	-65°C to +150°C
Output Power ¹	6 Watts	Lead Solder Temperature (10 seconds)	270°C
Power Dissipation (Full Load, $T_{CASE} = +125^{\circ}\text{C}$)	2.5 Watts	Weight (Maximum)	15 Grams

Parameter	Conditions	DVSA2815D			Units	
		Min	Typ	Max		
DYNAMIC						
Load Step Output Transient	$\pm V_{OUT}$	Half Load to Full Load	-	-	300	mV _{PK}
Load Step Recovery ²			-	-	500	μSec
Line Step Output Transient ⁴	$\pm V_{OUT}$	$V_{IN} = 16\text{V}$ to 40V	-	500	1200	mV _{PK}
Line Step Recovery ^{2,4}			-	300	500	μSec
Turn On Delay	$\pm V_{OUT}$	$V_{IN} = 0\text{V}$ to 28V	-	10	20	mSec
Turn On Overshoot			-	-	50	mV _{PK}

- Notes:
1. Dependant on output voltage.
 2. Time for output voltage to settle within 1% of its nominal value.
 3. Derate linearly to 0 at 135°C.
 4. Verified by qualification testing.
 5. Half load at $+V_{OUT}$ and half load at $-V_{OUT}$.
 6. Up to 70% of the total power or current can be drawn from any one of the two outputs.
 7. 5% Load to Full Load at -55°C .

BLOCK DIAGRAM

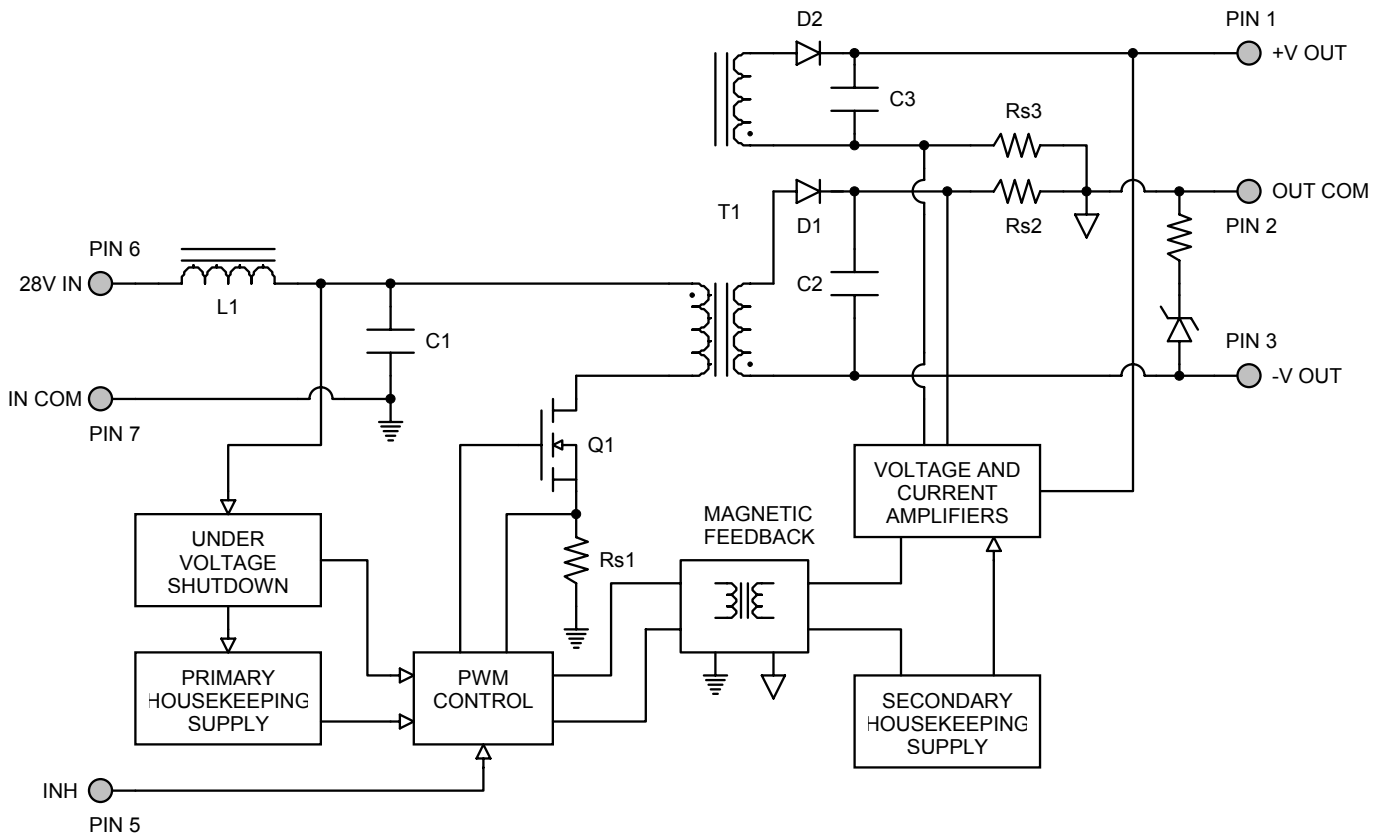

Figure 2

CONNECTION DIAGRAM

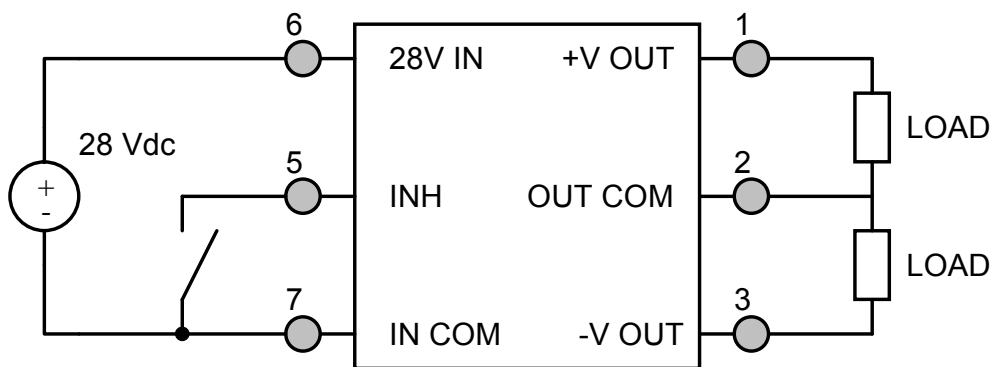

Figure 3

INHIBIT DRIVE CONNECTION DIAGRAMS

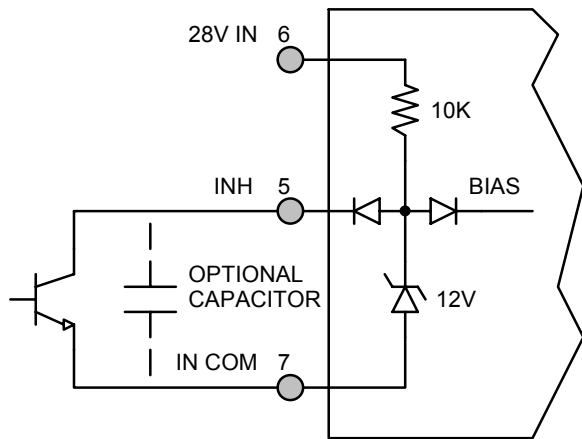

Figure 4 – Internal Inhibit Circuit and Recommended Drive
(Shown with optional capacitor for turn-on delay)

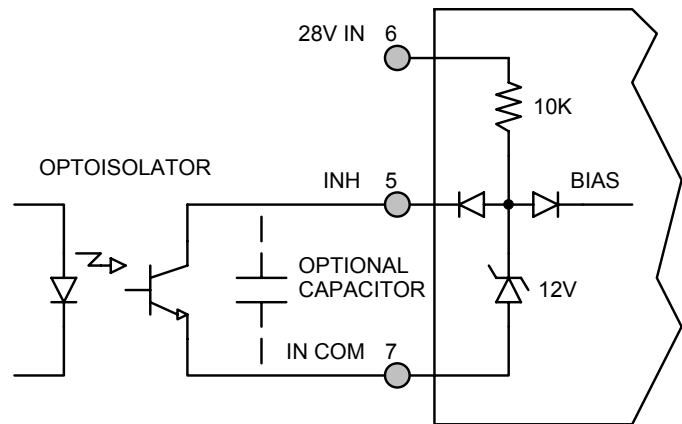

Figure 5 – Isolated Inhibit Drive
(Shown with optional capacitor for turn-on delay)

EMI FILTER HOOKUP DIAGRAM

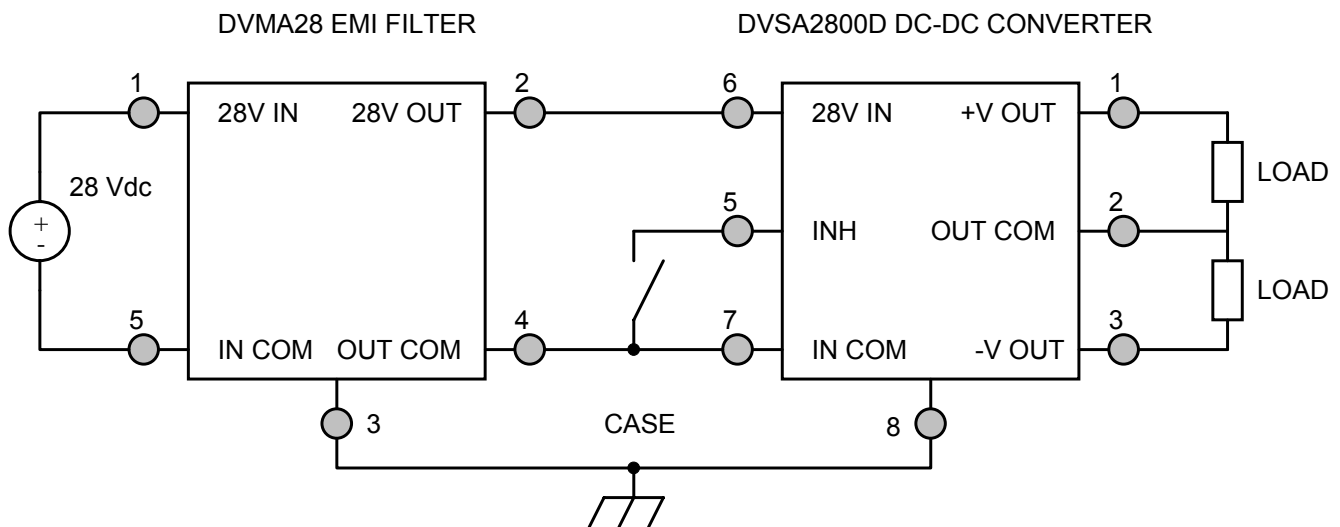

Figure 6 – Converter with EMI Filter

EFFICIENCY PERFORMANCE CURVES ($T_{CASE} = 25^{\circ}C$, Full Load, Unless Otherwise Specified)

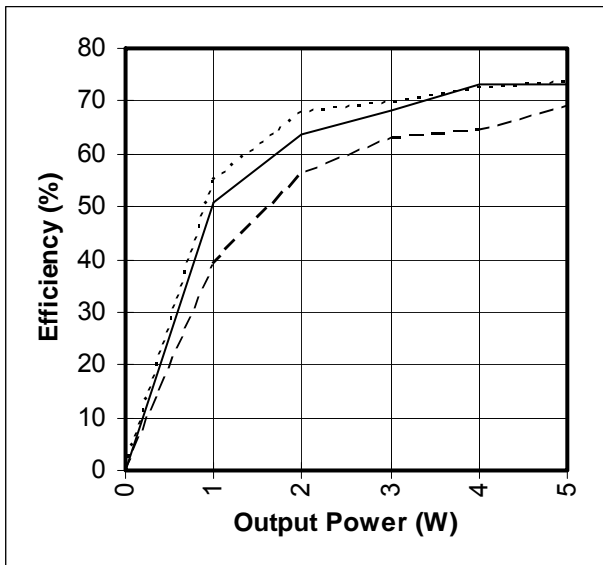
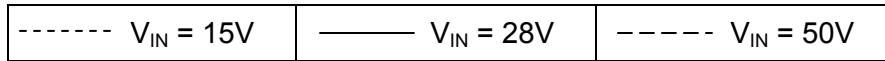

Figure 7 – DVSA2805D
Efficiency (%) vs. Output Power (W)

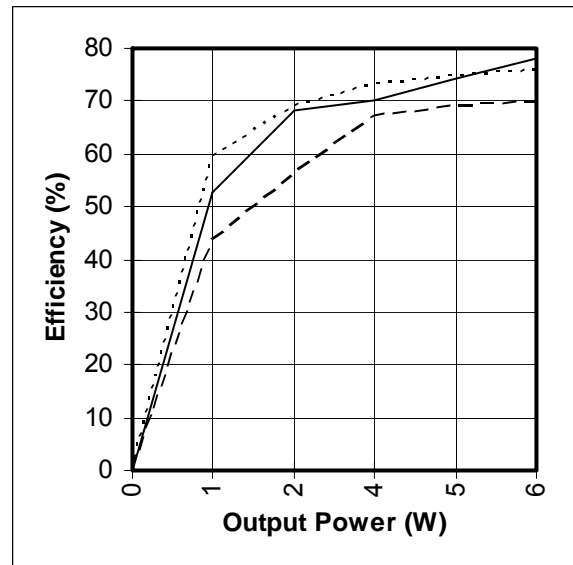

Figure 8 – DVSA2812D
Efficiency (%) vs. Output Power (W)

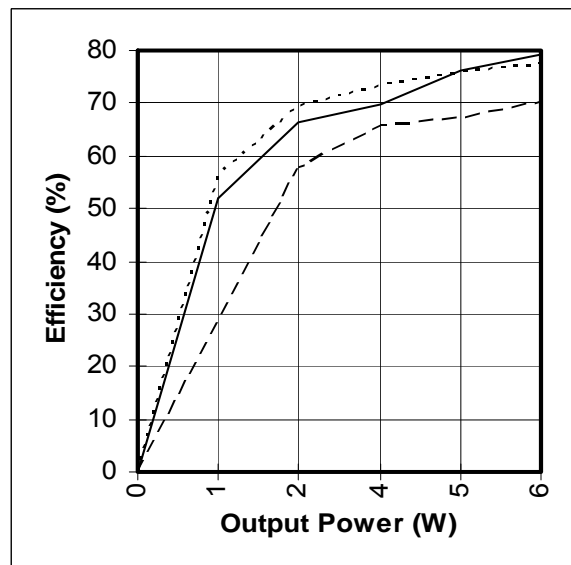

Figure 9 – DVSA2815D
Efficiency (%) vs. Output Power (W)

EMI PERFORMANCE CURVES

($T_{CASE} = 25^{\circ}C$, $V_{IN} = +28V \pm 5\%$, Full Load, Unless Otherwise Specified)

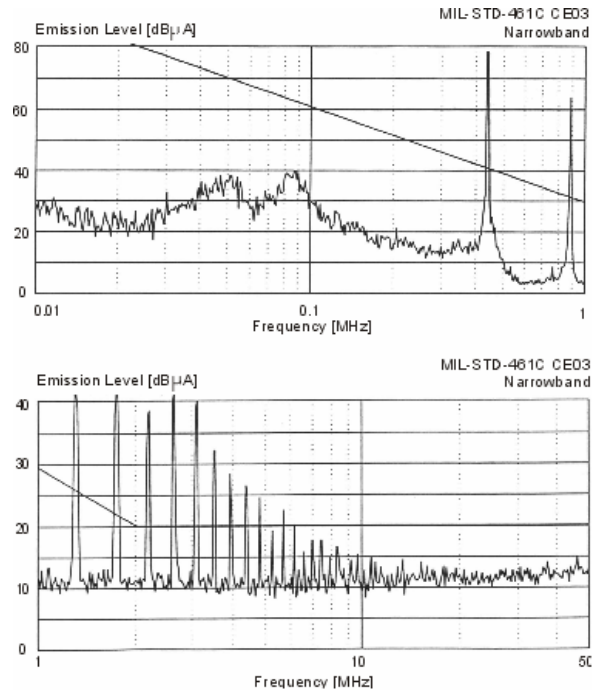

Figure 10 – DVSA2800D without EMI Filter

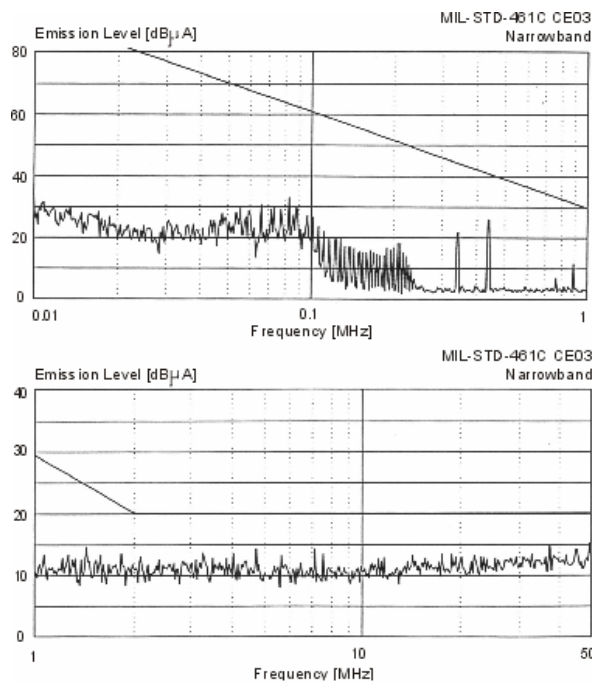
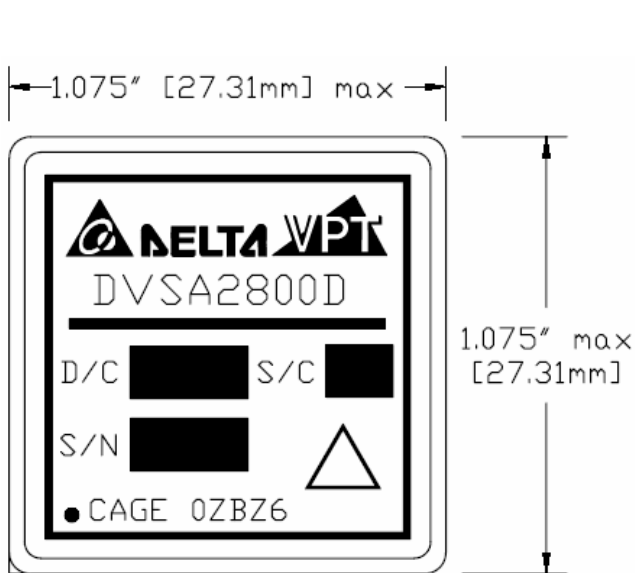
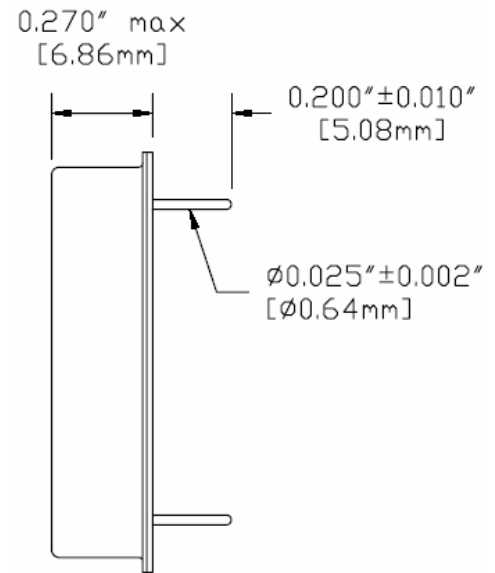

Figure 11 – DVSA2800D with EMI Filter

PACKAGE SPECIFICATIONS



TOP VIEW



SIDE VIEW

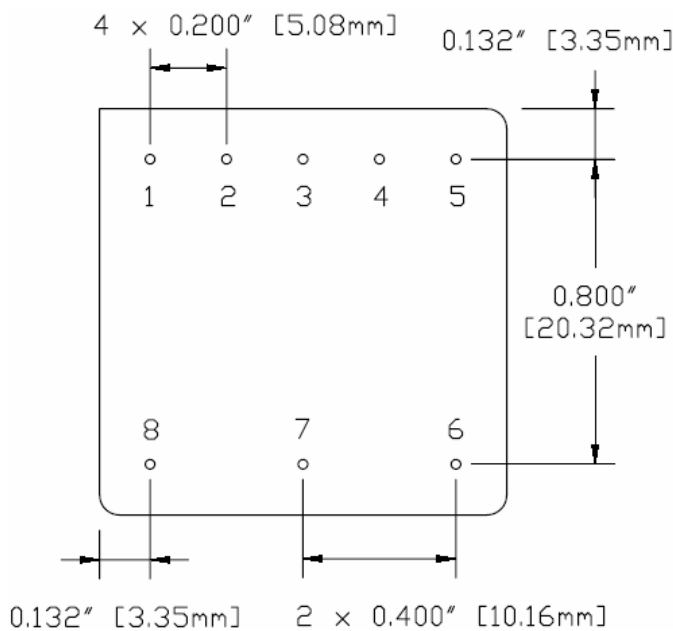

BOTTOM VIEW

PIN	FUNCTION
1	+V OUT
2	OUT COM
3	-V OUT
4	N/C
5	INHIBIT
6	28V IN
7	IN COM
8	CASE

Figure 12 – Package and Pinout
(Dimensional Limits are ± 0.005 " Unless Otherwise Stated)

PACKAGE PIN DESCRIPTION

Pin	Function	Description
1	+V OUT	Positive Output Voltage Connection
2	OUT COM	Output Common Connection
3	-V OUT	Negative Output Voltage Connection
4	N/C	No Connection
5	INHIBIT	Logic Low = Disabled Output. Connecting the inhibit pin to input common causes converter shutdown. Logic High = Enabled Output. Unconnected or open collector TTL.
6	28V IN	Positive Input Voltage Connection
7	IN COM	Input Common Connection
8	CASE	Case Connection

ENVIRONMENTAL SCREENING (100% Tested Per MIL-STD-883 as referenced to MIL-PRF-38534)

Screening	MIL-STD-883	Standard (No Suffix)	Extended /ES	HB /HB	Class H /H	Class K /K
Non-Destructive Bond Pull	Method 2023	•	•	•	•	•
Internal Visual	Method 2017, 2032 Internal Procedure	•	•	•	•	•
Temperature Cycling	Method 1010, Condition C Method 1010, -55°C to 125°C		•	•	•	•
Constant Acceleration	Method 2001, 3000g, Y1 Direction Method 2001, 500g, Y1 Direction		•	•	•	•
PIND	Method 2020, Condition A ²					•
Pre Burn-In Electrical	100% at 25°C					•
Burn-In	Method 1015, 320 hours at +125°C Method 1015, 160 hours at +125°C 96 hours at +125°C 24 hours at +125°C	•	•	•	•	•
Final Electrical	MIL-PRF-38534, Group A ¹ 100% at 25°C	•	•	•	•	•
Hermeticity	Method 1014, Fine Leak, Condition A Method 1014, Gross Leak, Condition C Dip (1 x 10 ⁻³)	•	•	•	•	•
Radiography	Method 2012 ³					•
External Visual	Method 2009	•	•	•	•	•

- Notes:
1. 100% R&R testing at -55°C, +25°C, and +125°C with all test data included in product shipment.
 2. PIND test Certificate of Compliance included in product shipment.
 3. Radiographic test Certificate of Compliance and film(s) included in product shipment.

SMD (STANDARD MICROCIRCUIT DRAWING) NUMBERS

Standard Microcircuit Drawing (SMD)	DVSA2800D Series Similar Part Number
5962-0324201HXC	DVSA2805D/H
5962-0324202HXC	DVSA2812D/H
5962-0324203HXC	DVSA2815D/H

Do not use the DVSA2800D Series similar part number for SMD product acquisition. It is listed for reference only. For exact specifications for the SMD product, refer to the SMD drawing. SMD's can be downloaded from the DSCC website at <http://www.dscclia.mil/programs/smcr/>. The SMD number listed above is for MIL-PRF-38534 Class H screening, standard gold plated lead finish, and no RHA (Radiation Hardness Assurance) level. Please reference the SMD for other screening levels, lead finishes, and radiation levels.

CONTACT INFORMATION

To request a quotation or place orders please contact your sales representative or the VPT Inc. Sales Department at:

Phone: (425) 353-3010
Fax: (425) 353-4030
E-mail: vptsales@vpt-inc.com

All information contained in this datasheet is believed to be accurate, however, no responsibility is assumed for possible errors or omissions. The products or specifications contained herein are subject to change without notice.