

## HIGH RELIABILITY HYBRID DC-DC CONVERTERS

### DESCRIPTION

The DVHV series of high reliability DC-DC converters is operable over the full military (-55 °C to +125 °C) temperature range with no power derating. Unique to the DVHV series is a magnetic feedback circuit that is radiation immune. Operating at a nominal fixed frequency of 475 kHz, these regulated, isolated units utilize well controlled undervoltage lockout circuitry to eliminate slow start-up problems. The output voltage is trimmable up to +10% or down -20%.

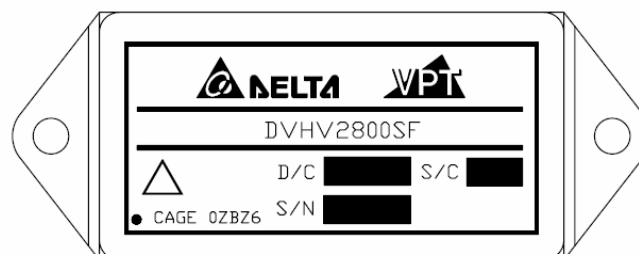
These converters are designed and manufactured in a facility qualified to ISO9001 and certified to MIL-PRF-38534 and MIL-STD-883.

This product may incorporate one or more of the following U.S. patents:

5,784,266  
5,790,389  
5,963,438  
5,999,433  
6,005,780  
6,084,792  
6,118,673

### FEATURES

- High Reliability
- Very Low Output Noise
- Output Voltage Trim Up +10% or Down -20%
- Wide Input Voltage Range: 15 to 50 Volts per MIL-STD-704
- Up to 15 Watts Output Power
- Radiation Immune Magnetic Feedback Circuit
- NO Use of Optoisolators
- Undervoltage Lockout
- Indefinite Short Circuit Protection
- Current Limit Protection
- Industry Standard Pinout
- High Input Transient Voltage: 80 Volts for 1 sec per MIL-STD-704A
- Radiation Hardened Version Available
- Precision Seam Seal or Solder Seal Hermetic Package
- Custom Versions Available
- Additional Environmental Screening Available
- Meets MIL-STD-461C and MIL-STD-461D EMC Requirements When Used With a DVMC28 EMI Filter
- Flanged and Non-flanged Versions Available.
- MIL-PRF-38534 Element Evaluated Components



**Figure 1** – DVHV2800S / DVHV2800SF DC-DC Converter  
(Not To Scale)

SPECIFICATIONS ( $T_{CASE} = -55^{\circ}\text{C}$  to  $+125^{\circ}\text{C}$ ,  $V_{IN} = +28\text{V} \pm 5\%$ , Full Load, Unless Otherwise Specified)

## ABSOLUTE MAXIMUM RATINGS

Input Voltage (Continuous)	50 $V_{DC}$	Junction Temperature Rise to Case	+15°C
Input Voltage (Transient, 1 second)	80 Volts	Storage Temperature	-65°C to +150°C
Output Power <sup>1</sup>	15 Watts	Lead Solder Temperature (10 seconds)	270°C
Power Dissipation (Full Load, $T_{CASE} = +125^{\circ}\text{C}$ )	11 Watts	Weight (Maximum) (Un-Flanged / Flanged)	(49 / 52) Grams

Parameter	Conditions	DVHV283R3S			DVHV2805S			Units
		Min	Typ	Max	Min	Typ	Max	
<b>STATIC</b>								
INPUT Voltage <sup>4</sup>	Continuous	15	28	50	15	28	50	V
	Transient, 1 sec	-	-	80	-	-	80	V
Current	Inhibited	-	-	6	-	-	6	mA
	No Load	-	-	90	-	-	90	mA
Ripple Current	Full Load, 20Hz to 10MHz	-	-	50	-	-	50	mA <sub>p-p</sub>
Inhibit Pin Input <sup>4</sup>		0	-	1.5	0	-	1.5	V
Inhibit Pin Open Circuit Voltage <sup>4</sup>		9.0	11.0	13.0	9.0	11.0	13.0	V
UVLO Turn On		12.0	-	14.8	12.0	-	14.8	V
UVLO Turn Off <sup>4</sup>		11.0	-	14.5	11.0	-	14.5	V
OUTPUT Voltage	$V_{OUT}$ $T_{CASE} = 25^{\circ}\text{C}$	3.26	3.30	3.34	4.95	5.00	5.05	V
	$V_{OUT}$ $T_{CASE} = -55^{\circ}\text{C}$ to $+125^{\circ}\text{C}$	3.25	3.30	3.35	4.925	5.00	5.075	V
Power <sup>3</sup>		0	-	10	0	-	15	W
Current <sup>3</sup>	$V_{OUT}$	0	-	3.03	0	-	3.0	A
Ripple Voltage	$V_{OUT}$ Full Load, 20Hz to 10MHz	-	-	30	-	-	30	mV <sub>p-p</sub>
Line Regulation	$V_{OUT}$ $V_{IN} = 15\text{V}$ to $50\text{V}$	-	-	20	-	-	20	mV
Load Regulation	$V_{OUT}$ No Load to Full Load	-	-	50	-	-	50	mV
EFFICIENCY		68	-	-	73	-	-	%
LOAD FAULT POWER DISSIPATION	Overload <sup>4</sup>	-	-	11	-	-	11	W
	Short Circuit	-	-	11	-	-	11	W
CAPACITIVE LOAD <sup>4</sup>		-	-	1000	-	-	1000	$\mu\text{F}$
SWITCHING FREQUENCY		400	475	550	400	475	550	kHz
SYNC FREQUENCY RANGE	$V_H - V_L = 5\text{V}$ Duty Cycle = 20% - 80%	500	-	600	500	-	600	kHz
ISOLATION	500 $V_{DC}$	100	-	-	100	-	-	M $\Omega$
MTBF (MIL-HDBK-217F)	AIF @ $T_C = 55^{\circ}\text{C}$	-	413	-	-	413	-	kHrs
<b>DYNAMIC</b>								
Load Step Output Transient	$V_{OUT}$ Half Load to Full Load	-	-	200	-	-	300	mV <sub>PK</sub>
Load Step Recovery <sup>2</sup>		-	-	550	-	-	500	$\mu\text{Sec}$
Line Step Output Transient <sup>4</sup>	$V_{OUT}$ $V_{IN} = 16\text{V}$ to $40\text{V}$	-	300	600	-	300	600	mV <sub>PK</sub>
Line Step Recovery <sup>2,4</sup>		-	300	500	-	300	500	$\mu\text{Sec}$
Turn On Delay	$V_{OUT}$ $V_{IN} = 0\text{V}$ to $28\text{V}$	-	-	20	-	-	20	mSec
Turn On Overshoot		-	-	15	-	-	25	mV <sub>PK</sub>

Notes: 1. Dependant on output voltage. 2. Time for output voltage to settle within 1% of its nominal value.  
3. Derate linearly to 0 at 135°C. 4. Verified by qualification testing.

SPECIFICATIONS ( $T_{CASE} = -55^{\circ}\text{C}$  to  $+125^{\circ}\text{C}$ ,  $V_{IN} = +28\text{V} \pm 5\%$ , Full Load, Unless Otherwise Specified)

## ABSOLUTE MAXIMUM RATINGS

Input Voltage (Continuous)	50 $V_{DC}$	Junction Temperature Rise to Case	+15°C
Input Voltage (Transient, 1 second)	80 Volts	Storage Temperature	-65°C to +150°C
Output Power <sup>1</sup>	15 Watts	Lead Solder Temperature (10 seconds)	270°C
Power Dissipation (Full Load, $T_{CASE} = +125^{\circ}\text{C}$ )	11 Watts	Weight (Maximum) (Un-Flanged / Flanged)	(49 / 52) Grams

Parameter	Conditions	DVHV2812S			DVHV2815S			Units
		Min	Typ	Max	Min	Typ	Max	
<b>STATIC</b>								
INPUT Voltage <sup>4</sup>	Continuous	15	28	50	15	28	50	V
	Transient, 1 sec	-	-	80	-	-	80	V
Current	Inhibited	-	-	6	-	-	6	mA
	No Load	-	-	90	-	-	90	mA
Ripple Current	Full Load, 20Hz to 10MHz	-	-	50	-	-	50	mA <sub>p-p</sub>
Inhibit Pin Input <sup>4</sup>		0	-	1.5	0	-	1.5	V
Inhibit Pin Open Circuit Voltage <sup>4</sup>		9.0	11.0	13.0	9.0	11.0	13.0	V
UVLO Turn On		12.0	-	14.8	12.0	-	14.8	V
UVLO Turn Off <sup>4</sup>		11.0	-	14.5	11.0	-	14.5	V
OUTPUT Voltage	$V_{OUT}$ $T_{CASE} = 25^{\circ}\text{C}$	11.88	12.0	12.12	14.85	15.0	15.15	V
	$V_{OUT}$ $T_{CASE} = -55^{\circ}\text{C}$ to $+125^{\circ}\text{C}$	11.82	12.0	12.18	14.775	15.0	15.225	V
Power <sup>3</sup>		0	-	15	0	-	15	W
Current <sup>3</sup>	$V_{OUT}$	0	-	1.25	0	-	1.0	A
Ripple Voltage	$V_{OUT}$ Full Load, 20Hz to 10MHz	-	-	40	-	-	40	mV <sub>p-p</sub>
Line Regulation	$V_{OUT}$ $V_{IN} = 15\text{V}$ to $50\text{V}$	-	-	20	-	-	20	mV
Load Regulation	$V_{OUT}$ No Load to Full Load	-	-	50	-	-	50	mV
EFFICIENCY		77	-	-	77	-	-	%
LOAD FAULT POWER DISSIPATION	Overload <sup>4</sup>	-	-	11	-	-	11	W
	Short Circuit	-	-	11	-	-	11	W
CAPACITIVE LOAD <sup>4</sup>		-	-	500	-	-	500	$\mu\text{F}$
SWITCHING FREQUENCY		400	475	550	400	475	550	kHz
SYNC FREQUENCY RANGE	$V_H - V_L = 5\text{V}$ Duty Cycle = 20% - 80%	500	-	600	500	-	600	KHz
ISOLATION	500 $V_{DC}$	100	-	-	100	-	-	M $\Omega$
MTBF (MIL-HDBK-217F)	AIF @ $T_C = 55^{\circ}\text{C}$	-	413	-	-	413	-	kHrs
<b>DYNAMIC</b>								
Load Step Output Transient	$V_{OUT}$ Half Load to Full Load	-	-	300	-	-	350	mV <sub>PK</sub>
Load Step Recovery <sup>2</sup>		-	-	550	-	-	450	$\mu\text{Sec}$
Line Step Output Transient <sup>4</sup>	$V_{OUT}$ $V_{IN} = 16\text{V}$ to $40\text{V}$	-	500	900	-	500	900	mV <sub>PK</sub>
Line Step Recovery <sup>2,4</sup>		-	300	500	-	300	500	$\mu\text{Sec}$
Turn On Delay	$V_{OUT}$ $V_{IN} = 0\text{V}$ to $28\text{V}$	-	-	20	-	-	20	mSec
Turn On Overshoot		-	-	50	-	-	50	mV <sub>PK</sub>

Notes: 1. Dependant on output voltage. 2. Time for output voltage to settle within 1% of its nominal value.  
3. Derate linearly to 0 at 135°C. 4. Verified by qualification testing.

SPECIFICATIONS ( $T_{CASE} = -55^{\circ}\text{C}$  to  $+125^{\circ}\text{C}$ ,  $V_{IN} = +28\text{V} \pm 5\%$ , Full Load, Unless Otherwise Specified)

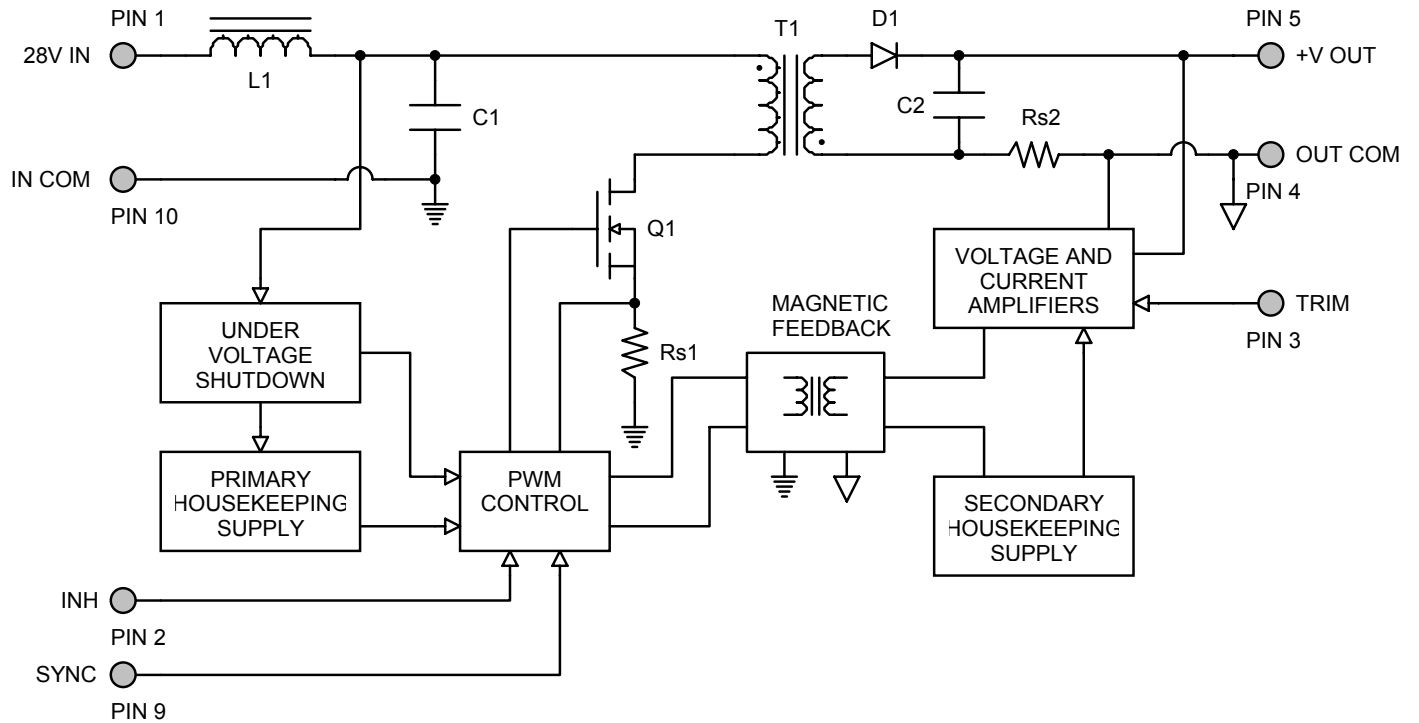
## ABSOLUTE MAXIMUM RATINGS

Input Voltage (Continuous)	50 $V_{DC}$	Junction Temperature Rise to Case	+15°C
Input Voltage (Transient, 1 second)	80 Volts	Storage Temperature	-65°C to +150°C
Output Power <sup>1</sup>	15 Watts	Lead Solder Temperature (10 seconds)	270°C
Power Dissipation (Full Load, $T_{CASE} = +125^{\circ}\text{C}$ )	11 Watts	Weight (Maximum) (Un-Flanged / Flanged)	(49 / 52) Grams

Parameter	Conditions	DVHV285R2S			Units
		Min	Typ	Max	
<b>STATIC</b>					
INPUT Voltage <sup>4</sup>	Continuous	15	28	50	V
	Transient, 1 sec	-	-	80	V
Current	Inhibited	-	-	6	mA
	No Load	-	-	90	mA
Ripple Current	Full Load, 20Hz to 10MHz	-	-	50	$\text{mA}_{p-p}$
Inhibit Pin Input <sup>4</sup>		0	-	1.5	V
Inhibit Pin Open Circuit Voltage <sup>4</sup>		9.0	11.0	13.0	V
UVLO Turn On		12.0	-	14.8	V
UVLO Turn Off <sup>4</sup>		11.0	-	14.5	V
OUTPUT Voltage	$V_{OUT}$ $T_{CASE} = 25^{\circ}\text{C}$	5.148	5.20	5.252	V
	$V_{OUT}$ $T_{CASE} = -55^{\circ}\text{C}$ to $+125^{\circ}\text{C}$	5.122	5.20	5.278	V
Power <sup>3</sup>		0	-	15	W
Current <sup>3</sup>	$V_{OUT}$	0	-	3.0	A
Ripple Voltage	$V_{OUT}$ Full Load, 20Hz to 10MHz	-	-	30	$\text{mV}_{p-p}$
Line Regulation	$V_{OUT}$ $V_{IN} = 15\text{V}$ to $50\text{V}$	-	-	20	mV
Load Regulation	$V_{OUT}$ No Load to Full Load	-	-	50	mV
EFFICIENCY		73	-	-	%
LOAD FAULT POWER DISSIPATION	Overload <sup>4</sup>	-	-	11	W
	Short Circuit	-	-	11	W
CAPACITIVE LOAD <sup>4</sup>		-	-	1000	$\mu\text{F}$
SWITCHING FREQUENCY		400	475	550	kHz
SYNC FREQUENCY RANGE	$V_H - V_L = 5\text{V}$ Duty Cycle = 20% - 80%	500	-	600	kHz
ISOLATION	500 $V_{DC}$	100	-	-	$\text{M}\Omega$
MTBF (MIL-HDBK-217F)	AIF @ $T_C = 55^{\circ}\text{C}$	-	413	-	kHrs
<b>DYNAMIC</b>					
Load Step Output Transient	$V_{OUT}$ Half Load to Full Load	-	-	300	$\text{mV}_{PK}$
Load Step Recovery <sup>2</sup>		-	-	500	$\mu\text{Sec}$
Line Step Output Transient <sup>4</sup>	$V_{OUT}$ $V_{IN} = 16\text{V}$ to $40\text{V}$	-	300	600	$\text{mV}_{PK}$
Line Step Recovery <sup>2,4</sup>		-	300	500	$\mu\text{Sec}$
Turn On Delay	$V_{OUT}$ $V_{IN} = 0\text{V}$ to $28\text{V}$	-	-	20	mSec
Turn On Overshoot		-	-	25	$\text{mV}_{PK}$

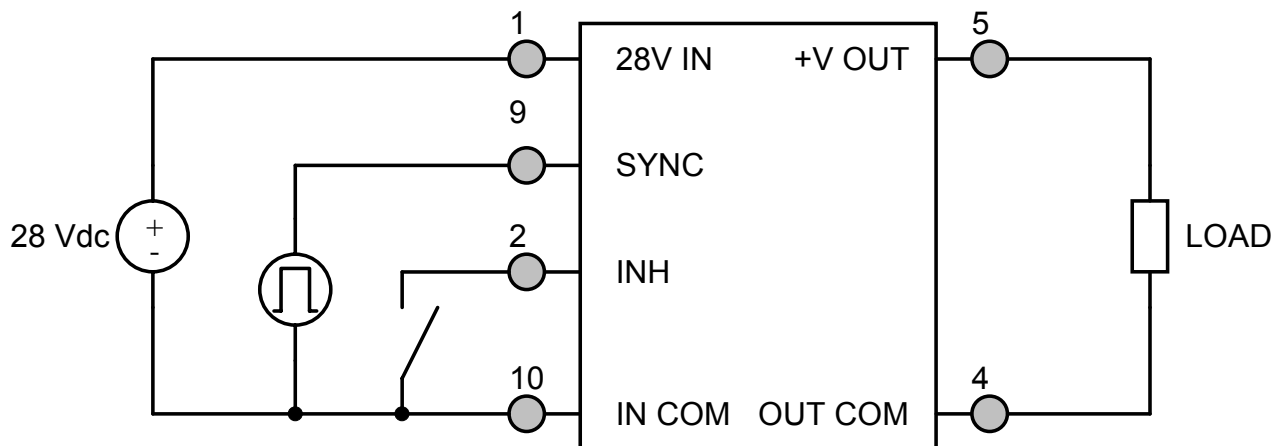
Notes: 1. Dependant on output voltage. 2. Time for output voltage to settle within 1% of its nominal value.  
3. Derate linearly to 0 at 135°C. 4. Verified by qualification testing.

**BLOCK DIAGRAM**



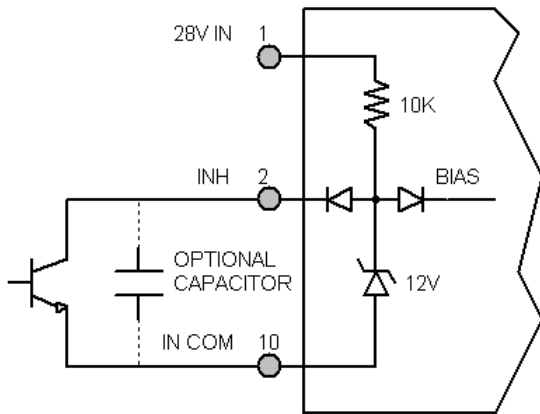
**Figure 2**

**CONNECTION DIAGRAM**

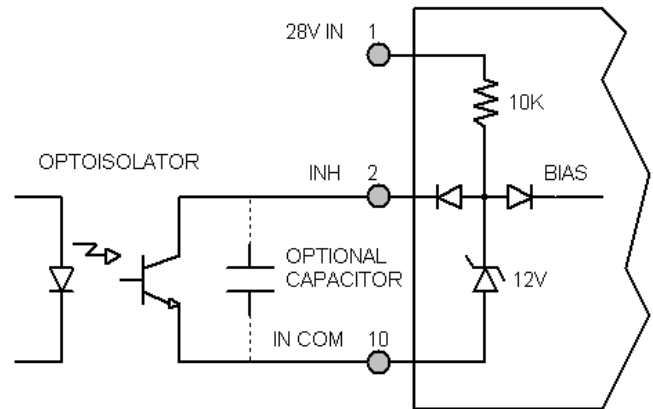


**Figure 3**

**INHIBIT DRIVE CONNECTION DIAGRAMS**

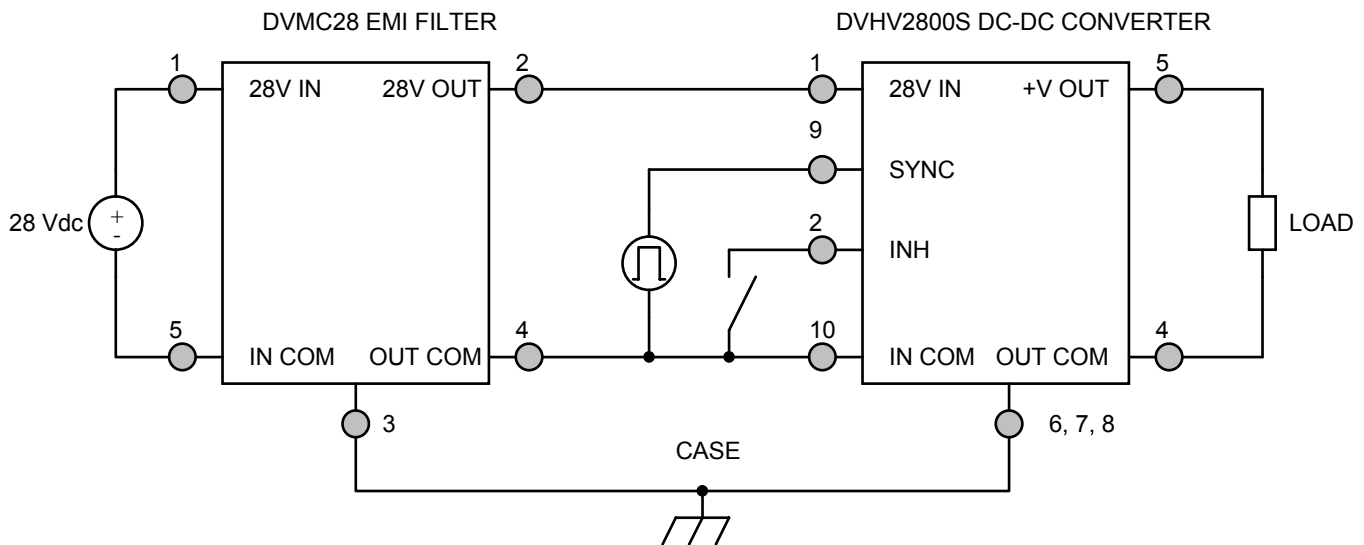


**Figure 4 – Internal Inhibit Circuit and Recommended Drive**  
(Shown with optional capacitor for turn-on delay)



**Figure 5 – Isolated Inhibit Drive**  
(Shown with optional capacitor for turn-on delay)

**EMI FILTER HOOKUP DIAGRAM**



**Figure 6 – Converter with EMI Filter**

PARALLEL CONNECTION DIAGRAM

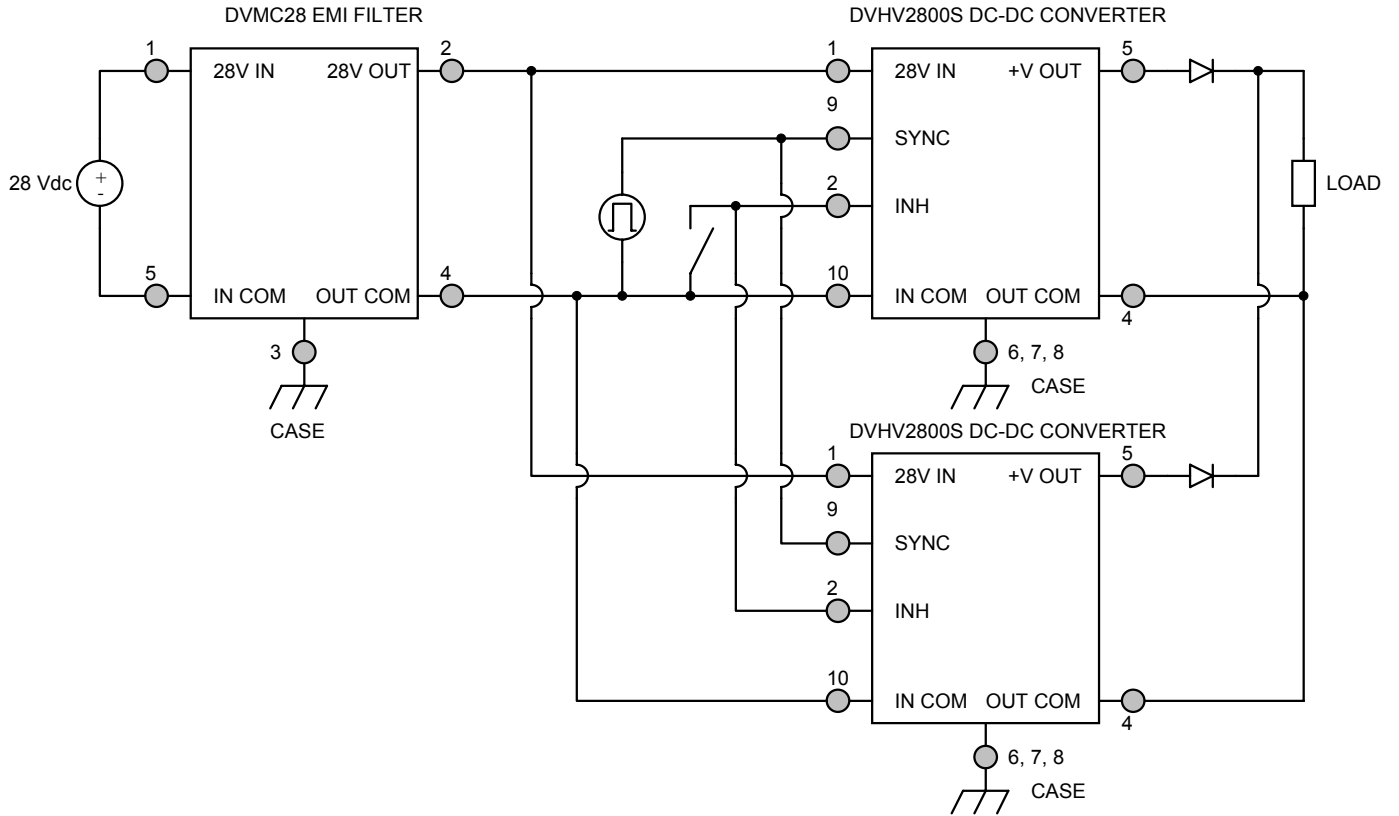
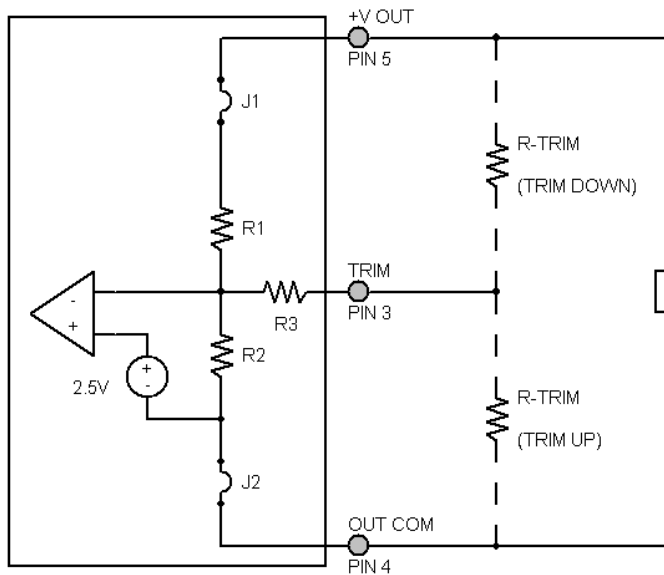


Figure 7

## OUTPUT VOLTAGE TRIM



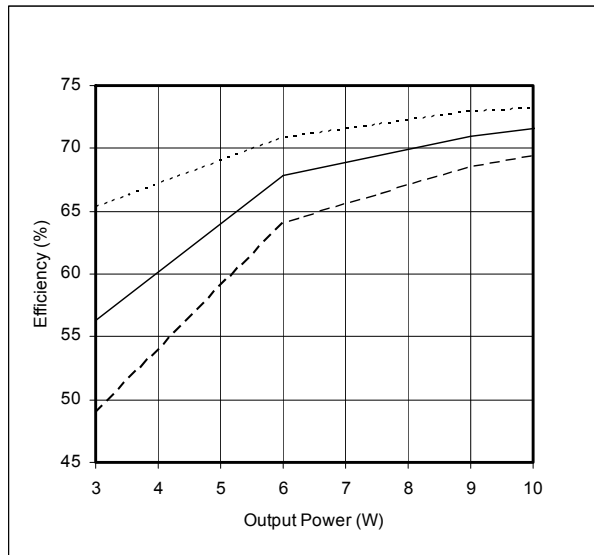
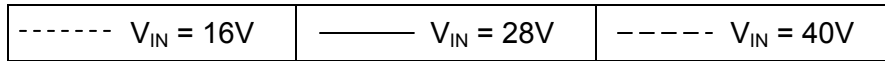
The output voltage can be trimmed down by connecting a resistor between the TRIM pin (PIN 3) and the +V OUT pin (PIN 5), or can be trimmed up by connecting a resistor between the TRIM pin (PIN 3) and the OUT COM pin (PIN 4). The maximum trim range is +10% up and -20% down. The appropriate resistor values versus the output voltage are given in the trim table below.

Figure 8 – Output Voltage Trim

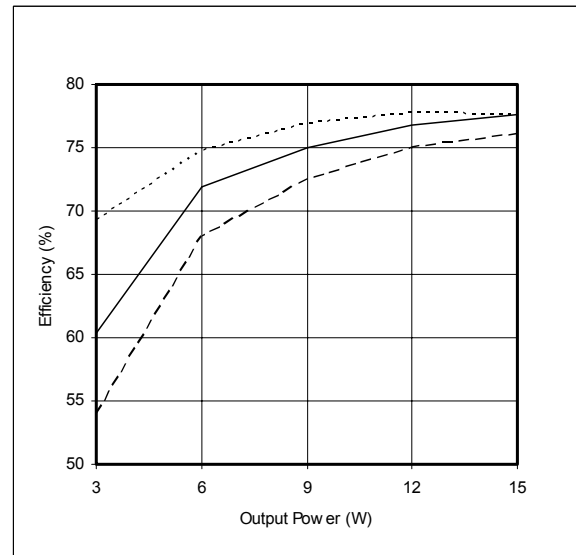
DVHV283R3S		DVHV2805S		DVHV285R2S		DVHV2812S		DVHV2815S	
+V <sub>OUT</sub> (V)	R <sub>TRIM</sub> (Ω)	+V <sub>OUT</sub> (V)	R <sub>TRIM</sub> (Ω)	+V <sub>OUT</sub> (V)	R <sub>TRIM</sub> (Ω)	+V <sub>OUT</sub> (V)	R <sub>TRIM</sub> (Ω)	+V <sub>OUT</sub> (V)	R <sub>TRIM</sub> (Ω)
3.75	25.4k	5.5	19k	5.7	23k	13.2	5.93k	16.75	0
3.70	32.5k	5.4	31.5k	5.6	36.5k	13.0	10.1k	16.50	1.67k
3.65	41.8k	5.3	52.3k	5.5	59k	12.8	16.5k	16.25	5k
3.60	54.2k	5.2	94k	5.4	104k	12.6	27.1k	16.00	10k
3.55	71.6k	5.1	219k	5.3	239k	12.4	48.4k	15.75	18.3k
3.50	98.2k	5.0	-	5.2	-	12.2	113.7k	15.50	35k
3.45	143.2k	4.9	209k	5.1	249.8k	12.0	-	15.25	85k
3.40	236k	4.8	84k	5.0	104k	11.8	437k	15.00	-
3.35	543k	4.7	42.3k	4.9	55.4k	11.6	209k	14.75	475k
3.30	-	4.6	21.5k	4.8	31.1k	11.4	132k	14.50	225k
3.25	102k	4.5	9k	4.7	16.5k	11.2	93k	14.25	142k
3.20	34.8k	4.4	0	4.6	6.8k	11.0	69.5k	14.00	100k
3.15	10.5k					10.8	53.8k	13.75	75k
3.10	0					10.6	42.6k	13.50	58.3k
						10.4	34.2k	13.25	46.4k
						10.2	27.6k	13.00	37.5k
						10.0	22.4k	12.75	30.6k
						9.8	18.1k	12.50	25k
						9.6	14.5k	12.25	20.5k
						9.4	11.5k	12.00	16.7k
						9.2	8.88k		
						9.0	6.63k		



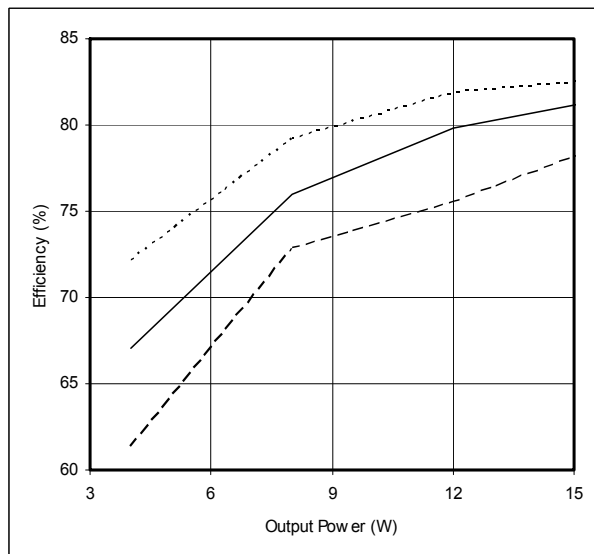
## EFFICIENCY PERFORMANCE CURVES ( $T_{CASE} = 25^{\circ}C$ , Full Load, Unless Otherwise Specified)



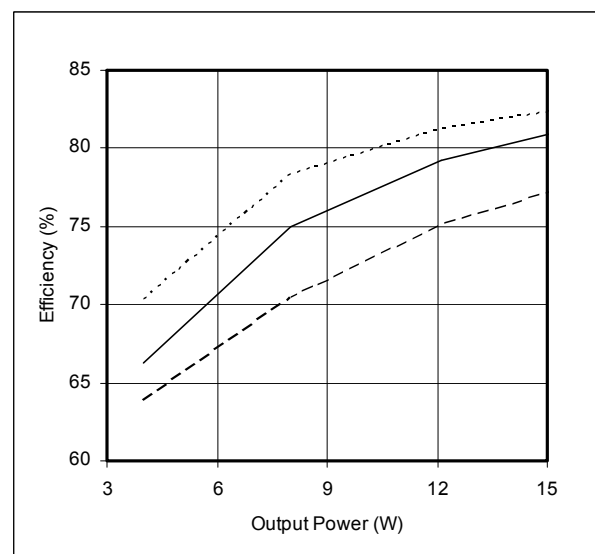
**Figure 9** – DVHV283R3S  
Efficiency (%) vs. Output Power (W)



**Figure 10** – DVHV2805S / DVHV285R2S  
Efficiency (%) vs. Output Power (W)



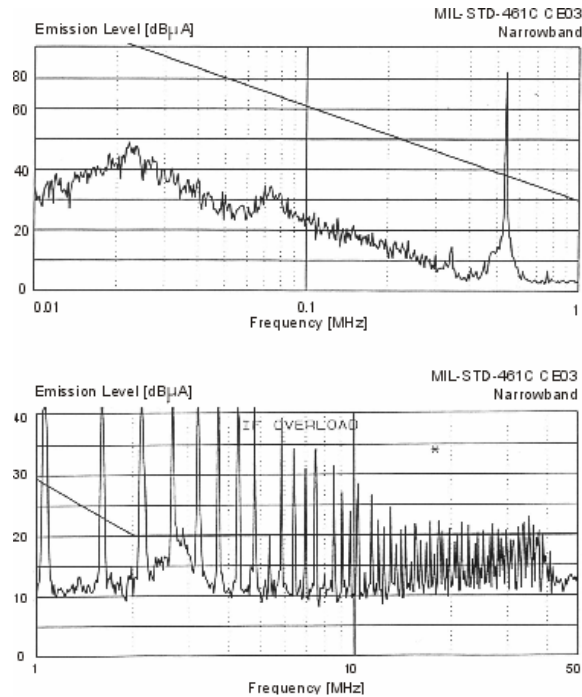
**Figure 11** – DVHV2812S  
Efficiency (%) vs. Output Power (W)



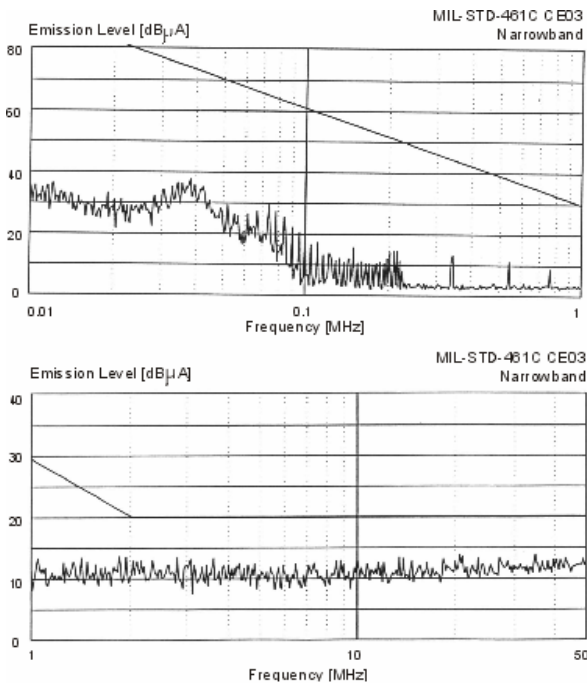
**Figure 12** – DVHV2815S  
Efficiency (%) vs. Output Power (W)

## EMI PERFORMANCE CURVES

( $T_{CASE} = 25^{\circ}C$ ,  $V_{IN} = +28V \pm 5\%$ , Full Load, Unless Otherwise Specified)

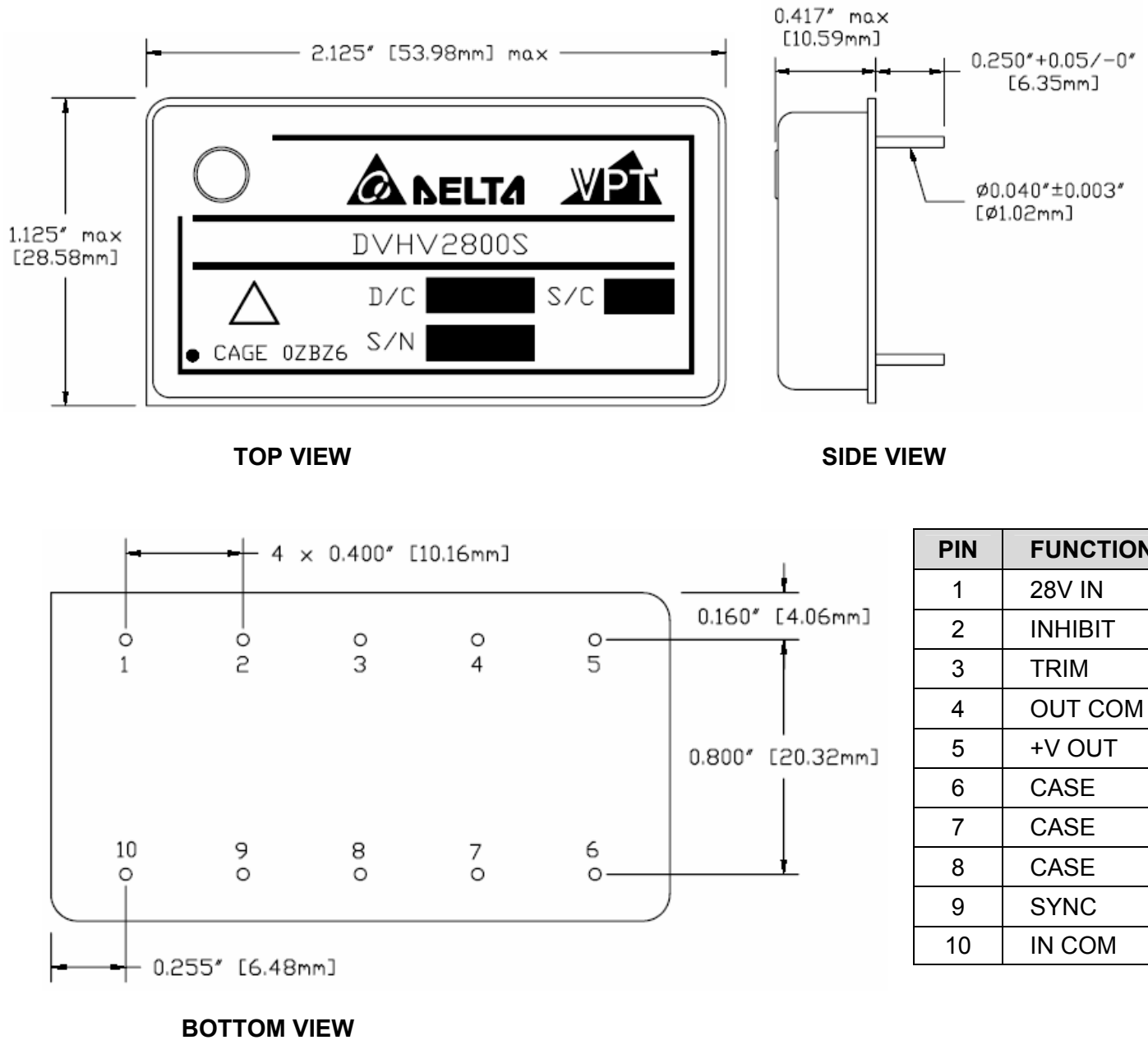


**Figure 13 – DVHV2800S without EMI Filter**



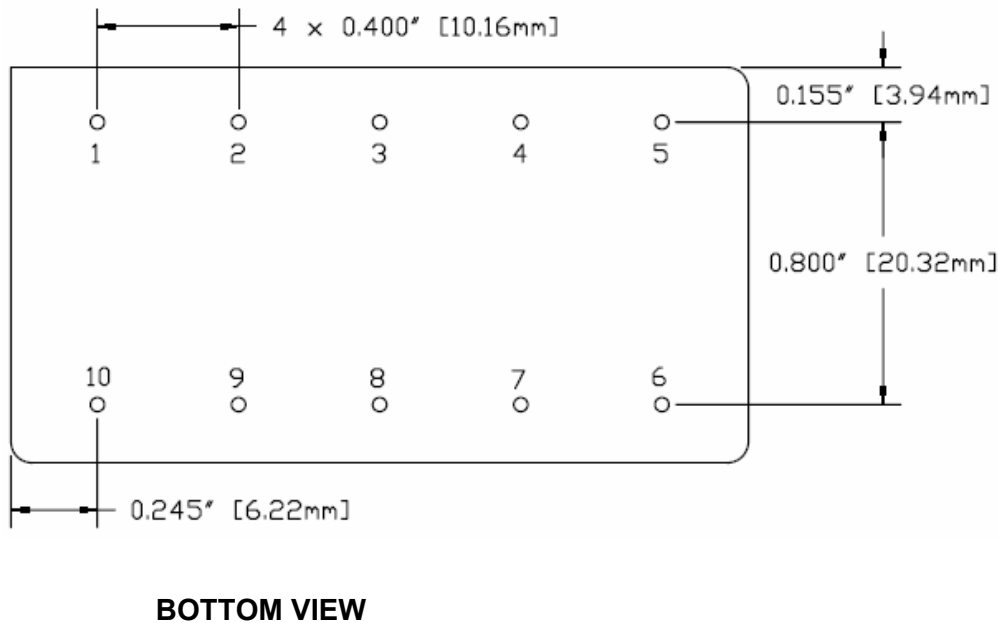
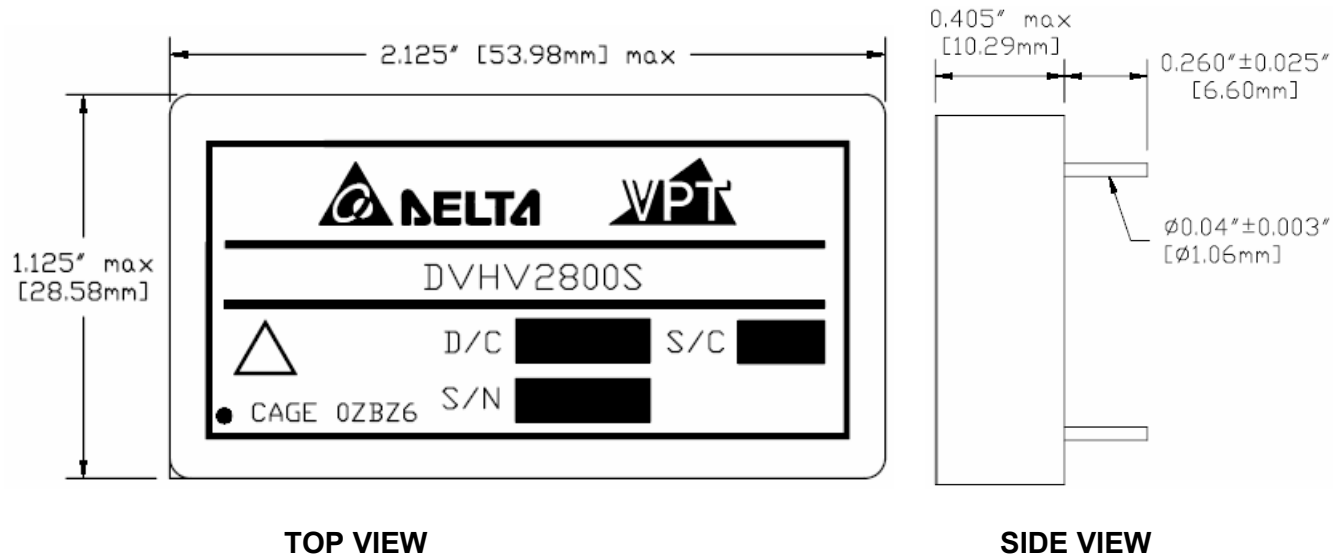
**Figure 14 – DVHV2800S with EMI Filter**

## PACKAGE SPECIFICATIONS (NON-FLANGED, SOLDER SEAL)



**Figure 15** – Non-Flanged, Solder Seal Tin Plated Package and Pinout (Not Used for /HB or Higher Screened Products)  
(Dimensional Limits are  $\pm 0.005''$  Unless Otherwise Stated)

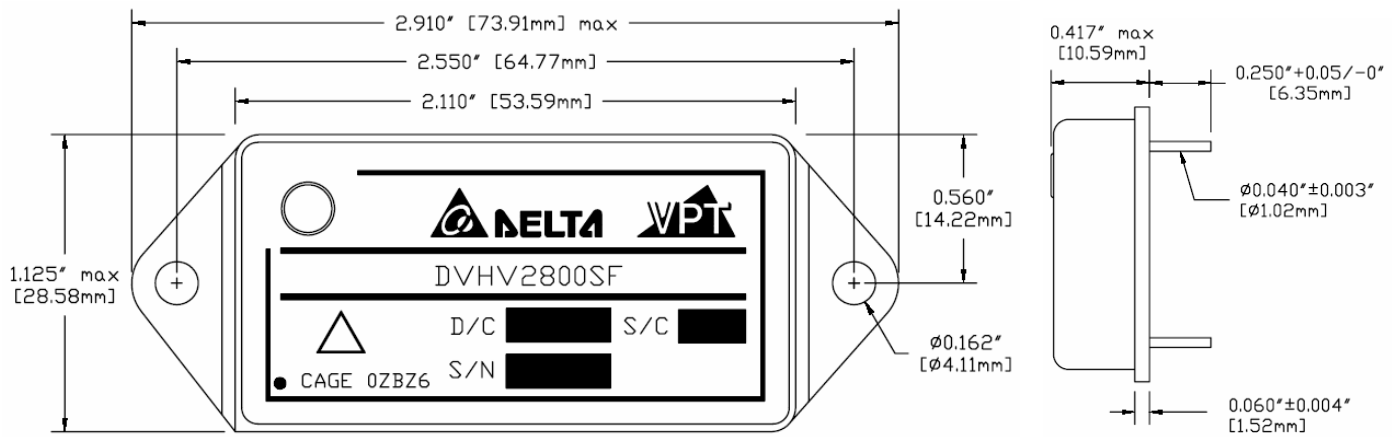
## PACKAGE SPECIFICATIONS (NON-FLANGED, SEAM SEAL)



PIN	FUNCTION
1	28V IN
2	INHIBIT
3	TRIM
4	OUT COM
5	+V OUT
6	CASE
7	CASE
8	CASE
9	SYNC
10	IN COM

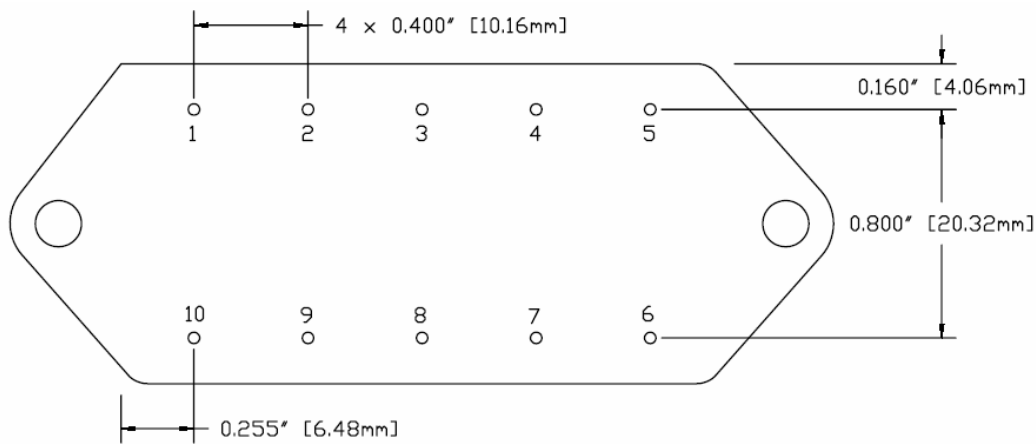
**Figure 16** – Non-Flanged, Seam Seal Package and Pinout  
(Dimensional Limits are  $\pm 0.005$ " Unless Otherwise Stated)

## PACKAGE SPECIFICATIONS (FLANGED, SOLDER SEAL)



**TOP VIEW**

**SIDE VIEW**

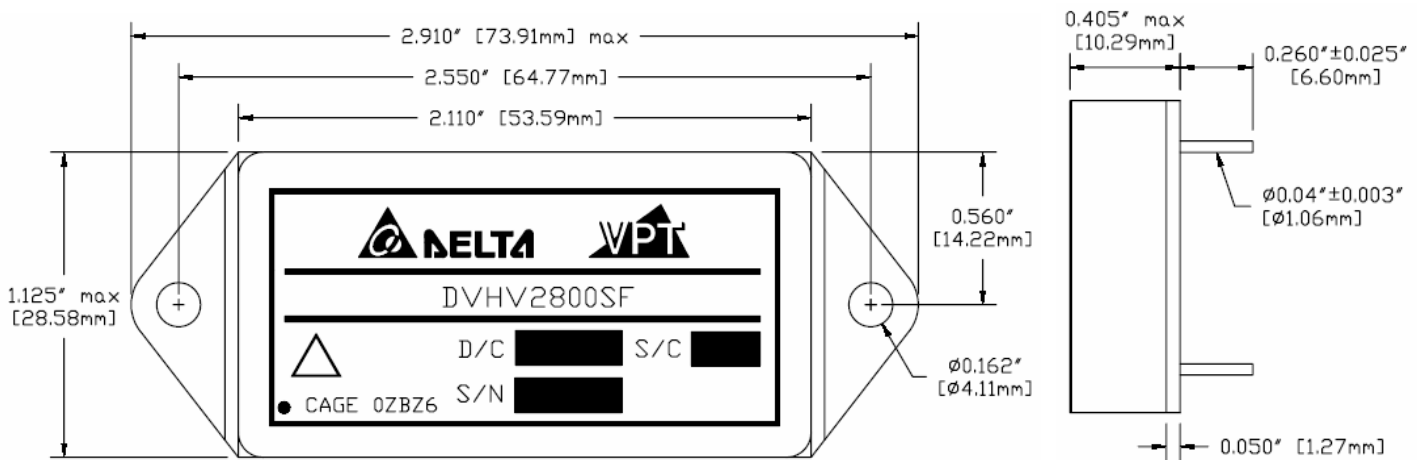


**BOTTOM VIEW**

PIN	FUNCTION
1	28V IN
2	INHIBIT
3	TRIM
4	OUT COM
5	+V OUT
6	CASE
7	CASE
8	CASE
9	SYNC
10	IN COM

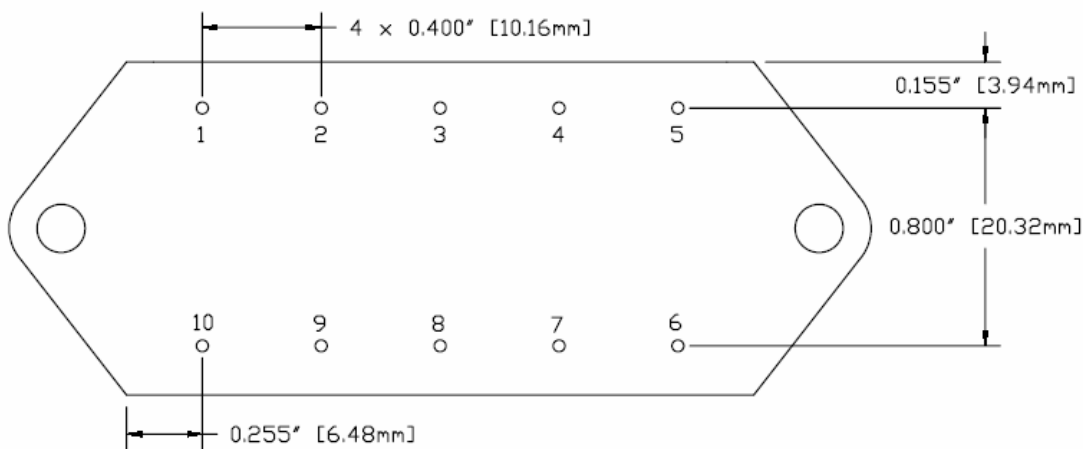
**Figure 17** – Flanged, Solder Seal Tin Plated Package and Pinout (Not Used for /HB or Higher Screened Products)  
(Dimensional Limits are ±0.005" Unless Otherwise Stated)

## PACKAGE SPECIFICATIONS (FLANGED, SEAM SEAL)



**TOP VIEW**

**SIDE VIEW**



**BOTTOM VIEW**

PIN	FUNCTION
1	28V IN
2	INHIBIT
3	TRIM
4	OUT COM
5	+V OUT
6	CASE
7	CASE
8	CASE
9	SYNC
10	IN COM

**Figure 18** – Flanged, Seam Seal Package and Pinout  
(Dimensional Limits are  $\pm 0.005$ " Unless Otherwise Stated)

## PACKAGE PIN DESCRIPTION

Pin	Function	Description
1	28V IN	Positive Input Voltage Connection
2	INHIBIT	Logic Low = Disabled Output. Connecting the inhibit pin to input common causes converter shutdown. Logic High = Enabled Output. Unconnected or open collector TTL.
3	TRIM	Trim Output Voltage to +10%, -20% of Nominal Value
4	OUT COM	Output Common Connection
5	+V OUT	Positive Output Voltage Connection
6	CASE	Case Connection
7	CASE	Case Connection
8	CASE	Case Connection
9	SYNC	Synchronization Signal
10	IN COM	Input Common Connection

## ENVIRONMENTAL SCREENING (Per MIL-STD-883 as referenced to MIL-PRF-38534, Class H)

Screening	MIL-STD-883	Standard (No Suffix)	Extended /ES	HB /HB	Class H /H	Class K /K
Non-Destructive Bond Pull	Method 2023	•	•	•	•	•
Internal Visual	Method 2017, 2032 Internal Procedure	•	•	•	•	•
Temperature Cycling	Method 1010, Condition C Method 1010, -55°C to 125°C		•	•	•	•
Constant Acceleration	Method 2001, 3000g, Y1 Direction Method 2001, 500g, Y1 Direction		•	•	•	•
PIND	Method 2020, Condition A <sup>2</sup>					•
Pre Burn-In Electrical	100% at 25°C					•
Burn-In	Method 1015, 320 hours at +125°C Method 1015, 160 hours at +125°C 96 hours at +125°C 24 hours at +125°C	•	•	•	•	•
Final Electrical	MIL-PRF-38534, Group A <sup>1</sup> 100% at 25°C	•	•	•	•	•
Hermeticity	Method 1014, Fine Leak, Condition A Method 1014, Gross Leak, Condition C Dip (1 x 10 <sup>-3</sup> )	•	•	•	•	•
Radiography	Method 2012 <sup>3</sup>					•
External Visual	Method 2009	•	•	•	•	•

- Notes:
1. 100% R&R testing at -55°C, +25°C, and +125°C with all test data included in product shipment.
  2. PIND test Certificate of Compliance included in product shipment.
  3. Radiographic test Certificate of Compliance and film(s) included in product shipment.



## ORDERING INFORMATION

<b>DVHV</b>	<b>28</b>	<b>05</b>	<b>S</b>	<b>F</b>	<b>R</b>	<b>/HB</b>	-	<b>XXX</b>
1	2	3	4	5	6	7		8

(1) Product Series	(2) Nominal Input Voltage		(3) Output Voltage		(4) Number of Outputs	
<b>DVHV</b>	<b>28</b>	28 Volts	<b>3R3</b> <b>05</b> <b>5R2</b> <b>12</b> <b>15</b>	3.3 Volts 5 Volts 5.2 Volts 12 Volts 15 Volts	<b>S</b>	Single

(5) Package Option		(6) Rad-Hard Option <sup>2</sup>		(7) Screening Code <sup>1,3</sup>		(8) Additional Screening Code
<b>None</b> <b>F</b>	Non-Flanged Flanged	<b>None</b> <b>R</b>	Standard 100 kRad	<b>None</b> <b>/ES</b> <b>/HB</b> <b>/H</b> <b>/K</b>	Standard Extended HB Class H Class K	Contact Sales

- Notes:
1. Contact the VPT Inc. Sales Department for availability of Class H (/H) or Class K (/K) qualified products.
  2. VPT Inc. is not currently qualified to a DSCC certified radiation hardness assurance program.
  3. VPT Inc. reserves the right to ship higher screened or SMD products to meet lower screened orders at our sole discretion unless specifically forbidden by customer contract.

Please contact your sales representative or the VPT Inc. Sales Department for more information concerning additional environmental screening and testing, different input voltage, output voltage, power requirement, source inspection, and/or special element evaluation for space or other higher quality applications.

## SMD (STANDARD MICROCIRCUIT DRAWING) NUMBERS

Standard Microcircuit Drawing (SMD)	DVHV2800S Series Similar Part Number
*T.B.D.	DVHV283R3S/H DVHV283R3SF/H
*T.B.D.	DVHV2805S/H DVHV2805SF/H
*T.B.D.	DVHV285R2S/H DVHV285R2SF/H
*T.B.D.	DVHV2812S/H DVHV2812SF/H
*T.B.D.	DVHV2815S/H DVHV2815SF/H

Do not use the DVHV2800S Series similar part number for SMD product acquisition. It is listed for reference only. For exact specifications for the SMD product, refer to the SMD drawing. SMD's can be downloaded from the DSCC website at <http://www.dsccl.dla.mil/programs/smcr/>. The SMD number listed above is for MIL-PRF-38534 Class H screening, standard gold plated lead finish, and no RHA (Radiation Hardness Assurance) level. Please reference the SMD for other screening levels, lead finishes, and radiation levels.

## CONTACT INFORMATION

To request a quotation or place orders please contact your sales representative or the VPT Inc. Sales Department at:

**Phone:** (425) 353-3010  
**Fax:** (425) 353-4030  
**E-mail:** [vptsales@vpt-inc.com](mailto:vptsales@vpt-inc.com)

All information contained in this datasheet is believed to be accurate, however, no responsibility is assumed for possible errors or omissions. The products or specifications contained herein are subject to change without notice.