

OBSOLETE PRODUCT
NO RECOMMENDED REPLACEMENT
contact our Technical Support Center at
1-888-INTERSIL or www.intersil.com/tsc

August 21, 1998

FN7294

Programmable CPU Power Supply Unit

élantec

The EL7560 is the simplest, most cost effective method for powering modern high power CPUs which require a user adjustable output voltage. Although it is particularly designed to function with next generation CPUs, its simple design can provide low cost solutions for any 5V to 3V application.

The circuit uses on chip resistorless current sensing for high efficiency, stable current mode control. An on chip temperature sensor resets the OT pin. The OT pin can be tied directly to the OUTEN pin for automatic overtemperature shutdown. The user can adjust the oscillator frequency as well as the slope compensation.

The output voltage is adjustable using a 4-bit parallel interface. A power OK signal "PWRGD" pulls high when the FB pin is within -7% of the programmed value.

Pinout

EL7560
(28-PIN SOIC)
TOP VIEW

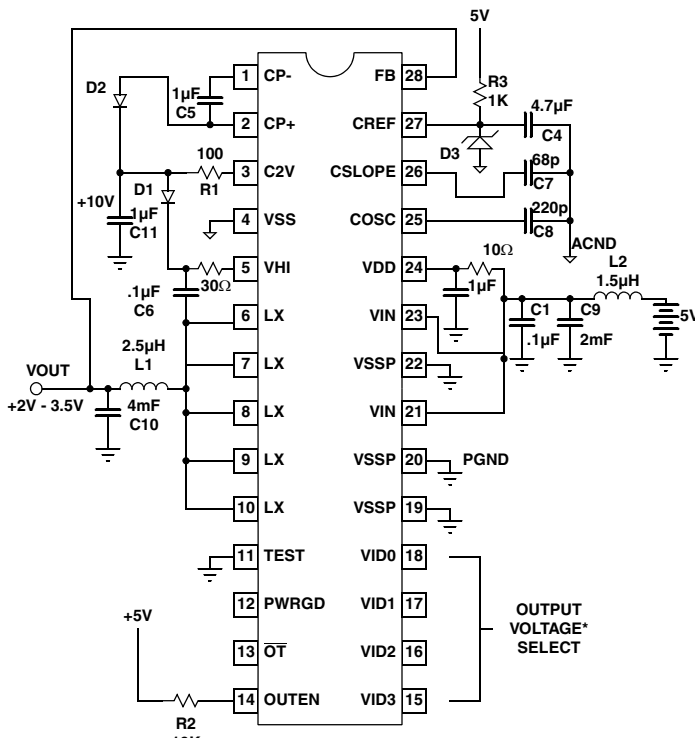

* See VID Table on page 3
Note:
• AGND and PGND should be connected at C10
• D3 is 1.235V reference.

Features

- 3.3V @ 12.4amps continuous
- Internal FETs
- >90% efficiency
- Synchronous switching
- 4-bit digitally adjustable output voltage
- User adjustable slope compensation
- Internal soft start
- Over temperature indicator
- Low current sleep mode
- Low parts count
- Pulse by pulse current limiting
- High efficiency at light load
- Operates up to 1MHz
- 1% output accuracy
- Sync function
- Power good signal

Applications

- PC motherboards
- Local high power CPU supplies

Ordering Information

PART NUMBER	TEMP. RANGE	PACKAGE	PKG. NO.
EL7560CM	-40°C to +85°C	28-Pin SOIC	MDP0027

Absolute Maximum Ratings ($T_A = 25^\circ\text{C}$)

Supply (V_{IN}, V_{DD}) 5.5V
 Output Pins -0.3V below GND, +0.3V above V_{DD}
 Instantaneous Peak Output Current 16A
 Storage Temperature Range -65°C to +150°C

Ambient Operating Temperature -40°C to +85°C
 Operating Junction Temperature 135°C
 Power Dissipation 3W

CAUTION: Stresses above those listed in "Absolute Maximum Ratings" may cause permanent damage to the device. This is a stress only rating and operation of the device at these or any other conditions above those indicated in the operational sections of this specification is not implied.

IMPORTANT NOTE: All parameters having Min/Max specifications are guaranteed. Typical values are for information purposes only. Unless otherwise noted, all tests are at the specified temperature and are pulsed tests, therefore: $T_J = T_C = T_A$

DC Electrical Specifications $V_{DD} = V_{IN} = 5V, C_{OSC} = 1nF, C_{SLOPE} = 68pF, T_A = 25^\circ\text{C}$, unless otherwise specified (Note 1)

PARAMETER	DESCRIPTION	CONDITION	MIN	TYP	MAX	UNITS
V_{2X}	Voltage Doubler Output	$V_{DD}=5V, I_{LOAD}=20mA$	8.0	9	9.5	V
DAC_{LSB}	DAC Resolution		0.095		0.105	V
F_{OSC}	Oscillator Initial Accuracy		105	120	135	kHz
F_{OSCTC}	Oscillator Tempco	$0^\circ\text{C} < T_A < 125^\circ\text{C}$		± 0.1		%/°C
V_{RAMP}	Oscillator Ramp Amplitude			1.2		V
M_{SS}	Soft Start Slope	$F_{OSC}=500kHz$		0.3		V/msec
I_{VID}	VID Pull Up Current	$VID = 0V$	9	13	18	μA
I_{CSLOPE}	C_{SLOPE} Charging Current		32	40	48	μA
I_{DD}	Supply Current	$OUTEN=4V, F_{OSC}=120kHz$		25	35	mA
I_{DDOFF}	Stdby Current	$OUTEN=0V$		3	5	mA
R_{DSON}	Composite FET Resistance		18		25	$m\Omega$
R_{DSONTC}	R_{DSON} Tempco			0.1		$m\Omega/^\circ\text{C}$
V_{OUT}	Output Initial Accuracy	$VID=0111$	2.765	2.8	2.835	V
V_{RANGE}	Output Voltage Range	$VID=1110$ to 0000	2.065		3.535	V
I_{LMAX}	Maximum current	$V_{OUT}=0$		14.0		amps
V_{OUT-TC}	Output Tempco	$0^\circ\text{C} < T_A < 70^\circ\text{C}$		± 1		%
$V_{OUT-LINE}$	Output Line Regulation	$V_{OUT}=2.8, 4.5V_{DD}<5.5, V_{DD}=V_{IN}$	-1		1	%
$V_{OUT-LOAD}$	Output Load Regulation	$0.3A < I_{LOAD} < 12.4A$	-1		1	%
$V_{OUT-TOT}$	Output Total Variation		-2		2	%
OT_{OFF}	Over Temperature Threshold			135		°C
OT_{HYS}	Over Temperature Hysteresis			50		°C
V_{PWRGD}	Power Good Threshold with Respect to Desired Output Voltage	$VID=0111$	-9	-7	-5	%
V_{DD-ON}	Minimum V_{DD} form Startup				4	V
V_{DD-OFF}	Maximum V_{DD} for Shutdown		3.75			V

NOTE:

1. The oscillator and voltage doubler operate normally when V_{DD} exceeds V_{DD-ON} threshold, independent of the $OUTEN$ logic level.

Voltage Identification Codes

P6 PINS			V _{ID0}	V _{DC}
V _{ID3}	V _{ID2}	V _{ID1}		
1	1	1	1	0, No CPU
1	1	1	0	2.1
1	1	0	1	2.2
1	1	0	0	2.3
1	0	1	1	2.4
1	0	1	0	2.5
1	0	0	1	2.6
1	0	0	0	2.7
0	1	1	1	2.8
0	1	1	0	2.9
0	1	0	1	3.0
0	1	0	0	3.1
0	0	1	1	3.2
0	0	1	0	3.3
0	0	0	1	3.4
0	0	0	0	3.5

EL7560 Pin Descriptions

PIN NUMBER	NAME	DESCRIPTION
1	C _{P-}	Negative input for the charge pump bootstrap capacitor. (Note 1)
2	C _{P+}	Positive input for the charge pump bootstrap capacitor. (Note 1)
3	C2V	Voltage doubler output. Pin requires at least a 1μF capacitor to GND. (Note 1)
4	V _{SS}	Ground return for the control circuitry.
5	V _{HI}	Positive supply for the high side driver. This pin is bootstrapped from the LX pin with a 0.1μF capacitor.
6	LX	Common connection between the two large internal FETs. External inductor connection.
7	LX	Same as pin 6.
8	LX	Same as pin 6.
9	LX	Same as pin 6.
10	LX	Same as pin 6.
11	TEST	This is test pin and must remain grounded at all times
12	PWRGD	Pin pulls high when the FB pin is within - 7%(typ) of its programmed value.
13	$\overline{\text{OT}}$	Overtemperature indicator. Pulls low when the die temperature exceeds 135°C. Pin has 10mA pull-up.
14	$\overline{\text{OT}}$	A logic high on OUTEN enables the regulator (Note 1)
15	VID3	Bit 3(MSB) of the output voltage select DAC.
16	VID2	Bit 2 of the output voltage select DAC.
17	VID1	Bit 1 of the output voltage select DAC.
18	VID0	Bit 0(LSB) of the output voltage select DAC.
19	V _{SSP}	Ground return to the buck regulator.
20	V _{SSP}	Same as pin 19.
21	V _{IN}	Positive power supply input to the buck regulator.
22	V _{SSP}	Same as pin 19.
23	V _{IN}	Same as pin 21.
24	V _{DD}	Pin supplies power to the internal control circuitry.
25	C _{OSC}	Oscillator timing capacitor. Oscillator Frequency is approximately: F _{OSC} (Hz)=0.0001/C _{OSC} (F). The duty cycle is approximately 5%. (Note 1)
26	C _{SLOPE}	Slope compensation capacitor.
27	C _{REF}	External reference input pin.
28	FB	Voltage feedback pin for the buck regulator.

NOTE:

1. The oscillator and voltage doubler operate normally when V_{DD} exceeds V_{DD-ON} threshold, independent of the OUTEN logic level.

Typical Performance Curves

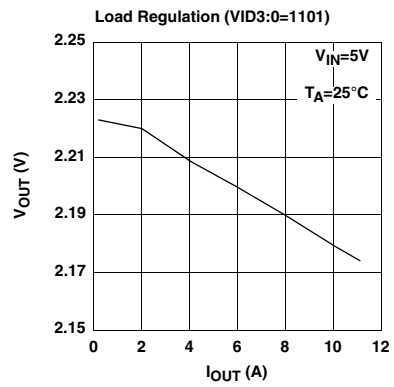
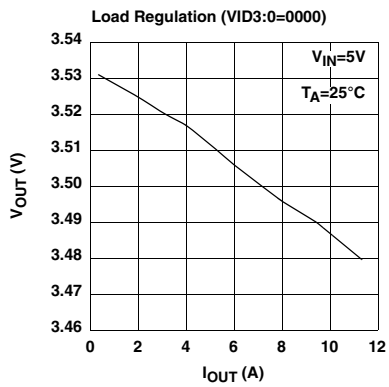
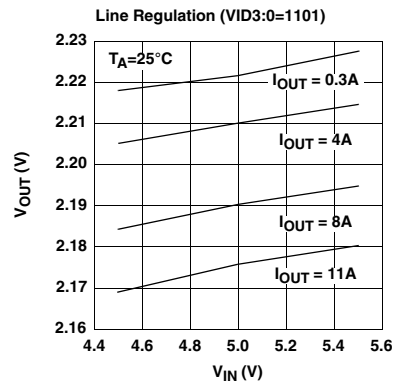
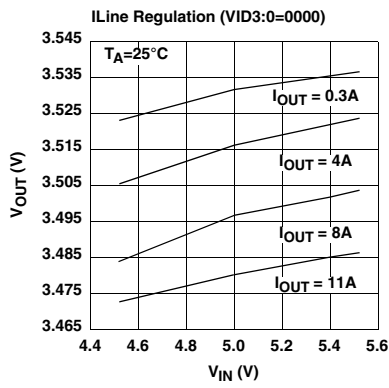
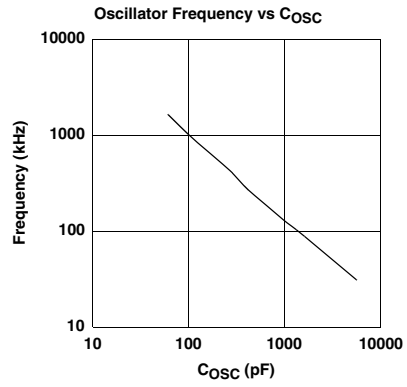
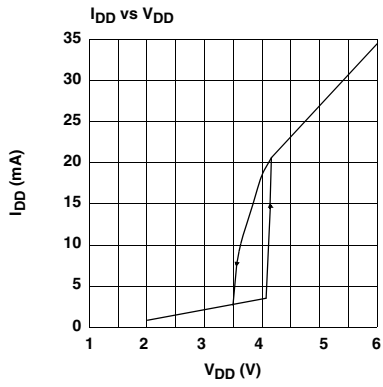

Typical Performance Curves (Continued)

