



Integrated Device Technology, Inc.

## 3.3V CMOS OCTAL D REGISTERS (3-STATE)

IDT54/74FCT3574/A  
ADVANCE INFORMATION

### FEATURES:

- 0.5 MICRON CMOS Technology
- ESD > 2000V per MIL-STD-883, Method 3015; > 200V using machine model (C = 200pF, R = 0)
- 25 mil Center SSOP Packages
- Extended commercial range of -40°C to +85°C
- VCC = 3.3V ±0.3V, Normal Range or VCC = 2.7V to 3.6V, Extended Range
- CMOS power levels (0.4µW typ. static)
- Rail-to-Rail output swing for increased noise margin
- Military product compliant to MIL-STD-883, Class B

### DESCRIPTION:

The FCT3574/A are 8-bit registers built using an advanced dual metal CMOS technology. These registers consist of eight D-type flip-flops with a buffered common clock and buffered 3-state output control. When the output ( $\overline{OE}$ ) input is LOW, the eight outputs are enabled. When the  $\overline{OE}$  input is HIGH, the outputs are in the high-impedance state.

Input data meeting the set-up and hold time requirements of the D inputs is transferred to the O outputs on the LOW-to-HIGH transition of the clock input.

### FUNCTIONAL BLOCK DIAGRAM

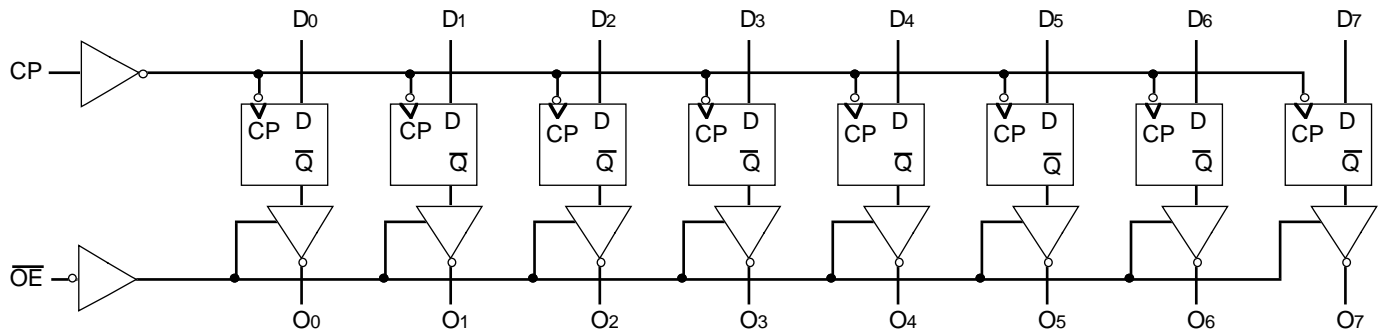

3095 drw 01

### PIN CONFIGURATION

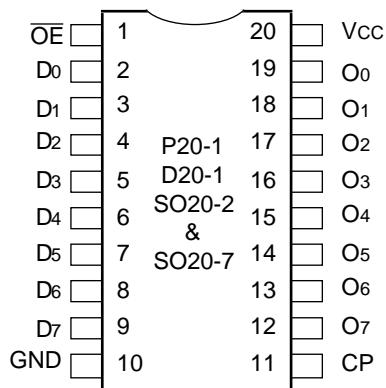

DIP/SOIC/SSOP  
TOP VIEW

3095 drw 02

### PIN DESCRIPTION

Pin Names	Description
DN	D flip-flop data inputs
CP	Clock Pulse for the register. Enters data on LOW-to-HIGH transition.
ON	3-state outputs, (true)
$\overline{ON}$	3-state outputs, (inverted)
$\overline{OE}$	Active LOW 3-state Output Enable input

3095 tbl 01

The IDT logo is a registered trademark of Integrated Device Technology, Inc.

**MILITARY AND COMMERCIAL TEMPERATURE RANGES**

**AUGUST 1995**

**FUNCTION TABLE (1)**

Function	Inputs			Outputs	Internal
	$\overline{OE}$	CP	DN	ON	$\overline{QN}$
HI-Z	H	L	X	Z	NC
	H	H	X	Z	NC
LOAD REGISTER	L	↑	L	L	H
	L	↑	H	H	L
	H	↑	L	Z	H
	H	↑	H	Z	L

**NOTE:**

3095 tbl 02

- H = HIGH Voltage Level  
L = LOW Voltage Level  
X = Don't Care  
Z = High Impedance  
NC = No Change  
↑ = LOW-to-HIGH transition

**ABSOLUTE MAXIMUM RATINGS(1)**

Symbol	Rating	Commercial	Military	Unit
VTERM(2)	Terminal Voltage with Respect to GND	-0.5 to +4.6	-0.5 to +4.6	V
VTERM(3)	Terminal Voltage with Respect to GND	-0.5 to +7.0	-0.5 to +7.0	V
VTERM(4)	Terminal Voltage with Respect to GND	-0.5 to Vcc + 0.5	-0.5 to Vcc + 0.5	V
TA	Operating Temperature	-40 to +85	-55 to +125	°C
TBIAS	Temperature Under Bias	-55 to +125	-65 to +135	°C
TSTG	Storage Temperature	-55 to +125	-65 to +150	°C
PT	Power Dissipation	1.0	1.0	W
IOUT	DC Output Current	-60 to +60	-60 to +60	mA

**NOTES:**

3095 lmk 03

- Stresses greater than those listed under ABSOLUTE MAXIMUM RATINGS may cause permanent damage to the device. This is a stress rating only and functional operation of the device at these or any other conditions above those indicated in the operational sections of this specification is not implied. Exposure to absolute maximum rating conditions for extended periods may affect reliability.
- Vcc terminals.
- Input terminals.
- Output and I/O terminals.

**CAPACITANCE (TA = +25°C, f = 1.0MHz)**

Symbol	Parameter(1)	Conditions	Typ.	Max.	Unit
CIN	Input Capacitance	VIN = 0V	3.5	6.0	pF
COU	Output Capacitance	VOUT = 0V	4.0	8.0	pF

**NOTE:**

3095 tbl 04

- This parameter is measured at characterization but not tested.

## DC ELECTRICAL CHARACTERISTICS OVER OPERATING RANGE

Following Conditions Apply Unless Otherwise Specified:

Commercial:  $T_A = -40^{\circ}\text{C}$  to  $+85^{\circ}\text{C}$ ,  $V_{CC} = 2.7\text{V}$  to  $3.6\text{V}$ ; Military:  $T_A = -55^{\circ}\text{C}$  to  $+125^{\circ}\text{C}$ ,  $V_{CC} = 2.7\text{V}$  to  $3.6\text{V}$

Symbol	Parameter	Test Conditions <sup>(1)</sup>	Min.	Typ. <sup>(2)</sup>	Max.	Unit	
$V_{IH}$	Input HIGH Level (Input pins)	Guaranteed Logic HIGH Level	2.0	—	5.5	V	
	Input HIGH Level (I/O pins)		2.0	—	$V_{CC}+0.5$		
$V_{IL}$	Input LOW Level (Input and I/O pins)	Guaranteed Logic LOW Level	-0.5	—	0.8	V	
$I_{IH}$	Input HIGH Current (Input pins) <sup>(6)</sup>	$V_{CC} = \text{Max.}$	$V_I = 5.5\text{V}$	—	—	$\pm 1$	$\mu\text{A}$
	Input HIGH Current (I/O pins) <sup>(6)</sup>		$V_I = V_{CC}$	—	—	$\pm 1$	
$I_{IL}$	Input LOW Current (Input pins) <sup>(6)</sup>		$V_I = \text{GND}$	—	—	$\pm 1$	
	Input LOW Current (I/O pins) <sup>(6)</sup>		$V_I = \text{GND}$	—	—	$\pm 1$	
$I_{OZH}$	High Impedance Output Current (3-State Output pins) <sup>(6)</sup>	$V_{CC} = \text{Max.}$	$V_O = V_{CC}$	—	—	$\pm 1$	$\mu\text{A}$
$I_{OZL}$			$V_O = \text{GND}$	—	—	$\pm 1$	
$V_{IK}$	Clamp Diode Voltage	$V_{CC} = \text{Min.}, I_{IN} = -18\text{mA}$	—	-0.7	-1.2	V	
$I_{ODH}$	Output HIGH Current	$V_{CC} = 3.3\text{V}, V_{IN} = V_{IH}$ or $V_{IL}, V_O = 1.5\text{V}^{(3)}$	-36	-60	-110	mA	
$I_{ODL}$	Output LOW Current	$V_{CC} = 3.3\text{V}, V_{IN} = V_{IH}$ or $V_{IL}, V_O = 1.5\text{V}^{(3)}$	50	90	200	mA	
$V_{OH}$	Output HIGH Voltage	$V_{CC} = \text{Min.}$ $V_{IN} = V_{IH}$ or $V_{IL}$	$I_{OH} = -0.1\text{mA}$	$V_{CC}-0.2$	—	—	V
			$I_{OH} = -3\text{mA}$	2.4	3.0	—	
		$V_{CC} = 3.0\text{V}$ $V_{IN} = V_{IH}$ or $V_{IL}$	$I_{OH} = -6\text{mA MIL.}$ $I_{OH} = -8\text{mA COM'L.}$	2.4 <sup>(5)</sup>	3.0	—	
$V_{OL}$	Output LOW Voltage	$V_{CC} = \text{Min.}$ $V_{IN} = V_{IH}$ or $V_{IL}$	$I_{OL} = 0.1\text{mA}$	—	—	0.2	V
			$I_{OL} = 16\text{mA}$	—	0.2	0.4	
			$I_{OL} = 24\text{mA}$	—	0.3	0.55	
		$V_{CC} = 3.0\text{V}$ $V_{IN} = V_{IH}$ or $V_{IL}$	$I_{OL} = 24\text{mA}$	—	0.3	0.50	
$I_{OS}$	Short Circuit Current <sup>(4)</sup>	$V_{CC} = \text{Max.}, V_O = \text{GND}^{(3)}$	-60	-135	-240	mA	
$V_H$	Input Hysteresis	—	—	150	—	mV	
$I_{CCL}$ $I_{CCH}$ $I_{CCZ}$	Quiescent Power Supply Current	$V_{CC} = \text{Max.},$ $V_{IN} = \text{GND}$ or $V_{CC}$	COM'L.	—	0.1	10	$\mu\text{A}$
			MIL.	—	0.1	100	

3095 Ink 05

### NOTES:

- For conditions shown as Max. or Min., use appropriate value specified under Electrical Characteristics for the applicable device type.
- Typical values are at  $V_{CC} = 3.3\text{V}, +25^{\circ}\text{C}$  ambient.
- Not more than one output should be tested at one time. Duration of the test should not exceed one second.
- This parameter is guaranteed but not tested.
- $V_{OH} = V_{CC} - 0.6\text{V}$  at rated current.
- The test limits for this parameter is  $\pm 5\mu\text{A}$  at  $T_A = -55^{\circ}\text{C}$ .

## POWER SUPPLY CHARACTERISTICS

Symbol	Parameter	Test Conditions <sup>(1)</sup>		Min.	Typ. <sup>(2)</sup>	Max.	Unit	
$\Delta I_{CC}$	Quiescent Power Supply Current	$V_{CC} = \text{Max.}$	$V_{IN} = V_{CC} - 0.6V^{(3)}$				mA	
$I_{CCD}$	Dynamic Power Supply Current <sup>(4)</sup>	$V_{CC} = \text{Max.}$ Outputs Open $\overline{OE} = \text{GND}$ 50% Duty Cycle One Input Toggling	$V_{IN} = V_{CC}$ $V_{IN} = \text{GND}$				$\mu\text{A}/\text{MHz}$	
$I_C$	Total Power Supply Current <sup>(6)</sup>	$V_{CC} = \text{Max.}$ Outputs Open $f_{CP} = 10\text{MHz}$ 50% Duty Cycle $\overline{OE} = \text{GND}$ $f_i = 5\text{MHz}$ 50% Duty Cycle One Bit Toggling	$V_{IN} = V_{CC}$ $V_{IN} = \text{GND}$				mA	
			$V_{IN} = V_{CC} - 0.6V$ $V_{IN} = \text{GND}$					
		$V_{CC} = \text{Max.}$ Outputs Open $f_{CP} = 10\text{MHz}$ 50% Duty Cycle $\overline{OE} = \text{GND}$ $f_i = 2.5\text{MHz}$ 50% Duty Cycle Eight Bits Toggling	$V_{IN} = V_{CC}$ $V_{IN} = \text{GND}$					
			$V_{IN} = V_{CC} - 0.6V$ $V_{IN} = \text{GND}$					

### NOTES:

3095 tbl 06

- For conditions shown as max. or min., use appropriate value specified under Electrical Characteristics for the applicable device type.
- Typical values are at  $V_{CC} = 3.3V$ ,  $+25^\circ\text{C}$  ambient.
- Per TTL driven input; all other inputs at  $V_{CC}$  or GND.
- This parameter is not directly testable, but is derived for use in Total Power Supply Calculations.
- Values for these conditions are examples of the  $I_{CC}$  formula. These limits are guaranteed but not tested.
- $I_C = I_{QUIESCENT} + I_{INPUTS} + I_{DYNAMIC}$   
 $I_C = I_{CC} + \Delta I_{CC} D_H N_T + I_{CCD} (f_{CP} N_{CP} / 2 + f_i N_i)$   
 $I_{CC} = \text{Quiescent Current (} I_{CCL}, I_{CCH} \text{ and } I_{CCZ} \text{)}$   
 $\Delta I_{CC} = \text{Power Supply Current for a TTL High Input}$   
 $D_H = \text{Duty Cycle for TTL Inputs High}$   
 $N_T = \text{Number of TTL Inputs at } D_H$   
 $I_{CCD} = \text{Dynamic Current Caused by an Input Transition Pair (HLH or LHL)}$   
 $f_{CP} = \text{Clock Frequency for Register Devices (Zero for Non-Register Devices)}$   
 $N_{CP} = \text{Number of Clock Inputs at } f_{CP}$   
 $f_i = \text{Input Frequency}$   
 $N_i = \text{Number of Inputs at } f_i$

### SWITCHING CHARACTERISTICS OVER OPERATING RANGE<sup>(3)</sup>

Symbol	Parameter	Conditions <sup>(1)</sup>	FCT3574				FCT3574A				Unit
			Com'l.		Mil.		Com'l.		Mil.		
			Min. <sup>(2)</sup>	Max.	Min. <sup>(2)</sup>	Max.	Min. <sup>(2)</sup>	Max.	Min. <sup>(2)</sup>	Max.	
tPLH tPHL	Propagation Delay CP to ON <sup>(3)</sup>	CL = 50pF RL = 500Ω	2.0	10.0	2.0	11.0	2.0	6.5	2.0	7.2	ns
tPZH tPZL	Output Enable Time		1.5	12.5	1.5	14.0	1.5	6.5	1.5	7.5	ns
tPHZ tPLZ	Output Disable Time		1.5	8.0	1.5	8.0	1.5	5.5	1.5	6.5	ns
tsu	Set-up Time HIGH or LOW, DN to CP		2.0	—	2.0	—	2.0	—	2.0	—	ns
th	Hold Time HIGH or LOW, DN to CP		1.5	—	1.5	—	1.5	—	1.5	—	ns
tw	CP Pulse Width HIGH or LOW		7.0	—	7.0	—	5.0	—	6.0	—	ns

**NOTES:**

3095 tbl 07

1. See test circuit and waveforms.
2. Minimum limits are guaranteed but not tested on Propagation Delays.
3. Propagation Delays and Enable/Disable times are with Vcc = 3.3V ± 0.3V, Normal Range. For Vcc = 2.7V to 3.6V, Extended Range, all Propagation Delays and Enable/Disable times should be degraded by 20%.

## TEST CIRCUITS AND WAVEFORMS

### TEST CIRCUITS FOR ALL OUTPUTS

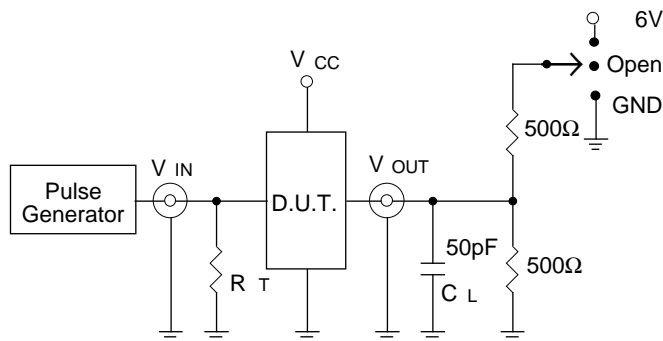

3095 drw 03

### SWITCH POSITION

Test	Switch
Open Drain Disable Low Enable Low	6V
Disable High Enable High	GND
All Other tests	Open

#### DEFINITIONS:

$C_L$  = Load capacitance: includes jig and probe capacitance.  
 $R_T$  = Termination resistance: should be equal to  $Z_{OUT}$  of the Pulse Generator.

3095 Ink 08

### SET-UP, HOLD AND RELEASE TIMES

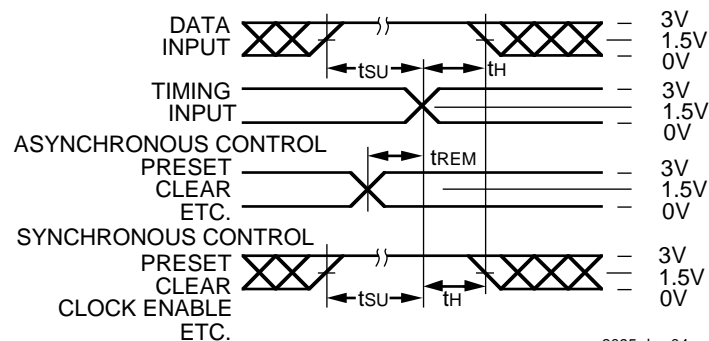

3095 drw 04

### PULSE WIDTH

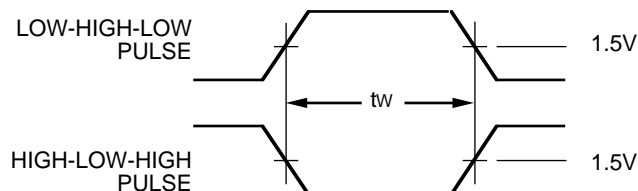

3095 srw 05

### PROPAGATION DELAY

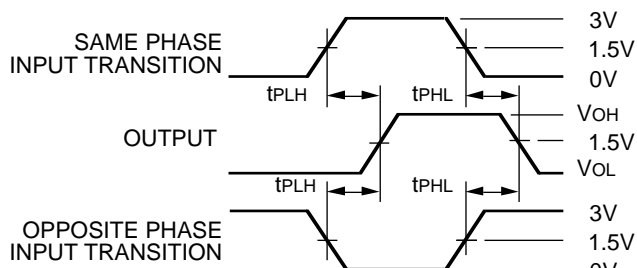

3095 drw 06

### ENABLE AND DISABLE TIMES

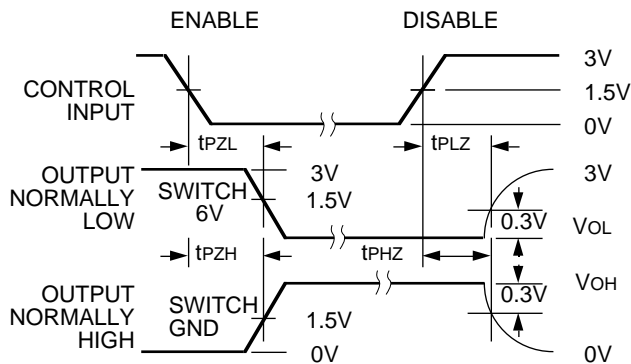

3095 drw 07

#### NOTES:

1. Diagram shown for input Control Enable-LOW and input Control Disable-HIGH.
2. Pulse Generator for All Pulses: Rate  $\leq 1.0\text{MHz}$ ;  $t_f \leq 2.5\text{ns}$ ;  $t_r \leq 2.5\text{ns}$ .
3. If  $V_{CC}$  is below 3V, input voltage swings should be adjusted not to exceed  $V_{CC}$ .

**ORDERING INFORMATION**

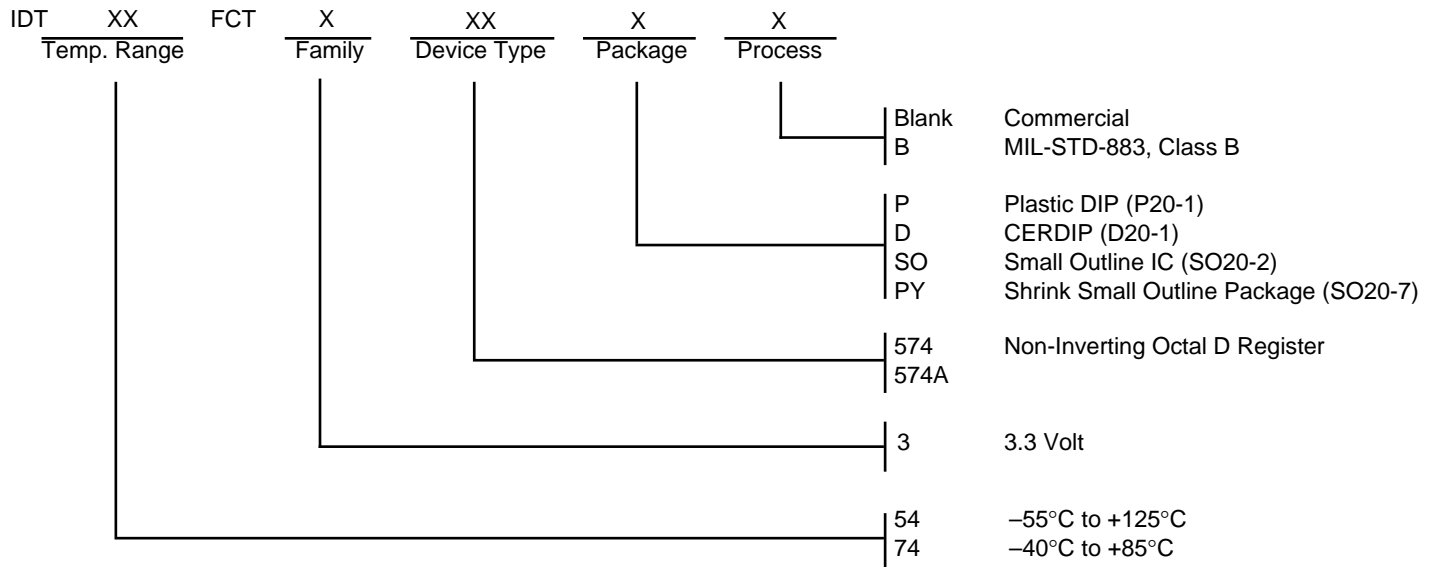

3095 drw 08