



ELECTRONICS, INC.

44 FARRAND STREET
BLOOMFIELD, NJ 07003
(973) 748-5089
<http://www.nteinc.com>

NTE6885 thru NTE6888 Integrated Circuit Hex 3-State Buffer/Inverter

Description:

The NTE6885 thru NTE6888 series of devices combines three features usually found desirable in bus-oriented systems: 1) High impedance logic inputs insure that these devices do not seriously load the bus; 2) Three-state logic configuration allows buffers not being utilized to be effectively removed from the bus; 3) Schottky technology allows high-speed operation.

While the NTE6885 to NTE6888 are all buffers, the devices differ in that the NTE6885 (non-inverting) and the NTE6886 (inverting) provide a two-input Enable which controls all six buffers, while the NTE6887 (non-inverting) and the NTE6888 (inverting) provide two Enable inputs; one controlling four buffers and the other controlling the remaining two buffers.

These units are well-suited for Address buffers on the M6800 or similar microprocessor application.

Features:

- High Speed: 8.0ns (Typ)
- Three-State Logic Configuration
- Single +5V Power Supply Requirement
- Compatible with 74LS Logic or 6800 Microprocessor Systems
- High Impedance PNP Inputs Assure Minimal Loading of the Bus

Absolute Maximum Ratings: ($T_A = +25^\circ\text{C}$ unless otherwise specified for ALL devices)

Power Supply Voltage, V_{CC}	8.0V
Input Voltage, V_I	5.5V
Operating Ambient Temperature Range, T_A	0 to $+75^\circ\text{C}$
Storage Temperature Range, T_{stg}	-55° to $+150^\circ\text{C}$
Operating Junction Temperature, T_J	$+150^\circ\text{C}$

Electrical Characteristics: ($0^\circ\text{C} \leq T_A \leq 75^\circ\text{C}$ and $4.75\text{V} \leq V_{CC} \leq 5.25\text{V}$ unless otherwise specified for ALL devices)

Parameter	Symbol	Test Conditions	Min	Typ	Max	Unit
Input Voltage – High Logic State	V_{IH}	$V_{CC} = 4.75\text{V}, T_A = +25^\circ\text{C}$	2.0	–	–	V
Input Voltage – Low Logic State	V_{IL}	$V_{CC} = 4.75\text{V}, T_A = +25^\circ\text{C}$	–	–	0.8	V
Input Current – High Logic State	I_{IH}	$V_{CC} = 5.25\text{V}, V_{IH} = 2.4\text{V}$	–	–	40	μA
Input Current – Low Logic State	I_{IL}	$V_{CC} = 5.25\text{V}, V_{IL} = 0.5\text{V}, V_{IL(\bar{E})} = 0.5\text{V}$	–	–	-400	μA
Input Current – High Impedance State	$I_{IH(\bar{E})}$	$V_{CC} = 5.25\text{V}, V_{IL(I)} = 0.5\text{V}, V_{IH(\bar{E})} = 2\text{V}$	–	–	-40	μA

Electrical Characteristics (Cont'd): ($0^{\circ}\text{C} \leq T_A \leq 75^{\circ}\text{C}$ and $4.75\text{V} \leq V_{CC} \leq 5.25\text{V}$ unless otherwise specified for ALL devices)

Parameter	Symbol	Test Conditions	Min	Typ	Max	Unit
Output Voltage – High Logic State	V_{OH}	$V_{CC} = 4.75\text{V}, I_{OH} = -5.2\text{mA}$	2.4	–	–	V
Output Voltage – Low Logic State	V_{OL}	$I_{OL} = 48\text{mA}$	–	–	0.5	V
Output Current – High Impedance State	I_{OZ}	$V_{CC} = 5.25\text{V}, V_{OH} = 2.4\text{V}$	–	–	40	μA
		$V_{CC} = 5.25\text{V}, V_{OH} = 0.5\text{V}$	–	–	–40	μA
Output Short-Circuit Current	I_{OS}	$V_{CC} = 5.25\text{V}, V_O = 0, \text{Note 1}$	–40	–80	–115	mA
Power Supply Current NTE6885, NTE6887 NTE6886, NTE6888	I_{CC}	$V_{CC} = 5.25\text{V}$	–	65 59	98 89	mA
Input Clamp Voltage	V_{IC}	$V_{CC} = 4.75\text{V}, I_{IC} = -12\text{mA}$	–	–	–1.5	V
Output V_{CC} Clamp Voltage	V_{OC}	$V_{CC} = 0, I_{OC} = 12\text{mA}$	–	–	1.5	V
Output GND Clamp Voltage	V_{OC}	$V_{CC} = 0, I_{OC} = -12\text{mA}$	–	–	–1.5	V
Input Voltage	V_I	$I_I = 1\text{mA}$	5.5	–	–	V

Note 1. Only one output can be shorted at a time.

Switching Characteristics: ($V_{CC} = 5\text{V}, T_A = +25^{\circ}\text{C}$ unless otherwise specified)

Parameter	Symbol	Test Conditions	NTE6885, NTE6887			NTE6886, NTE6888			Unit
			Min	Typ	Max	Min	Typ	Max	
Propagation Delay Time High to Low State	t_{PHL}	$C_L = 50\text{pF}$	3	–	12	4	–	11	ns
		$C_L = 250\text{pF}$	–	16	–	–	15	–	ns
		$C_L = 375\text{pF}$	–	20	–	–	18	–	ns
		$C_L = 500\text{pF}$	–	23	–	–	22	–	ns
Propagation Delay Time Low to High State	t_{PLH}	$C_L = 50\text{pF}$	3	–	13	3	–	10	ns
		$C_L = 250\text{pF}$	–	25	–	–	22	–	ns
		$C_L = 375\text{pF}$	–	33	–	–	28	–	ns
		$C_L = 500\text{pF}$	–	42	–	–	35	–	ns
Transition Time High to Low State	t_{THL}	$C_L = 250\text{pF}$	–	10	–	–	10	–	ns
		$C_L = 375\text{pF}$	–	11	–	–	13	–	ns
		$C_L = 500\text{pF}$	–	14	–	–	15	–	ns
Transition Time Low to High State	t_{TLH}	$C_L = 250\text{pF}$	–	32	–	–	28	–	ns
		$C_L = 375\text{pF}$	–	42	–	–	38	–	ns
		$C_L = 500\text{pF}$	–	60	–	–	53	–	ns
Propagation Delay Time High State to Third State	$t_{PHZ(\bar{E})}$	$C_L = 5\text{pF}$	–	–	10	–	–	10	ns
Propagation Delay Time Low State to Third State	$t_{PLZ(\bar{E})}$	$C_L = 5\text{pF}$	–	–	12	–	–	16	ns
Propagation Delay Time Third State to High State	$t_{PZH(\bar{E})}$	$C_L = 50\text{pF}$	–	–	25	–	–	22	ns
Propagation Delay Time Third State to Low State	$t_{PZL(\bar{E})}$	$C_L = 50\text{pF}$	–	–	25	–	–	24	ns

Pin Connection Diagrams and Truth Tables

NTE6885

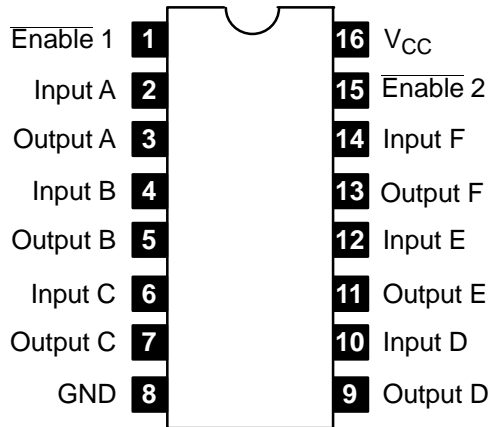

Enable 2	Enable 1	Input	Output
L	L	L	L
L	L	H	H
L	H	X	Z
H	L	X	Z
H	H	X	Z

L = Low Logic State
 H = High Logic State
 Z = Third (High Impedance) State
 X = Don't Care

NTE6886

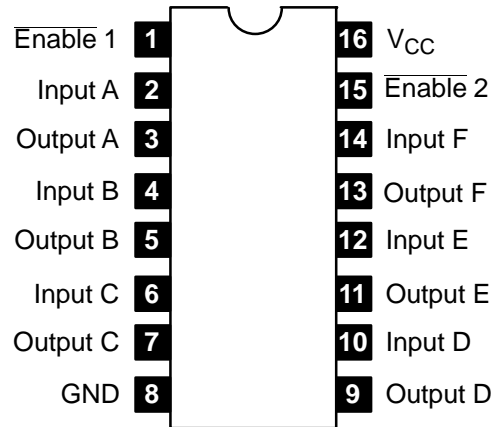

Enable 2	Enable 1	Input	Output
L	L	L	H
L	L	H	L
L	H	X	Z
H	L	X	Z
H	H	X	Z

L = Low Logic State
 H = High Logic State
 Z = Third (High Impedance) State
 X = Don't Care

NTE6887

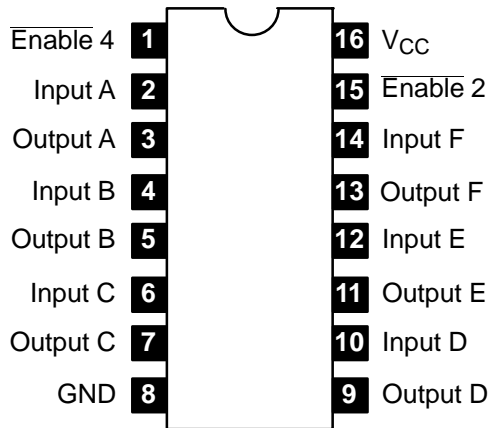

Enable	Input	Output
L	L	L
L	H	H
H	X	Z

L = Low Logic State
 H = High Logic State
 Z = Third (High Impedance) State
 X = Don't Care

NTE6888

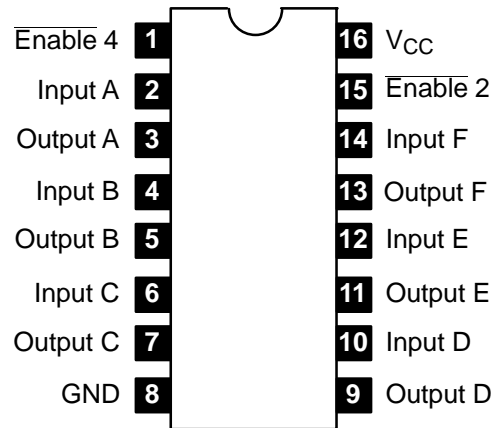

Enable	Input	Output
L	L	H
L	H	L
H	X	Z

L = Low Logic State
 H = High Logic State
 Z = Third (High Impedance) State
 X = Don't Care

