

PWM Control 5A Step-Down Converter

■ Features

- Input voltage: 3.6V to 23V.
- Output voltage: 0.8V to V_{CC} .
- Duty ratio: 0% to 100% PWM control
- Oscillation frequency: 300KHz typ.
- Soft-start, Current limit, Enable function
- Thermal Shutdown function
- Built-in internal SW P-channel MOS
- SOP-16L **Pb-Free** Package.

■ Applications

- Microprocessor core supply
- Networking power supply
- LCD MNT, TV power supply
- Telecom power supply

■ General Description

AP1511 consists of step-down switching regulator with PWM control. These devices include a reference voltage source, oscillation circuit, error amplifier, internal PMOS and etc.

AP1511 provides low-ripple power, high efficiency, and excellent transient characteristics. The PWM control circuit is able to vary the duty ratio linearly from 0 up to 100%. This converter also contains an error amplifier circuit as well as a soft-start circuit that prevents overshoot at startup. An enable function, an over current protect function and a short circuit protect function are built inside, and when OCP or SCP happens, the operation frequency will be reduced from 300KHz to 30KHz. Also, an internal compensation block is built in to minimum external component count.

With the addition of an internal P-channel Power MOS, a coil, capacitors, and a diode connected externally, these ICs can function as step-down switching regulators. They serve as ideal power supply units for portable devices when coupled with the SOP-16L mini-package, providing such outstanding features as low current consumption. Since this converter can accommodate an input voltage up to 23V, it is also suitable for the operation via an AC adapter.

■ Pin Assignments

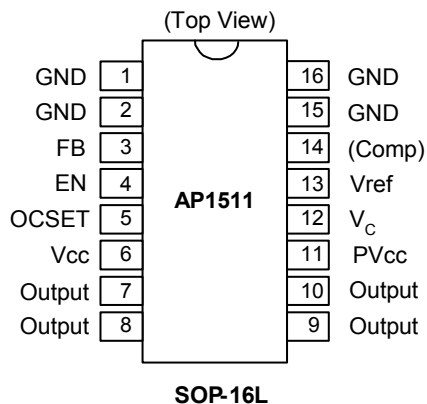

■ Pin Descriptions

Pin Name	Pin No.	Description
GND	1	GND pin
GND	2	GND pin
FB	3	Feedback pin
EN	4	H: Normal operation L: Step-down operation stopped
OCSET	5	Add an external resistor to set max output current.
Vcc	6	Signal Vcc
Output	7	Switch output pin
Output	8	Switch output pin
Output	9	Switch output pin
Output	10	Switch output pin
PVcc	11	Power Vcc
V_C	12	Voltage clamp pin
Vref	13	Reference voltage
(Comp)	14	Option for comp
GND	15	GND pin
GND	16	GND pin

PWM Control 5A Step-Down Converter

■ Ordering Information

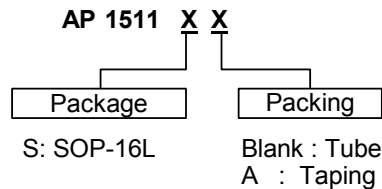

■ Block Diagram

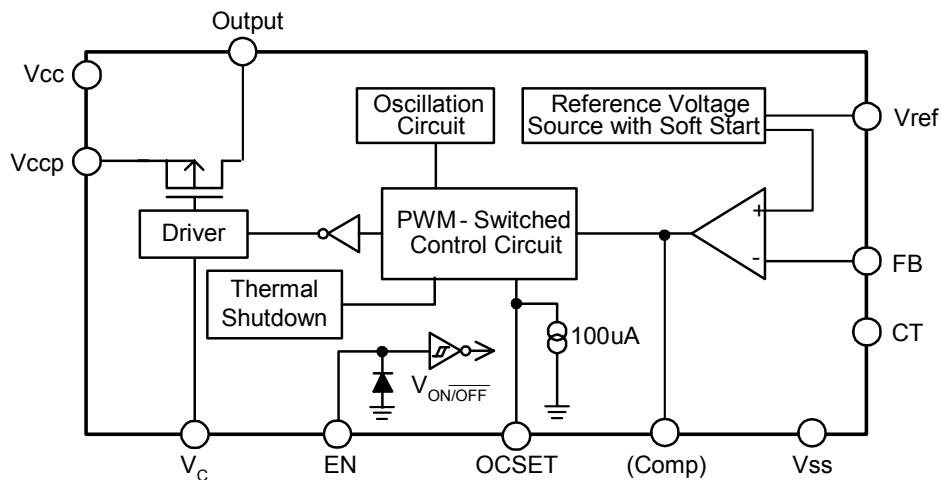

■ Absolute Maximum Ratings

Symbol	Parameter	Rating	Unit
V_{CC}^{*1}	V_{CC} Pin Voltage	$V_{SS} - 0.3$ to $V_{SS} + 25$	V
V_{FB}	V_{OUT} Pin Voltage	$V_{SS} - 0.3$ to V_{CC}	V
$V_{ON/OFF}^{*1}$	ON/OFF Pin Voltage	$V_{SS} - 0.3$ to $V_{CC} + 0.3$	V
V_{OUTPUT}	Switch Pin Voltage	$V_{SS} - 0.3$ to $V_{IN} + 0.3$	V
P_D	Power Dissipation	Internally limited	mW
T_{OPR}	Operating Temperature Range	-20 to +125	°C
T_{STG}	Storage Temperature Range	-40 to +150	°C

Caution: The absolute maximum ratings are rated values exceeding which the product could suffer physical damage. These values must therefore not be exceeded under any conditions.

PWM Control 5A Step-Down Converter

■ Electrical Characteristics ($V_{IN} = 12V$, $T_a = 25^\circ C$, unless otherwise specified)

Symbol	Parameter	Conditions	Min.	Typ.	Max.	Unit
V_{IN}	Input Voltage	--	3.6	-	23	V
V_{FB}	Feedback Voltage	--	0.784	0.8	0.816	V
I_{FB}	Feedback Bias Current	$I_{OUT} = 0.1A$	-	0.1	0.5	μA
ISW	Switch Current	--	5.5	-	-	A
I_{SSS}	Current Consumption During Power Off	$V_{ON/OFF} = 0V$	-	10	-	μA
$\frac{\Delta V_{OUT}}{V_{OUT}}$	Line Regulation	$V_{IN} = 3.6V \sim 23V$	-	1	2	%
$\frac{\Delta V_{OUT}}{V_{OUT}}$	Load Regulation	$I_{OUT} = 0$ to 5A	-	0.5	1	%
f_{OSC}	Oscillation Frequency	Measure waveform at SW pin	240	300	360	KHz
f_{OSC1}	Frequency of Current Limit or Short Circuit Protect	Measure waveform at SW pin	10	30	60	KHz
V_{SH}	Power-Off Pin Input Voltage	Evaluate oscillation at SW pin	2.0	-	-	V
V_{SL}		Evaluate oscillation stop at SW pin	-	-	0.8	
I_{SH}	Power-Off Pin Input Leakage Current	--	-	20	-	μA
I_{SL}		--	-	-10	-	μA
I_{OCSET}	OCSET Pin Bias Current	--	75	90	105	μA
T_{SS}	Soft-Start Time	--	0.3	2	5	ms
R_{DSON}	Internal MOSFET Rdson	$V_{IN} = 5V, V_{FB} = 0V$	-	70	100	m Ω
		$V_{IN} = 12V, V_{FB} = 0V$	-	50	70	
EFFI	Efficiency	$V_{IN} = 12V, V_{OUT} = 5V$ $I_{OUT} = 5A$	-	90	-	%

■ Typical Application Circuit

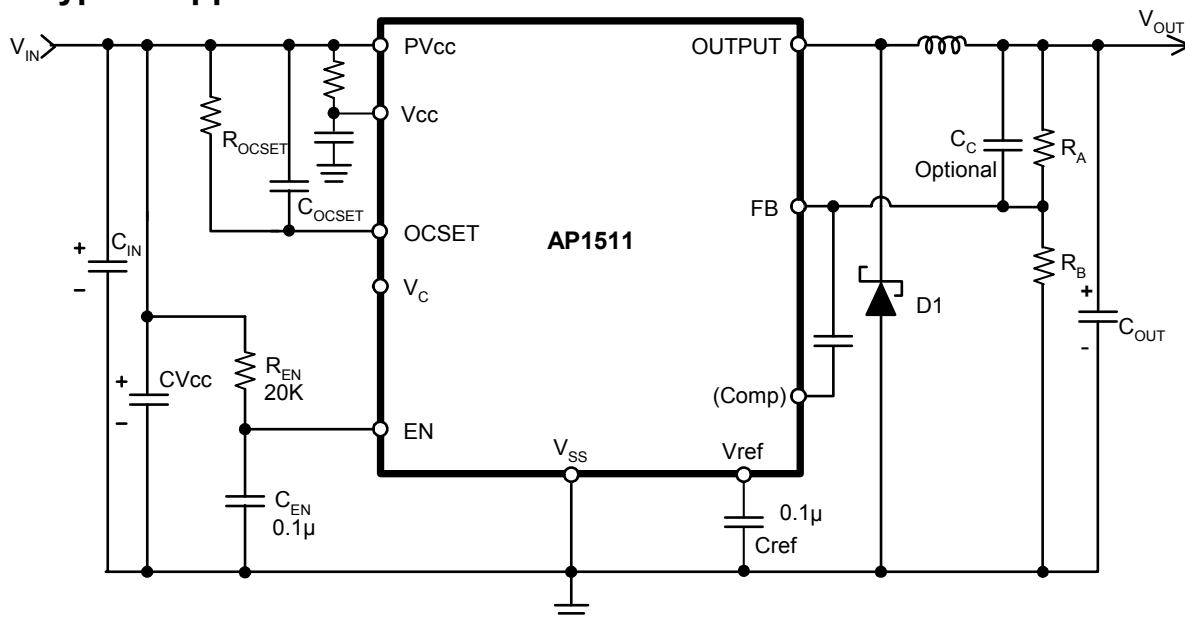

**Note: $V_{OUT} = V_{REF} \times (1 + R_A/R_B)$
 $R_B = 1K \sim 10K$ ohm**

PWM Control 5A Step-Down Converter

■ Test Circuit

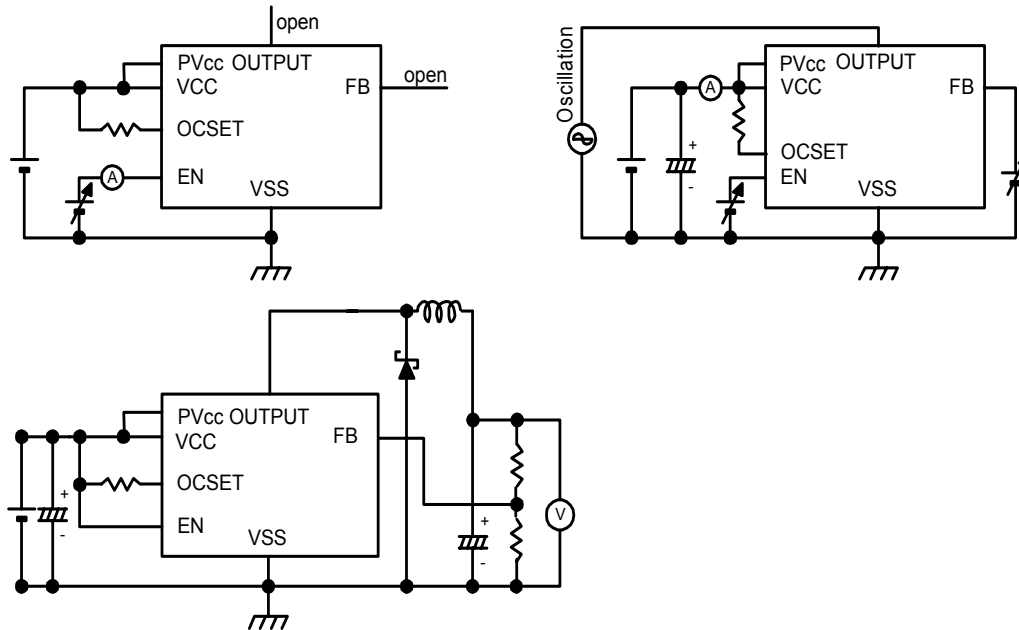

■ Function Description

PWM Control

The AP1511 consists of DC/DC converters that employ a pulse-width modulation (PWM) system. In converters of the AP1511, the pulse width varies in a range from 0 to 100%, according to the load current. The ripple voltage produced by the

switching can easily be removed through a filter because the switching frequency remains constant. Therefore, these converters provide a low-ripple power over broad ranges of input voltage and load current.

■ Marking Information

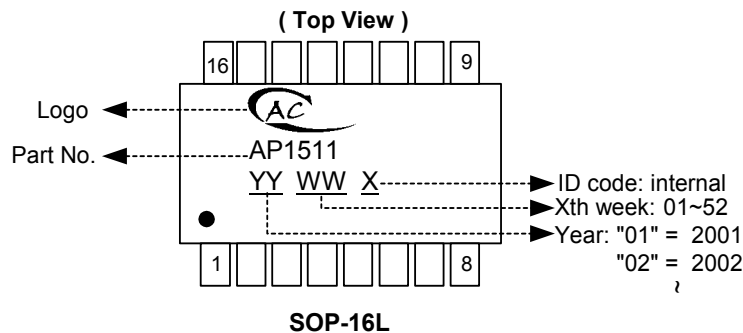

■ Package Information

Package Type: SOP-16L

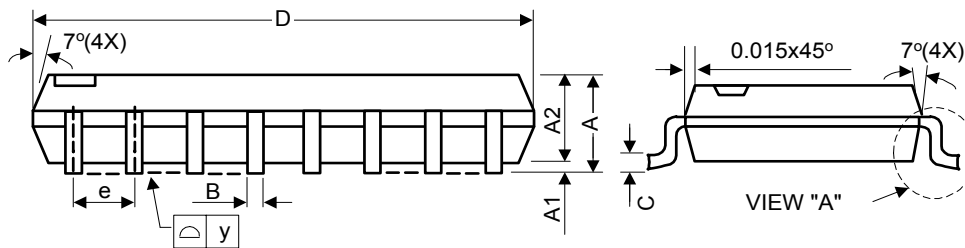
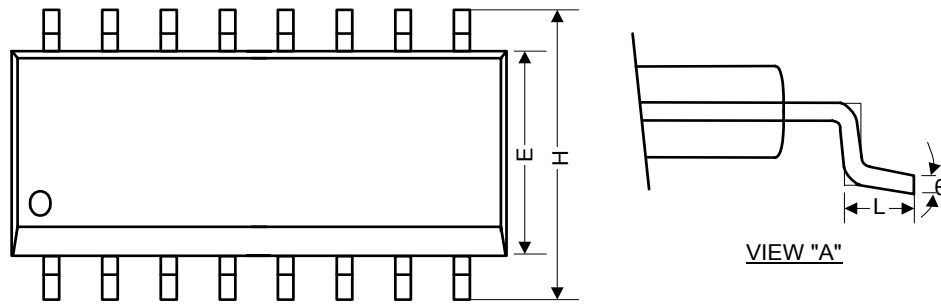

Symbol	Dimensions In Millimeters			Dimensions In Inches		
	Min.	Nom.	Max.	Min.	Nom.	Max.
A	1.40	1.60	1.75	0.055	0.063	0.069
A1	0.10	-	0.25	0.040	-	0.010
A2	1.30	1.45	1.50	0.051	0.057	0.059
B	0.33	0.41	0.51	0.013	0.016	0.020
C	0.19	0.20	0.25	0.0075	0.008	0.0098
D	9.80	9.90	10.00	0.386	0.390	0.394
E	3.80	3.90	4.00	0.150	0.154	0.157
e	-	1.27	-	-	0.050	-
H	5.80	6.00	6.20	0.228	0.236	0.244
L	0.38	0.71	1.27	0.015	0.028	0.050
θ	0	-	8	0	-	8