

- 1 - Anode 1  
 2 - Common Cathode  
 Back of Case - Cathode  
 3 - Anode 2

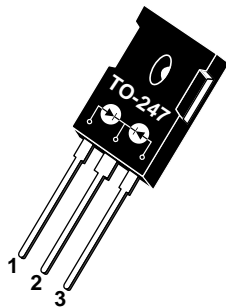

**APT15D100BCT 1000V 2x15A**

## ULTRAFAST SOFT RECOVERY RECTIFIER DIODES

PRODUCT APPLICATIONS	PRODUCT FEATURES	PRODUCT BENEFITS
<ul style="list-style-type: none"> <li>• Parallel Diode               <ul style="list-style-type: none"> <li>-Switchmode Power Supply</li> <li>-Inverters</li> </ul> </li> <li>• Free Wheeling Diode               <ul style="list-style-type: none"> <li>-Motor Controllers</li> <li>-Converters</li> </ul> </li> <li>• Snubber Diode</li> <li>• Uninterruptible Power Supply (UPS)</li> <li>• Induction Heating</li> <li>• High Speed Rectifiers</li> </ul>	<ul style="list-style-type: none"> <li>• Ultrafast Recovery Times</li> <li>• Soft Recovery Characteristics</li> <li>• Popular TO-247 Package</li> <li>• Low Forward Voltage</li> <li>• High Blocking Voltage</li> <li>• Low Leakage Current</li> </ul>	<ul style="list-style-type: none"> <li>• Low Losses</li> <li>• Low Noise Switching</li> <li>• Cooler Operation</li> <li>• Higher Reliability Systems</li> <li>• Increased System Power Density</li> </ul>

### MAXIMUM RATINGS

All Ratings Are Per Leg:  $T_C = 25^\circ\text{C}$  unless otherwise specified.

Symbol	Characteristic / Test Conditions	APT15D100BCT	UNIT
$V_R$	Maximum D.C. Reverse Voltage	1000	Volts
$V_{RRM}$	Maximum Peak Repetitive Reverse Voltage		
$V_{RWM}$	Maximum Working Peak Reverse Voltage		
$I_F(AV)$	Maximum Average Forward Current ( $T_C = 90^\circ\text{C}$ , Duty Cycle = 0.5)	15	Amps
$I_F(RMS)$	RMS Forward Current	25	
$I_{FSM}$	Non-Repetitive Forward Surge Current ( $T_J = 45^\circ\text{C}$ , 8.3ms)	80	
$T_J, T_{STG}$	Operating and Storage Temperature Range	-55 to 150	$^\circ\text{C}$
$T_L$	Lead Temperature: 0.063" from Case for 10 Sec.	300	

### STATIC ELECTRICAL CHARACTERISTICS

Symbol	Characteristic / Test Conditions	MIN	TYP	MAX	UNIT
$V_F$	Maximum Forward Voltage	$I_F = 15\text{A}$		2.3	Volts
		$I_F = 30\text{A}$		2.4	
		$I_F = 15\text{A}, T_J = 150^\circ\text{C}$		1.9	
$I_{RM}$	Maximum Reverse Leakage Current	$V_R = V_R$ Rated		250	$\mu\text{A}$
		$V_R = V_R$ Rated, $T_J = 125^\circ\text{C}$		500	
$C_T$	Junction Capacitance, $V_R = 200\text{V}$		12		pF
$L_S$	Series Inductance (Lead to Lead 5mm from Base)		10		nH

#### USA

405 S.W. Columbia Street

#### EUROPE

Avenue J.F. Kennedy Bât B4 Parc Cadéra Nord

APT Website - <http://www.advancedpower.com>

Bend, Oregon 97702-1035

F-33700 Merignac - France

Phone: (541) 382-8028

Phone: (33) 5 57 92 15 15

FAX: (541) 388-0364

FAX: (33) 5 56 47 97 61

### DYNAMIC CHARACTERISTICS

APT15D100BCT

Symbol	Characteristic	MIN	TYP	MAX	UNIT
$t_{rr1}$	Reverse Recovery Time, $I_F = 1.0A$ , $di_F/dt = -15A/\mu s$ , $V_R = 30V$ , $T_J = 25^\circ C$		60	75	ns
$t_{rr2}$	Reverse Recovery Time		60		
$t_{rr3}$	$I_F = 15A$ , $di_F/dt = -100A/\mu s$ , $V_R = 540V$		120		
$t_{fr1}$	Forward Recovery Time		180		
$t_{fr2}$	$I_F = 15A$ , $di_F/dt = 100A/\mu s$ , $V_R = 540V$		180		
$I_{RRM1}$	Reverse Recovery Current		3.8	7	Amps
$I_{RRM2}$	$I_F = 15A$ , $di_F/dt = -100A/\mu s$ , $V_R = 540V$		4.5	9	
$Q_{rr1}$	Recovery Charge		114		nC
$Q_{rr2}$	$I_F = 15A$ , $di_F/dt = -100A/\mu s$ , $V_R = 540V$		270		
$V_{fr1}$	Forward Recovery Voltage		5.8		Volts
$V_{fr2}$	$I_F = 15A$ , $di_F/dt = 100A/\mu s$ , $V_R = 540V$		5.8		
$diM/dt$	Rate of Fall of Recovery Current		100		A/ $\mu s$
	$I_F = 15A$ , $di_F/dt = -100A/\mu s$ , $V_R = 540V$ (See Figure 10)		50		

### THERMAL AND MECHANICAL CHARACTERISTICS

Symbol	Characteristic / Test Conditions	MIN	TYP	MAX	UNIT
$R_{\theta JC}$	Junction-to-Case Thermal Resistance			1.7	$^\circ C/W$
$R_{\theta JA}$	Junction-to-Ambient Thermal Resistance			80	
$W_T$	Package Weight		0.07		oz
			1.9		gm
Torque	Maximum Mounting Torque (Screw Type = 6-32 or 3.5mm Machine)			6.4	lb•in
				0.7	N•m

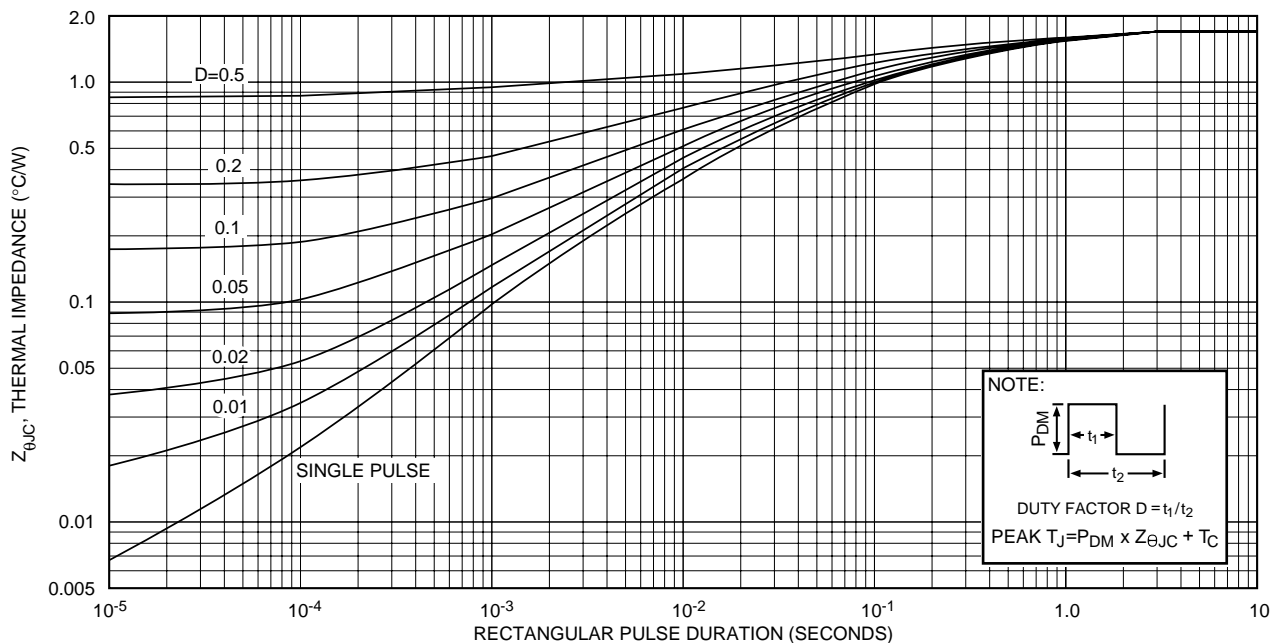
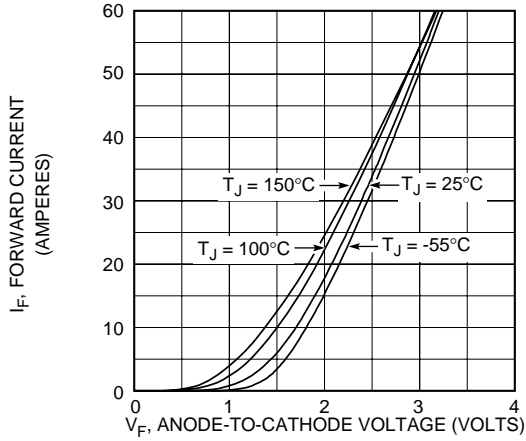
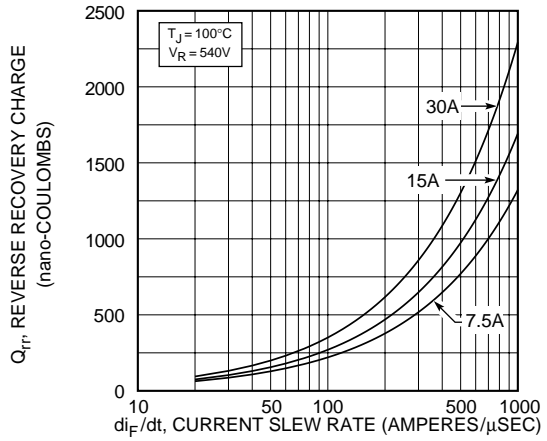

Figure 1, Maximum Effective Transient Thermal Impedance, Junction-To-Case vs Pulse Duration

**APT15D100BCT**



**Figure 2, Forward Voltage Drop vs Forward Current**



**Figure 3, Reverse Recovery Charge vs Current Slew Rate**

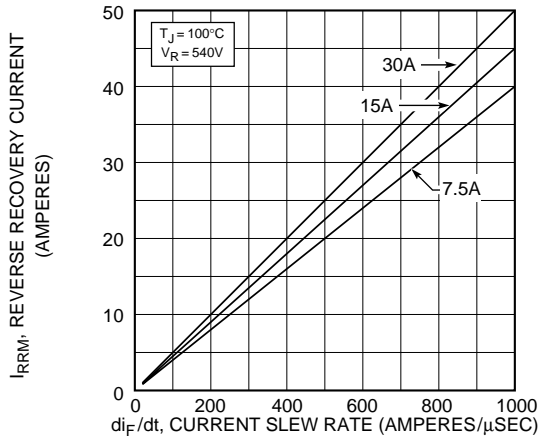

**Figure 4, Reverse Recovery Current vs Current Slew Rate**

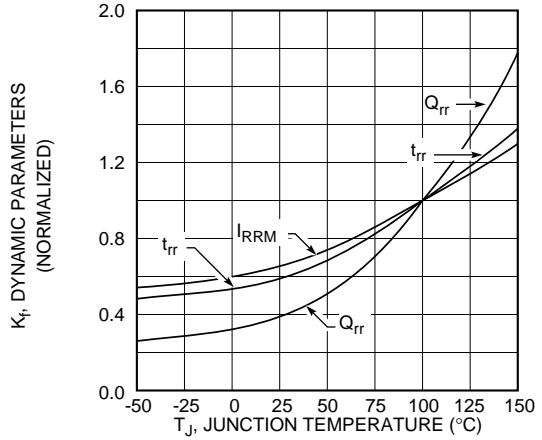

**Figure 5, Dynamic Parameters vs Junction Temperature**

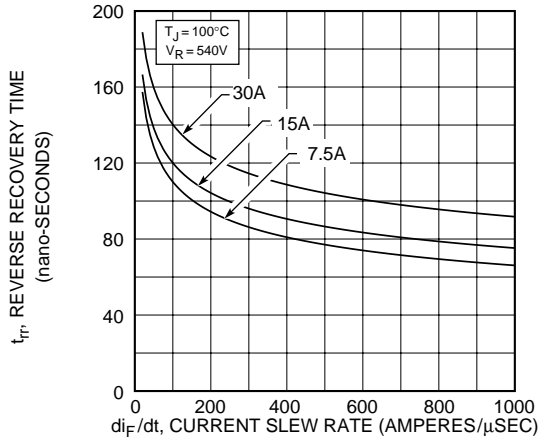

**Figure 6, Reverse Recovery Time vs Current Slew Rate**

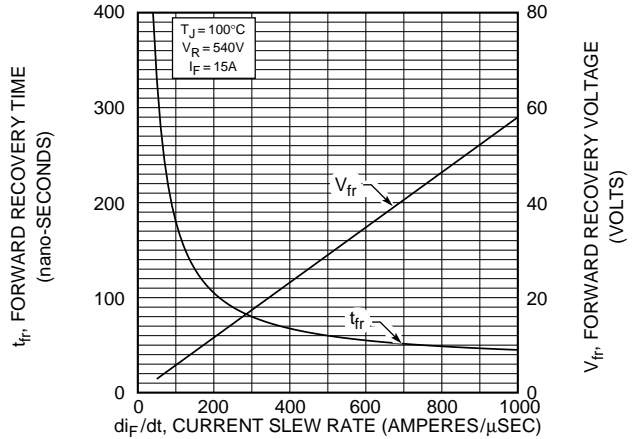

**Figure 7, Forward Recovery Voltage/Time vs Current Slew Rate**

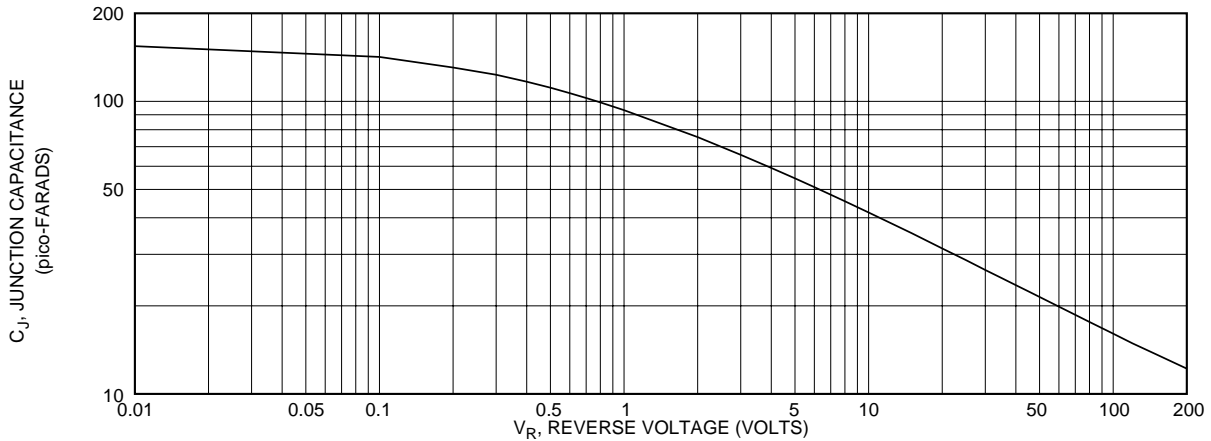

**Figure 8, Junction Capacitance vs Reverse Voltage**

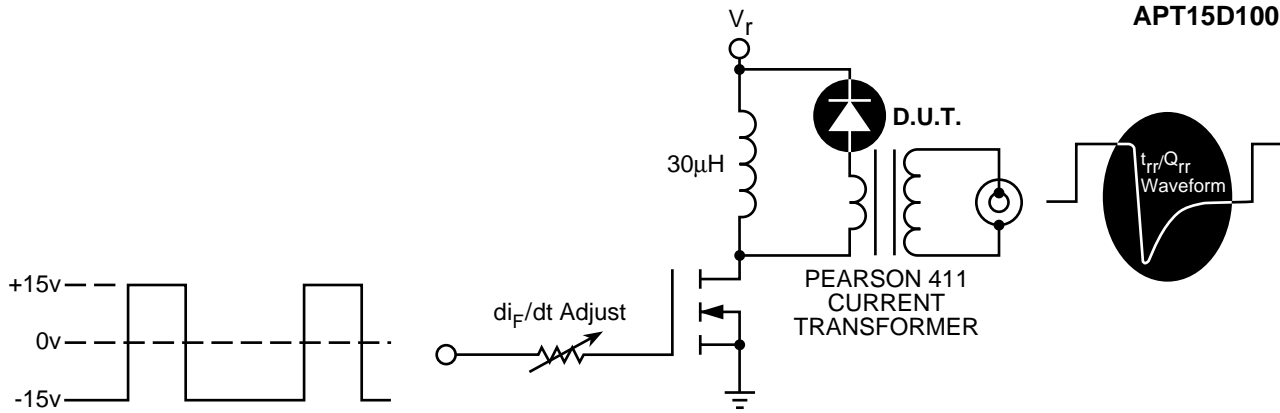

Figure 9, Diode Reverse Recovery Test Circuit and Waveforms

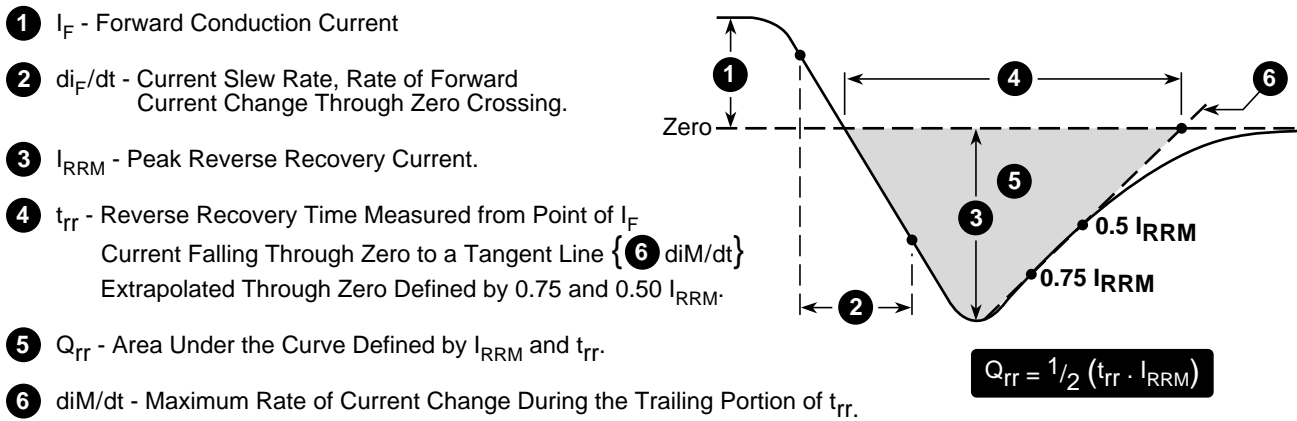
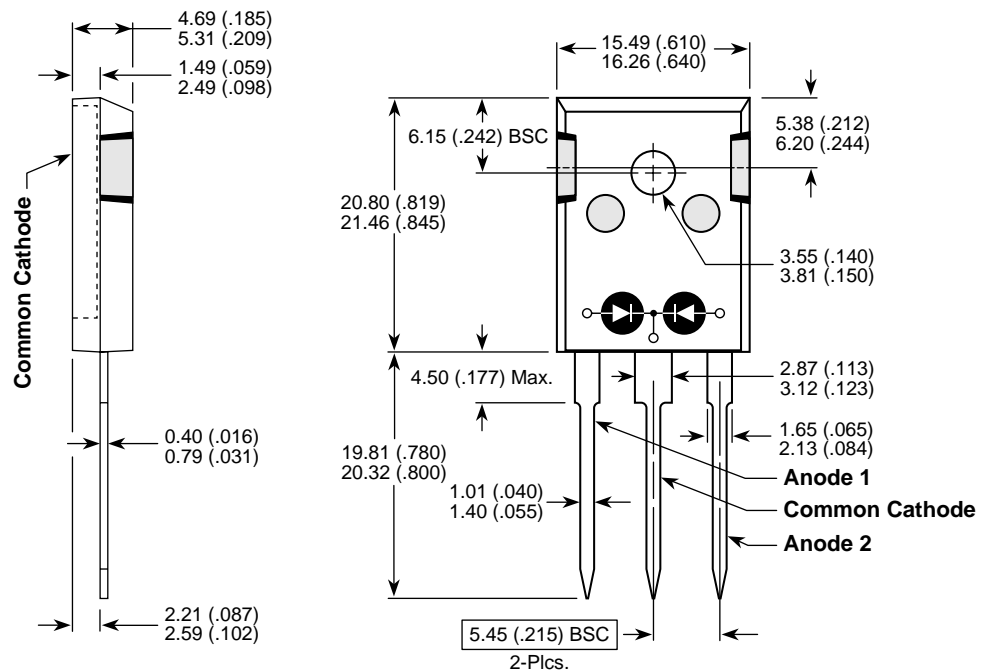

Figure 10, Diode Reverse Recovery Waveform and Definitions

TO-247AD Package Outline



Dimensions in Millimeters and (Inches)