

TDA 4321 XS

Table of Contents

**FM-IF IC with counter output, analog STS, field strength
indicator, noise detector and mute setting**

Table of Contents	Page	1
Functional Description, Application	Page	2
Circuit Description	Page	3
Block Diagramm	Page	4
Pin Assignment	Page	5
Package Outline	Page	6
Absolute Maximum Ratings	Page	7
Operational Range	Page	8
AC / DC Characteristics $T_{amb} = +25^{\circ}\text{C}$	Page	9 ... 10
Test Circuit	Page	11
Application Circuit	Page	12
Diagrams	Page	13 ...16

This specification replaces the previous editions

DOK-Nr.	date	DOK-Nr.	date
V66047-S1665-B100-V1	24.7.98		

The reproduction, transmission or use of this document or its contents is not permitted without express written authority. Offenders will be liable for damages. All rights, including rights created by patent grant or registration of a utility model or design, are reserved.

TDA 4321 XS

Functional Description, Application

The FM-IF-Demodulator TDA 4321 XS has been developed especially for car radio applications. The on-chip multipath identification circuit activates an interference suppression circuit in case of multipath interferences.

The TDA 4321 XS includes an:

- 7stage limiter amplifier
- Coincidence demodulator
- Counter output with request input
- Field strength output
- Analog Multipath identification circuit
- Adjustable muting depth (with full muting $\geq 80\text{dB}$)
- STS function.

This device is ESD protected.

TDA 4321 XS

Circuit Description

The IC includes a 7 stage capacitive coupled-limiter amplifier with coincidence demodulator and AF output. The AF output signal can be continuously attenuated to decrease the noise.

In case of multipath interferences, the TDA 4321 XS includes an identification circuitry with analog output.

There is a field strength output (with min. 76 dB dynamic range, typ. ± 1 dB nonlinearity and typ. ± 3 dB temperature drift), an IF-Counter output and an adjustable muting (with full muting ≥ 80 dB). An STS output with adjustable threshold and stop window is available.

Block Diagram

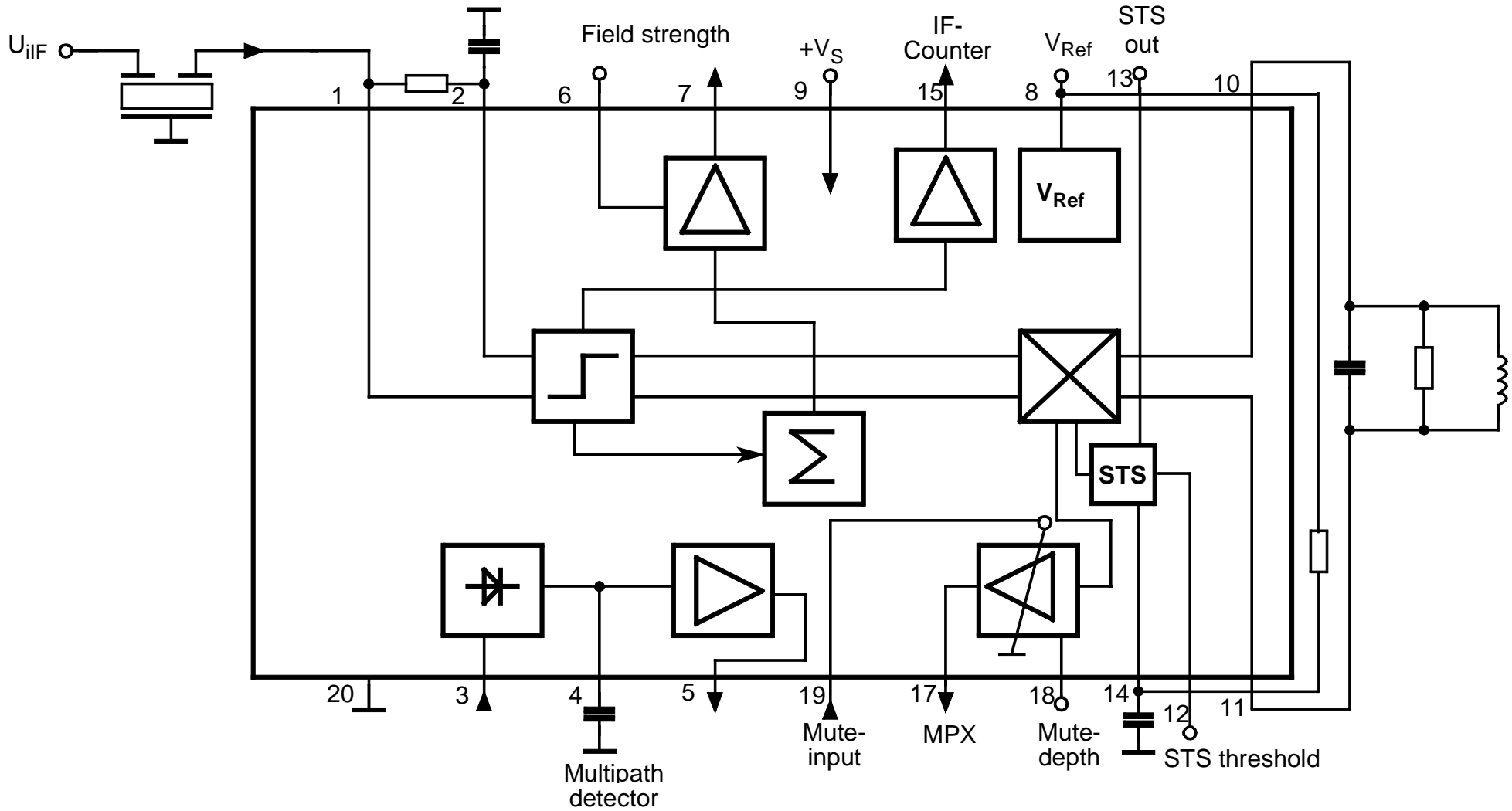

TDA 4321 XS

Pin Assignment

- 1 IF input
- 2 IF input bias
- 3 Multipath identification input
- 4 Rectifier time constant
- 5 Multipath identification output
- 6 Field strength adjust
- 7 Field strength output
- 8 Reference voltage output
- 9 Supply voltage
- 10 Demodulator circuit
- 11 Demodulator circuit
- 12 STS threshold
- 13 STS output
- 14 STS filter time constant and stop window width
- 15 IF-Counter output
- 16 NC
- 17 MPX output
- 18 Mute depth
- 19 Mute input
- 20 Ground

TDA 4321 XS

Package Outline

Plastic-Package
TSSO-P 20-1

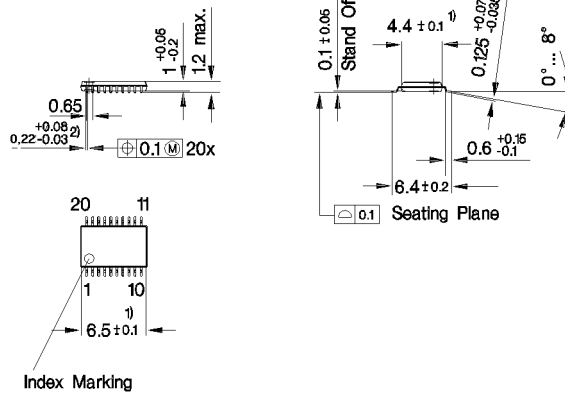

- 1) Does not include plastic or metal protrusion of 0.15 max. per side
 2) Does not include dambar protrusion of 0.08 max. per side

TDA 4321 XS

Absolute Maximum Ratings

The maximal ratings may not be exceeded under any circumstances, not even momentarily and individually, as permanent damage to the IC will result.

#	Max. Ratings for ambient temperature T_{amb} -40 °C to +85 °C	Symbol	Min	Max	Units	Remarks
1	Supply voltage	V_S	0	+13.5	V	
2	Junction temperature	T_j		+150	°C	
3	Storage temperature	T_s		+125	°C	
4	ESD voltage, HBM (1.5 k Ω ,100pF)	V_{ESD}	-4	+4	kV	
5	Thermal Resistance	R_{thsa}		115	K/W	

TDA 4321 XS

Operational Range

Within the operational range the IC operates as described in the circuit description. The AC / DC characteristic limits are not guaranteed.

#	Parameter	Symbol	Min	Max	Units	Remarks
1	Supply voltage	V_S	+7.5	+11	V	
2	Ambient temperature	T_{amb}	-40	+85	°C	

TDA 4321 XS

AC / DC Characteristics

AC / DC characteristics involve the spread of values guaranteed within the specified supply voltage and ambient temperature range. Typical characteristics are the median of the production.

#	Parameter	Symbol	Test Conditions	Test Circuit	Min	Typ	Max	Units					
Measuring condition:													
$V_S = 10\text{ V}; f_{iIF} = 10.7\text{ MHz}; \Delta f = 75\text{ kHz}; f_{mod} = 1\text{ kHz}; V_{iIF} = 10\text{ mV}_{rms}; T_{amb} = +25^\circ\text{C}$													
1	Current consumption	I_9	$V_{19} = 4.8\text{ V}; V_{18} = 4\text{ V}$	1		33	41	mA					
2	Stabilized voltage	V_8	$V_{19} = 4.8\text{ V}; V_{18} = 4\text{ V}$	1	4.5	4.8	5.1	V					
3	Field strength output	V_7	$V_{19} = 4.8\text{ V}; V_{18} = 4\text{ V}$		74	80		dB					
	-dynamic range			D1									
	-nonlinearity			D2						± 1			
	-temperature drift			D3							± 3		
	-Load capacitance										50		
	-Load resistance				1			k Ω					
		V_7	$V_{1rms} = 200\text{ mV}$	1	5	5.4	5.8	V					
		V_7	$V_{1rms} = 1\text{ mV}$	1	2.3	2.7	3.1	V					
		V_7	$V_{1rms} = 0\text{ mV}$	1	0		1.1	V					
4	Input voltage for limiter threshold	V_1	$V_{17} = -3\text{ dB}$	1		20	30	μV_{rms}					
5	AF-output voltage	V_{17}	$V_{19} = 4.8\text{ V}; V_{18} = 4\text{ V}$	1	460	550	640	mV_{rms}					
6	AF-output voltage	V_{17}	$V_{19} = 4.8\text{ V}; V_{18} = 4\text{ V}$ $R_{10-11} = 2\text{ k}; \Delta f = 22.5\text{ kHz}$	Lab		80		mV_{rms}					
7	Total harmonic distorton	THD ₁₇	$V_{19} = 4.8\text{ V}; V_{18} = 4\text{ V}$	1			0.8	%					
8	AM-suppression	a_{AM}	$m = 80\%$	1	60			dB					
			$m = 30\%$	1	70			dB					
9	Signal-to-noise ratio	$a_{S/N}$	$V_{19} = 4.8\text{ V}; V_{18} = 4\text{ V}$	1	76	84		dB					
10	Counter-output voltage	V_{15}	$C_L = 5\text{ pF}; R_{i15} = 1.5\text{ k}$	1	50	80		mV_{rms}					

TDA 4321 XS

AC / DC Characteristics

AC / DC characteristics involve the spread of values guaranteed within the specified supply voltage and ambient temperature range. Typical characteristics are the median of the production.

#	Parameter	Symbol	Test Conditions	Test Circuit	Min	Typ	Max	Units
Measuring condition: $V_S = 10\text{ V}$; $f_{\text{IF}} = 10.7\text{ MHz}$; $\Delta f = 75\text{ kHz}$; $f_{\text{mod}} = 1\text{ kHz}$; $V_{\text{IF}} = 10\text{ mV}_{\text{rms}}$; $T_{\text{amb}} = +25^\circ\text{C}$								
14	Attack current	I_4^*	$V_{3\text{AC}} = 1V_{\text{pp}}$; $V_m = 5.0\text{V}$	1	700	900	1100	μA
15	Recovery current	I_4^*	$V_{3\text{AC}} = 0\text{V}$; $V_m = 3.6\text{V}$	1	-6	-9	-12	μA
16	Start voltage	$V_{5\text{Def}}$	$V_{3\text{AC}} = 0\text{V}$	1	4.4	4.7		V
17	Detector characteristic	V_5	$V_3 = 100\text{mV}_{\text{pp}}$	1	$V_{5\text{Def}-3.5\text{V}}$	$V_{5\text{Def}-3\text{V}}$	$V_{5\text{Def}-2.5\text{V}}$	V
18	Detector characteristic	V_5	$V_3 = 350\text{mV}_{\text{pp}}$	1			500	mV
19	AF mute	a_{AF}	$V_{19} = 4.8\text{V}$; $V_{18} = 4.8\text{V}$	D4		0		dB
			$V_{19} = 0\text{V}$; $V_{18} = 4.8\text{V}$	D4	-2		2	dB
			$V_{19} = 0\text{V}$; $V_{18} = 2.4\text{V}$	D4	32	38	44	dB
			$V_{19} = 4.8\text{V}$; $V_{18} \leq 1.0\text{V}$	D4	80			dB
			$V_{19} = 0\text{V}$; $V_{18} \leq 1.0\text{V}$	D4	80			dB
20	Voltage for mute off	V_{19}		1	0.5			V
21	Voltage for mute on	V_{19}		1	0		0.1	V
22	Search tuning stop window	f_{STS13}	$R_{8-14} = 56\text{k}\Omega$	1			± 25	kHz
23	Search tuning stop offset	f_{STOffs}	$R_{8-14} = 56\text{k}\Omega$; THD = min	1			± 10	kHz
24	Search tuning stop threshold FM	V_{IST1}	$V_{12} = \text{open}$	1	50	100	200	μV_{rms}
			$V_{12} = 2.4\text{V}$	1	0.65	1.3	2.6	mV_{rms}

*) Integrator currents are measured between the output pin (- Pole of the measurement equipment) and a voltage source V_m (+ Pole)

Test Circuit

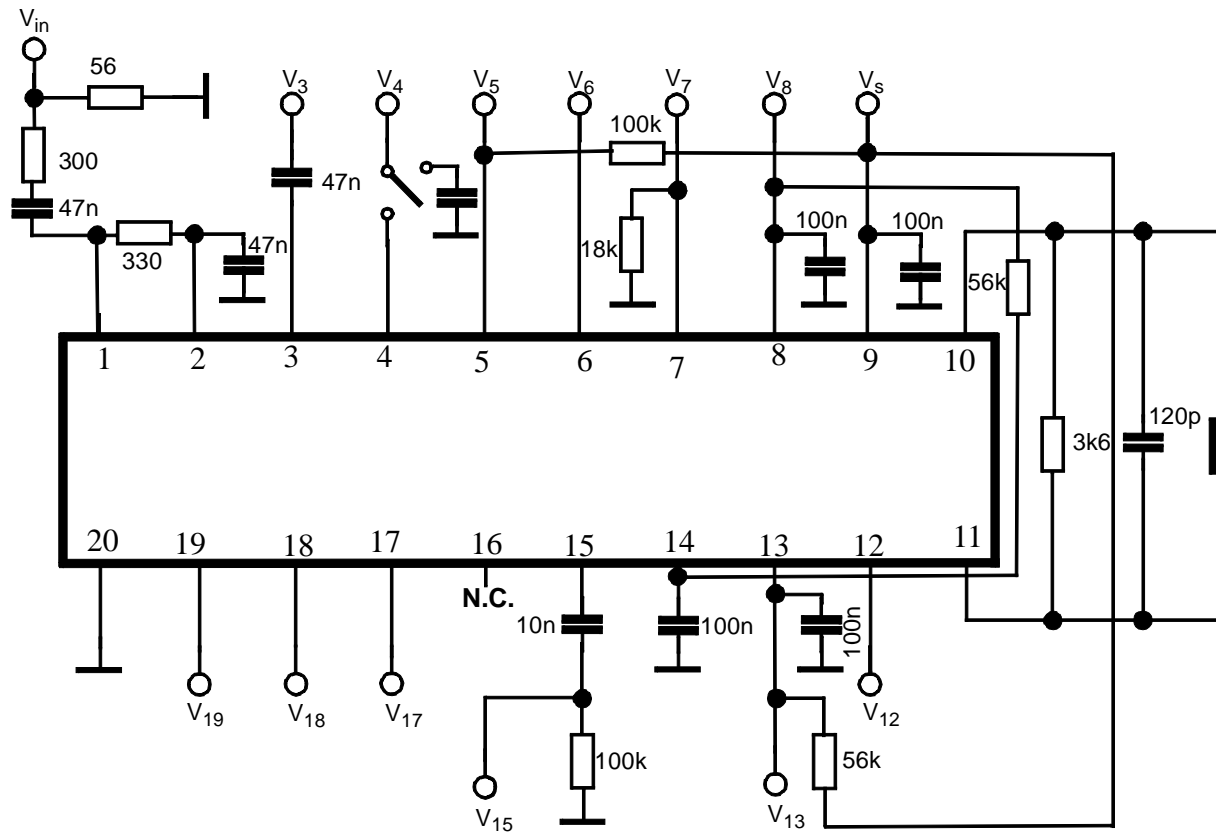

Application Circuit

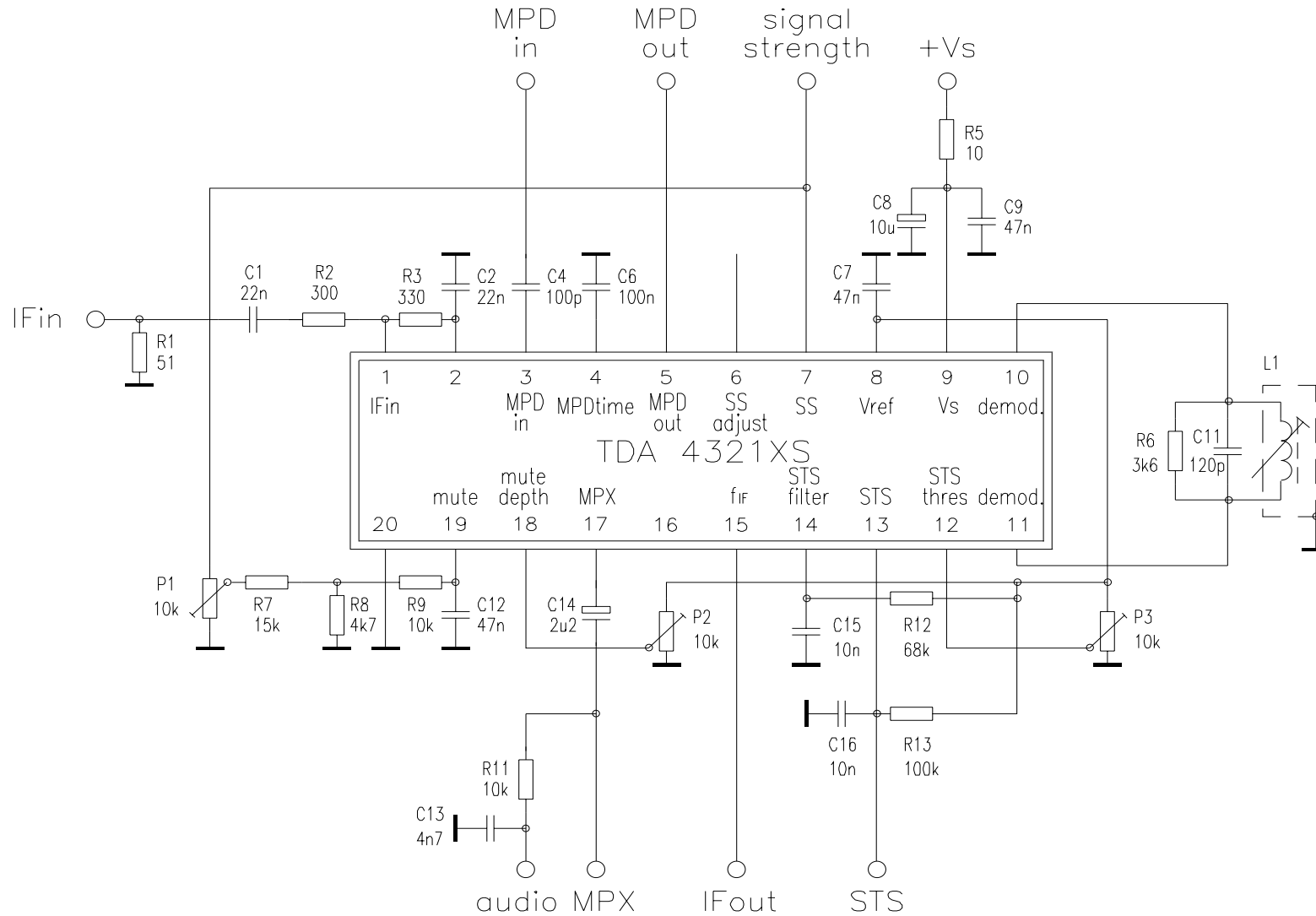

TDA 4321 XS

Diagrams

V_F Characteristic

D1

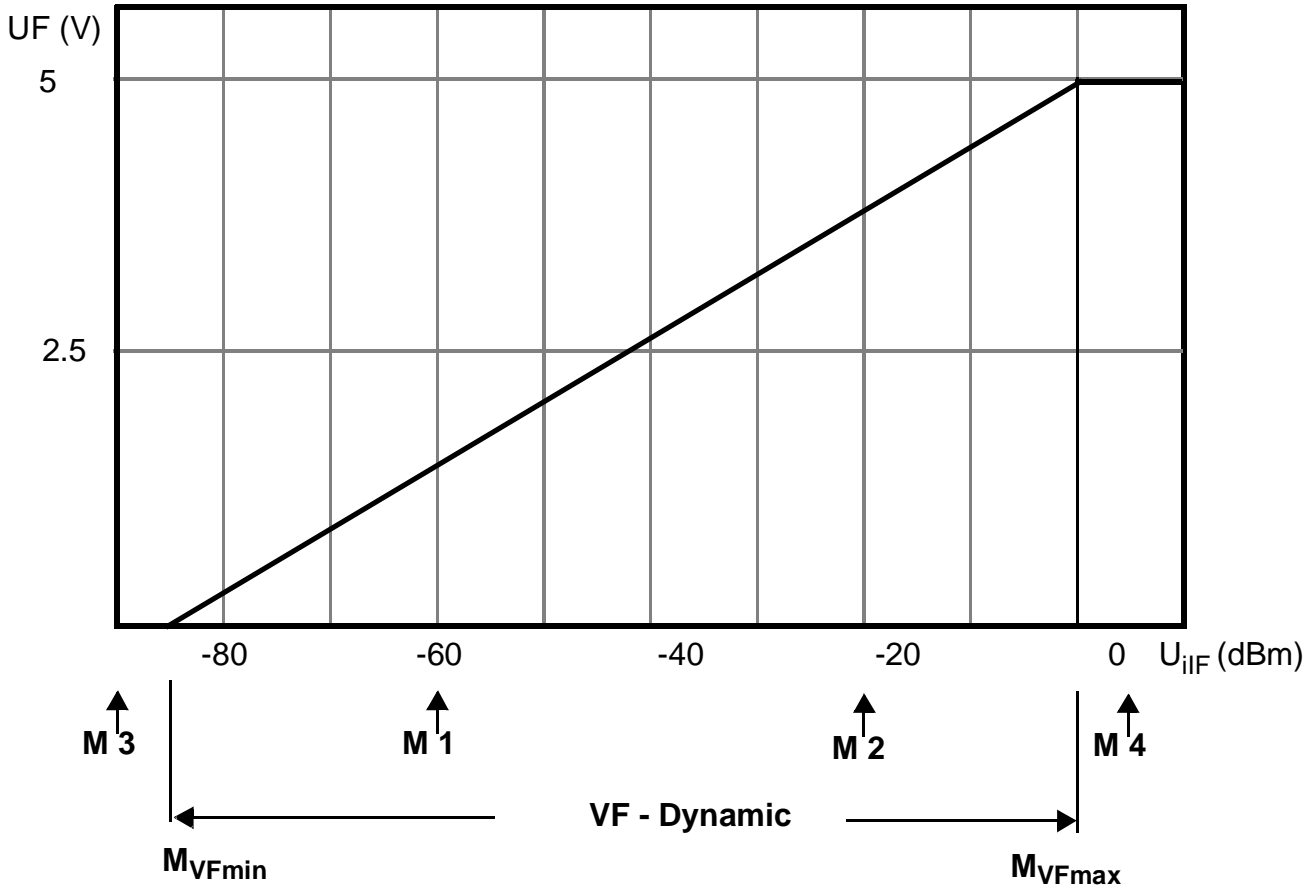

V_F - Dynamic :The dynamic range of V_F voltage is determined by the test points M1 through M4 as follows:

- M1: test point (at $V_{ilF} = -60$ dBm) supplies V_F (M1)
- M2: test point (at $V_{ilF} = -20$ dBm) supplies V_F (M2)
- M3: test point (at $V_{ilF} = -90$ dBm) supplies V_F (M3)
- M4: test point (at $V_{ilF} = +5$ dBm) supplies V_F (M4)

Hence follows :

$$M_{VFmax} := -20 \text{ dBm} + \frac{U_F(M4) - U_F(M2)}{U_F(M2) - U_F(M1)} \times 40 \text{ dB}$$

$$M_{VFmin} := -60 \text{ dBm} - \frac{U_F(M1) - U_F(M3)}{U_F(M2) - U_F(M1)} \times 40 \text{ dB}$$

$$VF - Dynamic = M_{VFmax} - M_{VFmin}$$

TDA 4321 XS

Diagrams

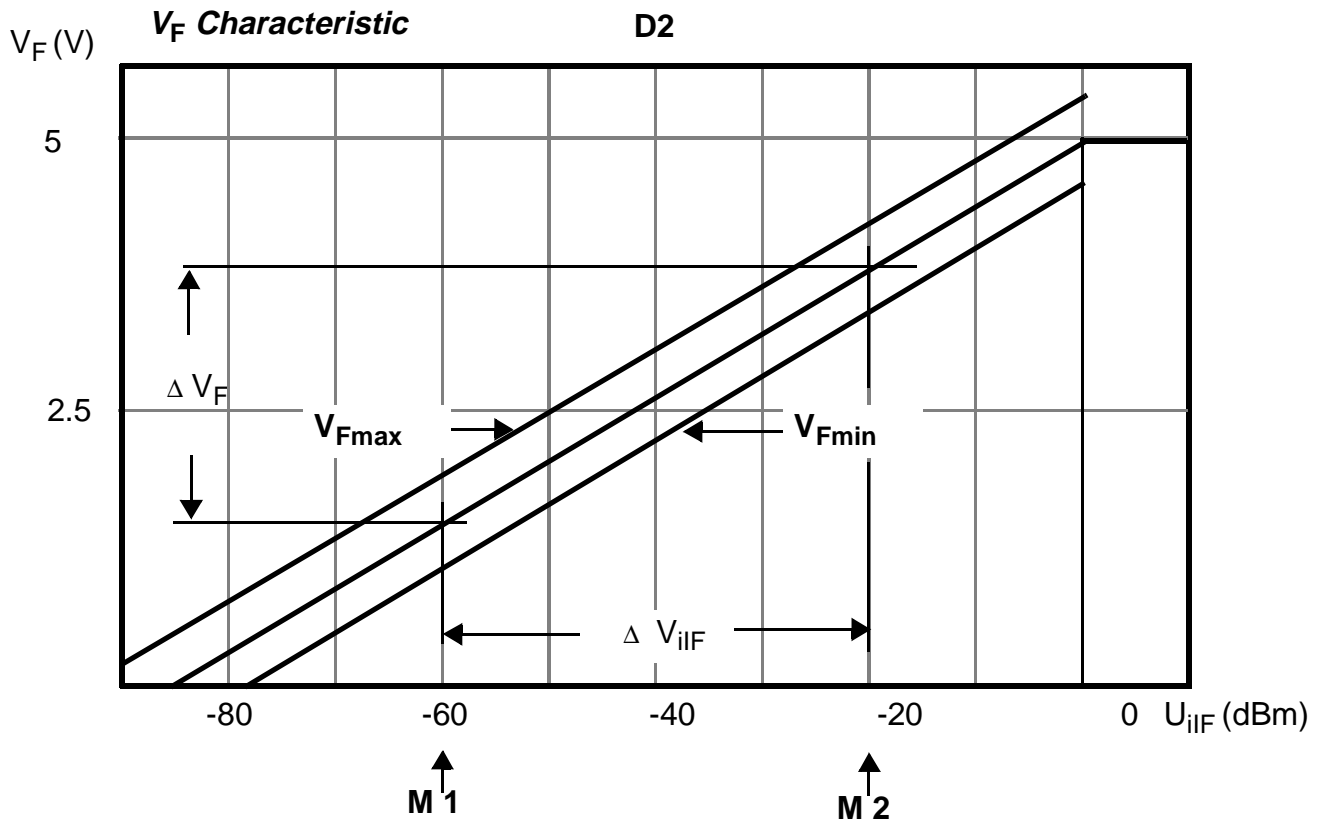

Test points to determine VF linearity

VF - Linearity: is determined at 25 °C

$$\text{Slope } : m = \frac{V_F (M2) - V_F (M1)}{40 \text{ dB}}$$

The tolerance range of the VF - linearity is determined by two parallel lines:

$$V_{Fmax} = V_F (M1) + m (M + 60 \text{ dB} + 1 \text{ dB})$$

$$V_{Fmin} = V_F (M1) + m (M + 60 \text{ dB} - 1 \text{ dB})$$

The \$V_F\$ values within the \$V_F\$ dynamic range (\$M_{VFmin} \le M \le M_{VFmax}\$) must be inside the predetermined tolerance range:

$$V_{Fmin} \le V_F (M) \le V_{Fmax}$$

TDA 4321 XS

Diagrams

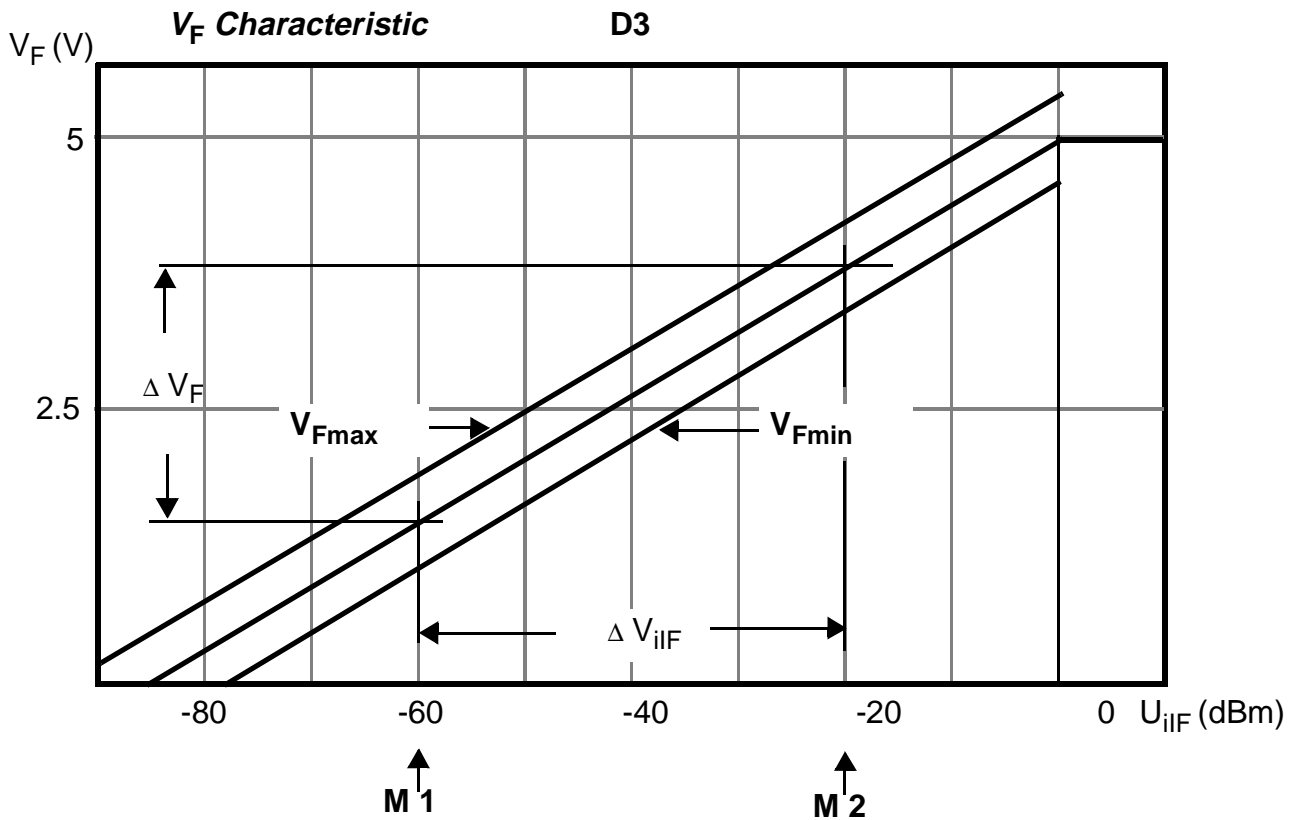

Test points to determine \$V_F\$ temperature drift

\$V_F\$ -Temperatur - Drift : It is determined within -40 bis +85 °C

$$\text{Slope } : m = \frac{U_F (M2) - U_F (M1)}{40 \text{ dB}} \quad (\text{at } 25 \text{ }^\circ\text{C})$$

The tolerance range of the \$V_F\$ temperature drift is determined by two parallel lines:

$$V_{Fmax} = V_F (M1) + m (M + 60 \text{ dB} + 3\text{dB})$$

$$V_{Fmin} = V_F (M1) + m (M + 60 \text{ dB} - 3\text{dB})$$

The \$V_F\$ values for temperatures between -40 to +85 °C within the \$V_F\$ dynamic range (\$M_{VFmin} \le V_F \le M_{VFmax}\$) must be inside the predetermined tolerance field:

$$V_{Fmin} \le V_F (M) \le V_{Fmax}$$

TDA 4321 XS

Diagrams

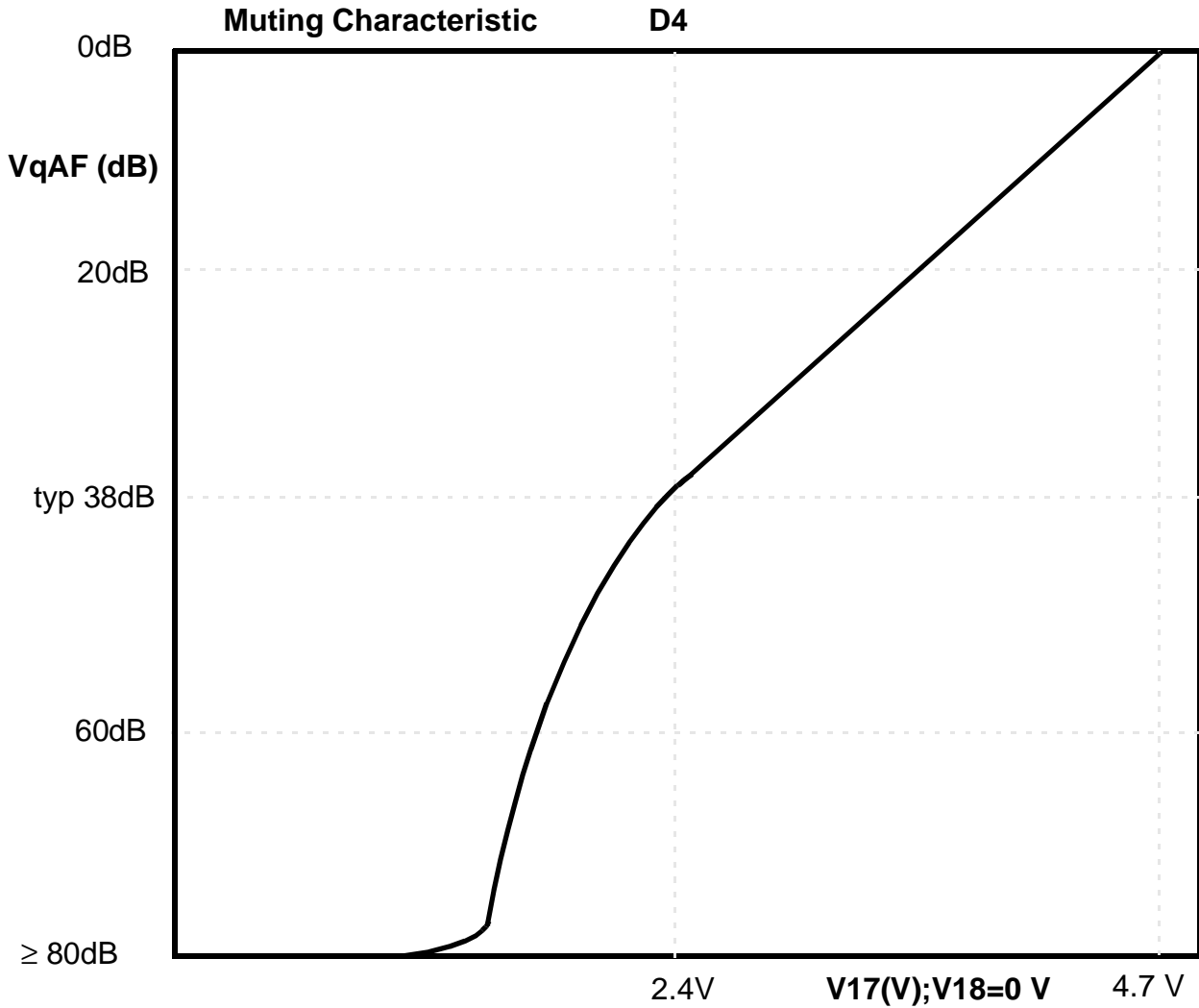

Diagram of Mute Characteristic