



UHF, EPCglobal, Contactless Memory IC 96 bit ePC with Inventory and Kill Function

DATA BRIEF

FEATURES SUMMARY

- Based on the EPCglobal class 1b specification
- UHF Carrier Frequencies
 - 868MHz ISM Band
 - 915MHz ISM Band
- To the XRA00:
 - Asynchronous 50% to 100% ASK modulation using PWM pulse coding (up to 70 kbit/s)
- From the XRA00:
 - Back-scattered answers using Bi-phase Space coding (up to 140 kbit/s)
- 128 bits EEPROM with Lock Function
- 96 bits ePC
- Inventory, Read, Program and Erase functions
- Kill Command
- 30ms Programming Time (typical)
- More than 10000 Write/Erase cycles
- More than 40 Year Data Retention

Figure 1. Delivery Forms

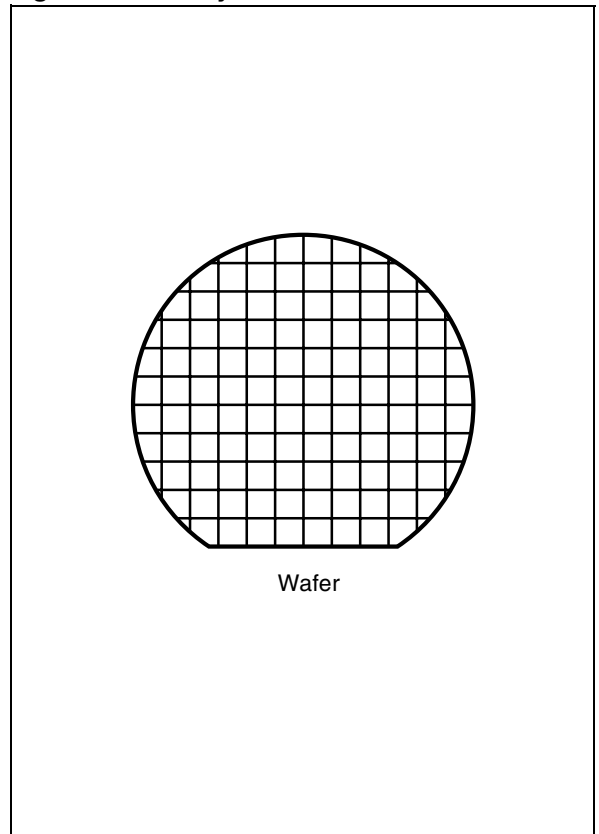

SUMMARY DESCRIPTION

The XRA00 is a full-featured, low-cost integrated circuit for use in radio frequency identification (RFID) transponders (tags) operating in the UHF band of frequencies. It is a 128-bit memory, organized as 8 blocks of 16 bits, as shown in Figure 3.

When connected to its antenna, operating power is derived from RF energy produced by the RFID reader. The XRA00 non-volatile memory enables users to program tags at the point of application, if desired. The XRA00 will respond only after first receiving a valid and appropriate command from the reader.

Based on the EPCglobal class 1b specification, the device provides a fast and flexible anticollision protocol that is robust in the noisy and unpredictable RF conditions that are typical of RFID applications.

Figure 2. Logic Diagram

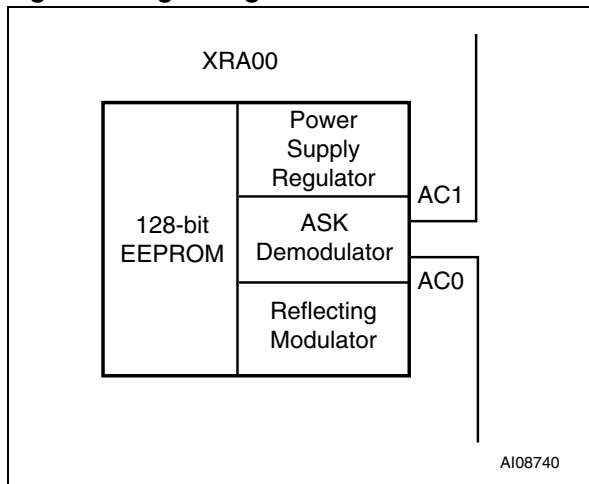

Table 1. Signal Names

AC1	Antenna Pad
AC0	Antenna Pad

Memory Mapping

The XRA00 is organized as 8 blocks of 16 bits as shown in Figure 3. Each bit can be read individually. Writing is performed by block of 16 bits.

Figure 3. XRA00 Memory Mapping

Address	15	8	7	0
0	CRC			
1	ePC			
2	ePC			
3	ePC			
4	ePC			
5	ePC			
6	ePC			
7	Lock Bits		Kill Code	

Note: 1. ST writes part of the ePC code

The XRA00 uses the first block to store the CRC, as defined in the ePC specification. The next six blocks are used to store the 96-bit ePC that is used during the inventory sequence.

The last block is shared between the 8-bit Kill Code and the 8 Lock Bits used to protect the memory data content.

Commands

The XRA00 supports the following commands:

- **SCROLLID:** XRA00, matching data, replies by sending back the entire ID Code. This command is used during the anti-collision sequence.
- **SCROLLALLID:** XRA00, without discrimination, replies by sending back the entire ID Code.
- **PINGID:** This command is used as part of a multi-XRA00 anti-collision sequence. XRA00, matching data sent by the Reader, responds in a specific slot.
- **QUIET:** XRA00, matching data sent by the Reader, enters the Asleep state where it no longer responds to Reader commands. This Asleep state is maintained until an appropriate Talk command is received, or power has been removed.
- **TALK:** XRA00, matching data sent by the Reader, returns to the Awake state where it responds to commands from the Reader.
- **KILL:** XRA00, matching the entire ID Code, 16-bit CRC and the 8-bit Kill Code sent by the

Reader, is permanently deactivated and will no longer respond to Reader queries.

- **ERASEID:** The EraseID command is a bulk erase of the entire memory array.
- **PROGRAMID:** XRA00 programming is accomplished 16 bits at a time. Programming is only allowed if the XRA00 has not been previously locked.
- **VERIFYID:** The VerifyID command is used to verify that all the memory data bits have been programmed correctly.

Initial Dialog for XRA00

The dialogue between the Reader and the XRA00 is conducted through the following consecutive operations:

- Activation of the XRA00 by the UHF operating field of the Reader
 - Transmission of a command by the Reader
 - Transmission of a response by the XRA00
- This technique is called RTF (Reader Talk First).

MODES

USER mode

When the ePC information is written and the lock bits are programmed, the XRA00 is in User mode. In this mode, the XRA00 answers to the anti-collision commands; the ERASEID, PROGRAMMEID and VERIFYID commands are de-activated.

PART NUMBERING

For a list of available options or for further information on this device, please see the current Memory Shortform Catalog. For further information on any aspect of this device, please contact your nearest ST Sales Office, or send your enquiries to the following email address: *ask.memory@st.com*

Table 2. Ordering Information Scheme

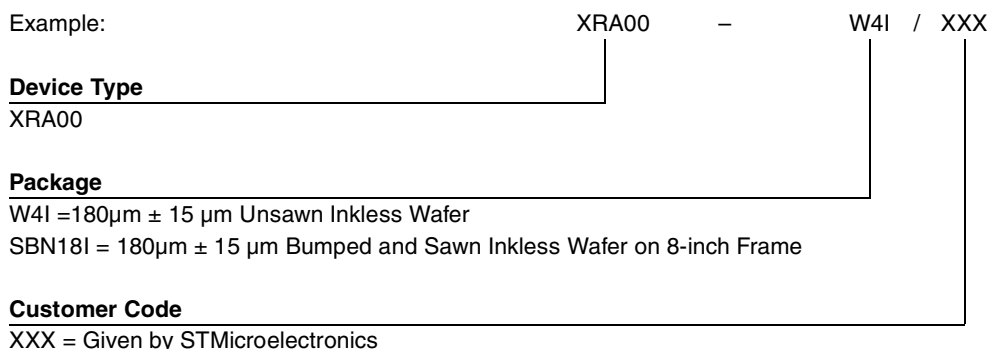

REVISION HISTORY

Table 3. Document Revision History

Date	Version	Revision Details
27-Aug-2003	1.0	First Issue
13-Aug-2004	2.0	Dipole inlay package option removed. Auto-ID changed to EPCglobal. Sawn and Unsawn Wafers changed to Sawn and Unsawn Inkless Wafers

Information furnished is believed to be accurate and reliable. However, STMicroelectronics assumes no responsibility for the consequences of use of such information nor for any infringement of patents or other rights of third parties which may result from its use. No license is granted by implication or otherwise under any patent or patent rights of STMicroelectronics. Specifications mentioned in this publication are subject to change without notice. This publication supersedes and replaces all information previously supplied. STMicroelectronics products are not authorized for use as critical components in life support devices or systems without express written approval of STMicroelectronics.

The ST logo is a registered trademark of STMicroelectronics.
All other names are the property of their respective owners

© 2004 STMicroelectronics - All rights reserved

STMicroelectronics group of companies

Australia - Belgium - Brazil - Canada - China - Czech Republic - Finland - France - Germany - Hong Kong - India - Israel - Italy - Japan - Malaysia - Malta - Morocco - Singapore - Spain - Sweden - Switzerland - United Kingdom - United States of America

www.st.com