

TC5068BP, TC5069BP

C²MOS DIGITAL INTEGRATED CIRCUIT
SILICON MONOLITHIC

TC5068BP, TC5069BP BCD TO 7-SEGMENT LATCH/DECODER/DRIVER

The TC5068BP and TC5069BP are decoders which convert the inputs of BCD codes into the 7-segment display element driving signals. Since the segment output is of an open drain structure with high breakdown voltage P-channel FET, these decoders can directly drive fluorescent display tubes.

Each of four input lines contains a latch controlled by common strobe input, to facilitate static drive. Each BL input is used for forcing all the segments to the OFF state; therefore, the decoders can be applied to the leading zero suppress by combining zero output (When input code is at "0", "H" level is output). The TC5068BP is of a hexadecimal display indicating type, and the TC5069BP is of a BCD display puls "L", "H", "A", "P", "-", and "blank" display indicating type.

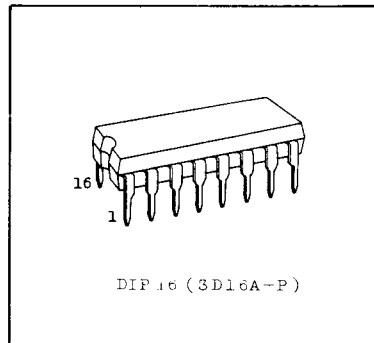

PIN ASSIGNMENT

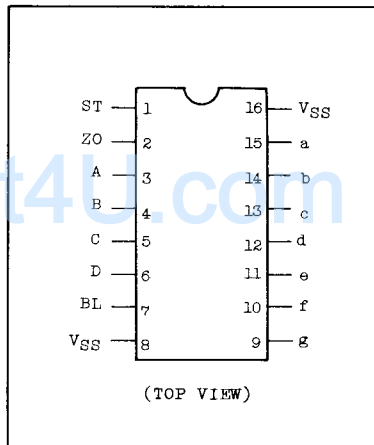

ABSOLUTE MAXIMUM RATINGS

CHARACTERISTIC	SYMBOL	RATING	UNIT
DC Supply Voltage	V _{DD}	V _{SS} -0.5 ~ V _{SS} +20	V
Input Voltage	V _{IN}	V _{SS} -0.5 ~ V _{DD} +0.5	V
Output Voltage *	V _{OUT1}	V _{DD} -50 ~ V _{DD} +0.5	V
	V _{OUT2}	V _{SS} -0.5 ~ V _{DD} +0.5	V
DC Input Current	I _{IN}	±10	mA
Power Dissipation	P _D	300	mW
Operating Temperature Range	T _{opr}	-40 ~ 85	°C
Storage Temperature Range	T _{stg}	-65 ~ 150	°C

* V_{OUT1} is applied to segment output, and V_{OUT2} to zero output.

BLOCK DIAGRAM

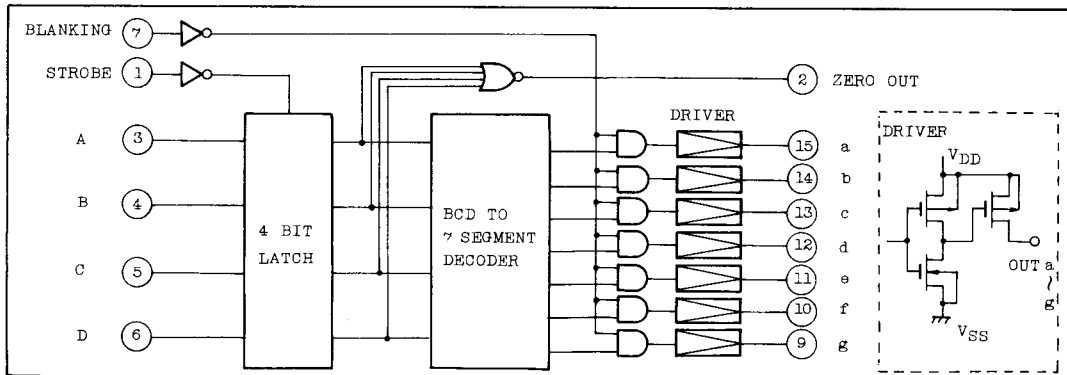

TRUTH TABLE

INPUTS						OUTPUTS													ZERO OUT	
						TC5068BP Δ							TC5069BP Δ							
ST	BL	D	C	B	A	a	b	c	d	e	f	g	a	b	c	d	e	f	g	
※	H	※	※	※	※	L	L	L	L	L	L	L	L	L	L	L	L	L	L	☆
H	L	L	L	L	L	H	H	H	H	H	H	L	H	H	H	H	H	H	L	H
H	L	L	L	L	H	L	H	H	L	L	L	L	L	H	H	L	L	L	L	L
H	L	L	L	H	L	H	H	L	H	H	L	H	H	H	L	H	H	L	H	L
H	L	L	L	H	H	H	H	H	H	L	L	H	H	H	H	H	L	L	H	L
H	L	L	H	L	L	L	H	H	L	L	H	H	L	H	H	L	L	H	H	L
H	L	L	H	L	H	H	L	H	H	L	H	H	H	L	H	H	L	H	H	L
H	L	L	H	H	L	H	H	H	H	H	H	H	H	L	H	H	H	H	H	L
H	L	L	H	H	H	H	H	H	L	L	H	L	H	H	H	L	L	H	H	L
H	L	L	H	L	H	L	H	H	L	H	H	H	L	L	L	H	H	H	L	L
H	L	L	H	L	H	L	L	H	H	H	H	H	L	L	L	L	L	L	L	L
H	L	L	H	L	H	L	L	H	H	H	H	H	L	L	L	L	L	L	L	L
H	L	L	H	L	H	L	L	H	H	H	H	H	L	L	L	L	L	L	L	L
H	L	L	H	L	H	L	L	H	H	H	H	H	L	L	L	L	L	L	L	L
H	L	L	H	L	H	L	L	H	H	H	H	H	L	L	L	L	L	L	L	L
L	L	※	※	※	※								$\Delta\Delta$							

- ※ : Don't care
- ☆ : Undetermined
- $\Delta\Delta$: Depends Upon the BCD code previously applied when ST="H"
- Δ : Required pull down resistor "RL"

DISPLAY INDICATING TYPE

TC5068BP	0	1	2	3	4	5	6	7	8	9	10	11	12	13	14	15
	0	1	2	3	4	5	6	7	8	9	A	B	C	d	E	F
TC5069BP	0	1	2	3	4	5	6	7	8	9	L	H	A	P	-	BLANK

RECOMMENDED OPERATING CONDITIONS (V_{SS}=0V)

項 目	記 号	MIN	TYP	MAX	単 位
電 源 電 圧	V _{DD}	3	—	18	V
入 力 電 圧	V _{IN}	0	—	V _{DD}	V

TC5068BP, TC5069BP

ELECTRICAL CHARACTERISTICS (V_{SS}=0V)

CHARACTERISTIC	SYMBOL	TEST CONDITION	V _{DD} (V)	-40°C		25°C			85°C		UNIT	
				MIN.	MAX.	MIN.	TYP.	MAX.	MIN.	MAX.		
High Level Output Voltage	V _{OH}	I _{OUT} < 1μA V _{IN} =V _{SS} or V _{DD}	5	4.95	-	4.95	5.00	-	4.95	-	V	
			10	9.95	-	9.95	10.00	-	9.95	-		
			15	14.95	-	14.95	15.00	-	14.95	-		
Low Level Output Voltage (ZERO OUT)	V _{OL}	I _{OUT} < 1μA V _{IN} =V _{SS} or V _{DD}	5	-	0.05	-	0.00	0.05	-	0.05	V	
			10	-	0.05	-	0.00	0.05	-	0.05		
			15	-	0.05	-	0.00	0.05	-	0.05		
High Level Output Current (Segment OUT)	I _{OH}	VOH= 3V(V _{DD} -2V)	5	-6	-	-5	-	-	-4	-	mA	
		VOH= 2V(V _{DD} -3V)	5	-9	-	-8	-	-	-6	-		
		VOH= 7V(V _{DD} -3V)	10	-12	-	-10	-	-	-8	-		
		VOH=12V(V _{DD} -3V)	15	-17	-	-15	-	-	-12	-		
		V _{IN} =V _{SS} or V _{DD}										
High Level Output Current (Zero OUT)	I _{OH}	VOH= 4.6V	5	-0.2	-	-0.16	-	-	-0.12	-	mA	
		VOH= 9.5V	10	-0.5	-	-0.4	-	-	-0.3	-		
		VOH=13.5V	15	-1.4	-	-1.2	-	-	-1.0	-		
		V _{IN} =V _{SS} or V _{DD}										
Low Level Output Current (Zero OUT)	I _{OL}	VOL=0.4V	5	0.52	-	0.44	-	-	0.36	-	mA	
		VOL=0.5V	10	1.3	-	1.1	-	-	0.9	-		
		VOL=1.5V	15	3.6	-	3.0	-	-	2.4	-		
		V _{IN} =V _{SS} or V _{DD}										
High Level Input Voltage	V _{IH} *	V _{OUT} =0.5, 4.5V	5	3.5	-	3.5	2.75	-	3.5	-	V	
		V _{OUT} =1.0, 9.0V	10	7.0	-	7.0	5.5	-	7.0	-		
		V _{OUT} =1.5, 13.5V	15	11.0	-	11.0	8.25	-	11.0	-		
		I _{OUT} < 1μA										
Low Level Input Voltage	V _{IL} *	V _{OUT} =0.5, 4.5V	5	-	1.5	-	2.25	1.5	-	1.5	V	
		V _{OUT} =1.0, 9.0V	10	-	3.0	-	4.5	3.0	-	3.0		
		V _{OUT} =1.5, 13.5V	15	-	4.0	-	6.75	4.0	-	4.0		
		I _{OUT} < 1μA										
Output Off-leak Current (Segment OUT)	I _{OFF}	V _{OUT} =0V	15	-	-3	-	-0.01	-3	-	-10	μA	
		V _{OUT} =-30V	15	-	-10	-	-1	-10	-	-20		
Input Current	"H" Level	I _{IH}	V _{IH} =18V	18	-	0.3	-	10 ⁻⁵	0.3	-	1.0	μA
	"L" Level	I _{IL}	V _{IL} =0V	18	-	-0.3	-	-10 ⁻⁵	-0.3	-	-1.0	
Quiescent Supply Current	I _{DD}	V _{IN} =V _{SS} or V _{DD}	5	-	20	-	0.005	20	-	150	μA	
		Outputs Open	10	-	40	-	0.010	40	-	300		
		**	15	-	80	-	0.015	80	-	600		

* R_L = 20 kΩ

** All valid input combinations.

SWITCHING CHARACTERISTICS (Ta=25°C, VSS=0V, CL=50pF)

CHARACTERISTIC	SYMBOL	TEST CONDITION	VDD	MIN.	TYP.	MAX.	UNIT
			(V)				
Output Rise Time (SEGMENT OUT)	t _{TLH}	R _L = 1 kΩ	5	-	100	200	ns
			10	-	50	100	
			15	-	40	80	
Output Rise Time (ZERO OUT)	t _{TLH}		5	-	130	400	ns
			10	-	65	200	
			15	-	50	160	
Output Fall Time (ZERO OUT)	t _{THL}		5	-	100	200	ns
			10	-	50	100	
			15	-	40	80	
(Low-High) Propagation Delay Time (A,B,C,D-SEGMENT OUT)	t _{pLH}	R _L = 1 kΩ	5	-	750	1800	ns
			10	-	300	600	
			15	-	200	400	
(High-Low) Propagation Delay Time (A,B,C,D-SEGMENT OUT)	t _{pHL}	R _L = 1 kΩ	5	-	750	1800	ns
			10	-	300	600	
			15	-	200	400	
(Low-High) Propagation Delay Time (A,B,C,D-ZERO OUT)	t _{pLH}		5	-	250	500	ns
			10	-	125	250	
			15	-	100	200	
(High-Low) Propagation Delay Time (A,B,C,D-ZERO OUT)	t _{pHL}		5	-	250	500	ns
			10	-	125	250	
			15	-	100	200	
(Low-High) Propagation Delay Time (BL-SEGMENT OUT)	t _{pLH}	R _L = 1 kΩ	5	-	200	400	ns
			10	-	100	200	
			15	-	80	160	
(High-Low) Propagation Delay Time (BL-SEGMENT OUT)	t _{pHL}	R _L = 1 kΩ	5	-	200	400	ns
			10	-	100	200	
			15	-	80	160	
Minimum ST Pulse Width	t _w (ST)		5	-	60	200	ns
			10	-	30	100	
			15	-	25	80	
Minimum Setup Time (ST-A,B,C,D IN)	t _{SU}		5	-	35	200	ns
			10	-	20	100	
			15	-	10	80	
Minimum Hold Time (ST-A,B,C,D IN)	t _H		5	-	-	100	ns
			10	-	-	60	
			15	-	-	40	
Input Capacitance	C _{IN}			-	5	7.5	pF

TC5068BP, TC5069BP

SWITCHING TIME TEST CIRCUIT

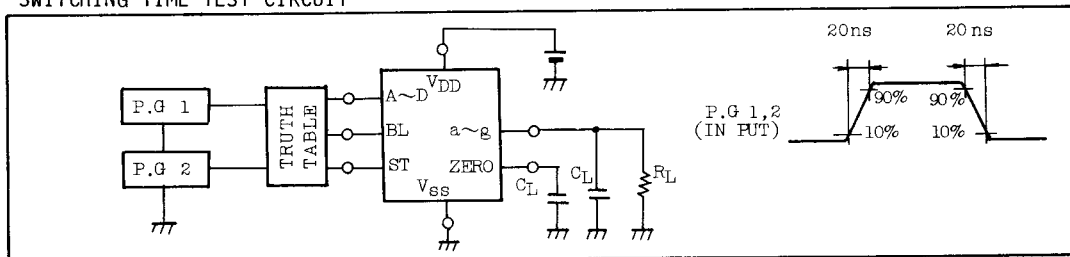

SWITCHING TIME TEST WAVEFORM

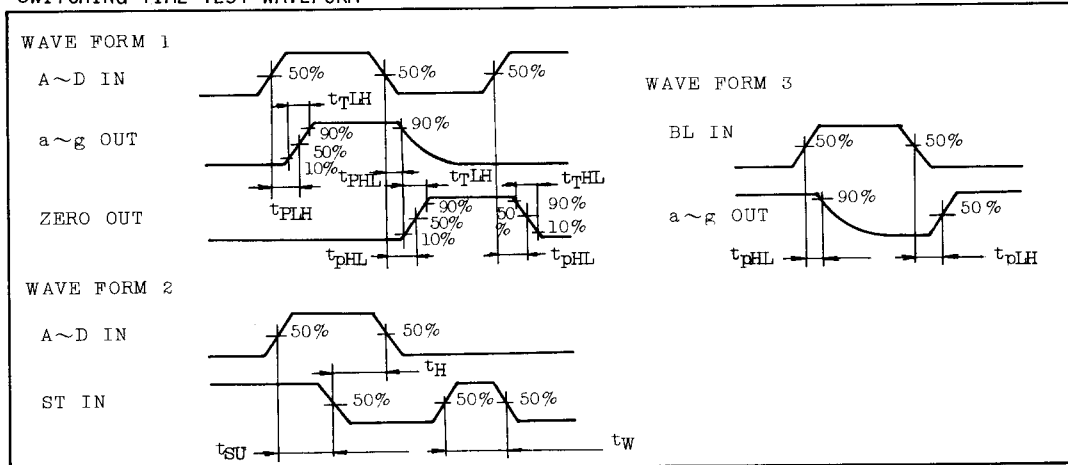

APPLICATION EXAMPLE

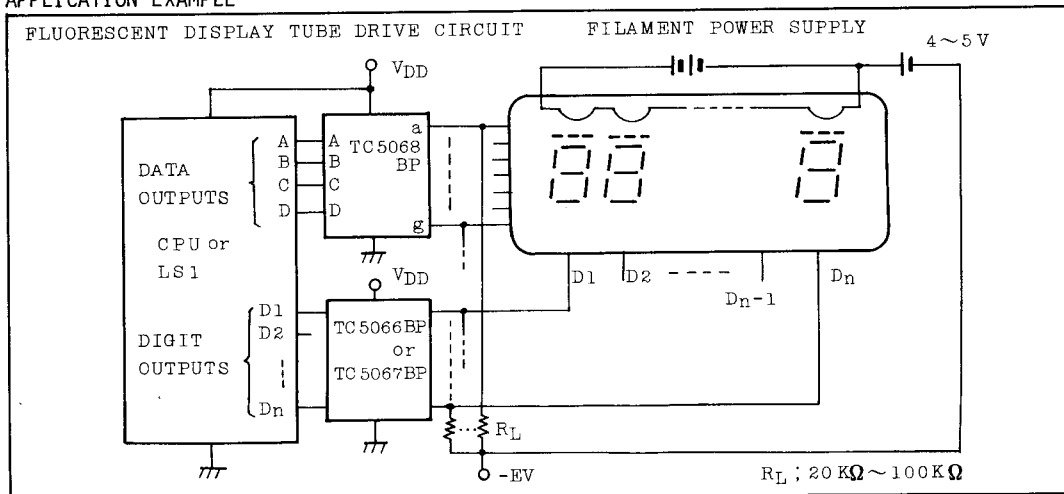

APPLICATION EXAMPLE

