	<p><b>16Mbyte(4Mx36) 72-pin SIMM, EDO with Parity Mode, 2K/4K Ref. 5V</b></p> <p><b>Part No. HMD4M36M9EG , HMD4M36M9EAG</b></p>
-----------------------------------------------------------------------------------	---------------------------------------------------------------------------------------------------------------------------------

**GENERAL DESCRIPTION**

The HMD4M36M9EG is a 4M x 36 bit dynamic RAM high-density memory module. The module HMD4M36M8E consists of eight CMOS 4M x 4 bit DRAMs in 24-pin SOJ packages and one CMOS 4M x 4 bit Quad /CAS DRAM in 28-pin SOJ package mounted on a 72-pin, double-sided, FR-4-printed circuit board. A 0.1uF or 0.22uF decoupling capacitor is mounted on the printed circuit board for each DRAM. The module is a single In-line memory module with edge connections and is intended for mounting in to 72-pin edge connector sockets. All module components may be powered from a single 5V DC power supply and all inputs and outputs are TTL -compatible.

**FEATURES**

- w Part Identification
  - HMD4M36M9E----2048 Cycles/32ms Ref. Solder
  - HMD4M36M9EG- 2048 Cycles/32ms Ref. Gold
  - HMD4M36M9EA----4096 Cycles/64ms Ref. Solder
  - HMD4M36M9EAG- 4096 Cycles/64ms Ref. Gold
- w Access times : 50, 60ns
- w High-density 16MByte design
- w Single + 5V ±0.5V power supply
- w JEDEC standard pinout
- w EDO mode operation
- w /CAS-before-/RAS refresh capability
- w TTL compatible inputs and outputs
- w FR4-PCB design

**OPTIONS                      MARKING**

- w Timing
 

50ns access	-5
60ns access	-6
- w Packages
 

72-pin SIMM	M
-------------	---

**PRESENCE DETECT PINS**

Pin	50ns	60ns
PD1	Vss	Vss
PD2	NC	NC
PD3	Vss	NC
PD4	Vss	NC

**PERFORMANCE RANGE**

Speed	tRAC	tCAC	tRC	tHPC
5	50ns	13ns	90ns	26ns
6	60ns	15ns	110ns	30ns

**PIN ASSIGNMENT**

PIN	SYMBOL	PIN	SYMBOL	PIN	SYMBOL
1	Vss	25	DQ24	49	DQ9
2	DQ0	26	DQ7	50	DQ27
3	DQ18	27	DQ25	51	DQ10
4	DQ1	28	A7	52	DQ28
5	DQ19	29	A11	53	DQ11
6	DQ2	30	Vcc	54	DQ29
7	DQ20	31	A8	55	DQ12
8	DQ3	32	A9	56	DQ30
9	DQ21	33	NC	57	DQ13
10	Vcc	34	/RAS2	58	DQ31
11	NC	35	DQ26	59	Vcc
12	A0	36	DQ8	60	DQ32
13	A1	37	DQ17	61	DQ14
14	A2	38	DQ35	62	DQ33
15	A3	39	Vss	63	DQ15
16	A4	40	/CAS0	64	DQ34
17	A5	41	/CAS2	65	DQ16
18	A6	42	/CAS3	66	NC
19	A10	43	/CAS1	67	Vss
20	DQ4	44	/RAS0	68	PD2
21	DQ22	45	NC	69	PD3
22	DQ5	46	NC	70	PD4
23	DQ23	47	/WE	71	NC
24	DQ6	48	NC	72	Vss

A0-A11 : Address Input (4K Ref.)

A0-A10 : Address Input (2K Ref)

\*Note:A11 is used for only HMD4M36M9EA

FUNCTIONAL BLOCK DIAGRAM

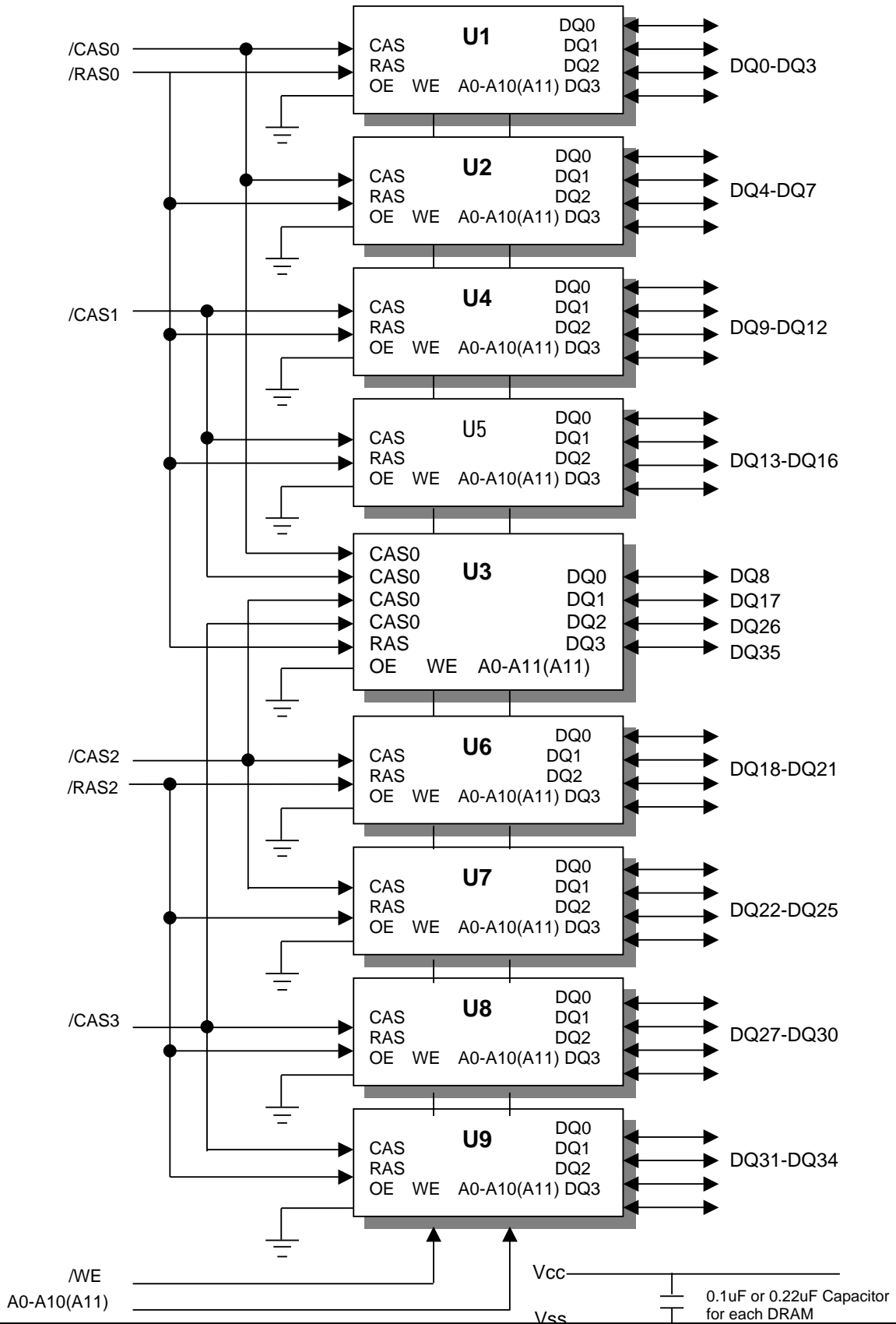

**ABSOLUTE MAXIMUM RATINGS**

PARAMETER	SYMBOL	RATING
Voltage on Any Pin Relative to V <sub>SS</sub>	V <sub>IN,OUT</sub>	-1V to 7.0V
Voltage on V <sub>CC</sub> Supply Relative to V <sub>SS</sub>	V <sub>CC</sub>	-1V to 7.0V
Power Dissipation	P <sub>D</sub>	9W
Storage Temperature	T <sub>STG</sub>	-55°C to 150°C
Short Circuit Output Current	I <sub>OS</sub>	50mA

w Permanent device damage may occur if " Absolute Maximum Ratings" are exceeded. Functional operation should be restricted to the conditions as detailed in the operational sections of this data sheet. Exposure to absolute maximum rating conditions for extended periods may affect device reliability.

**RECOMMENDED DC OPERATING CONDITIONS**

( Voltage reference to V<sub>SS</sub>, T<sub>A</sub>=0 to 70 ° C )

PARAMETER	SYMBOL	MIN	TYP.	MAX	UNIT
Supply Voltage	V <sub>CC</sub>	4.5	5.0	5.5	V
Ground	V <sub>SS</sub>	0	0	0	V
Input High Voltage	V <sub>IH</sub>	2.4	-	V <sub>CC</sub> +1	V
Input Low Voltage	V <sub>IL</sub>	-1.0	-	0.8	V

**DC AND OPERATING CHARACTERISTICS**

SYMBOL	SPEED	MIN	MAX	UNITS
I <sub>CC1</sub>	-5	-	990	mA
	-6	-	900	mA
I <sub>CC2</sub>		-	18	mA
I <sub>CC3</sub>	-5	-	990	mA
	-6	-	900	mA
I <sub>CC4</sub>	-5	-	990	mA
	-6	-	900	mA
I <sub>CC5</sub>		-	9	mA
I <sub>CC6</sub>	-5	-	990	mA
	-6	-	900	mA
I <sub>I(L)</sub>		-40	45	μA
I <sub>O(L)</sub>		-5	5	μA
V <sub>OH</sub>		2.4	-	V
V <sub>OL</sub>		-	0.4	V

I<sub>CC1</sub> : Operating Current \* (/RAS , /CAS , Address cycling @t<sub>RC</sub>=min.)

I<sub>CC2</sub> : Standby Current ( /RAS=/CAS=V<sub>IH</sub> )

I<sub>CC3</sub> : /RAS Only Refresh Current \* ( /CAS=V<sub>IH</sub> , /RAS, Address cycling @t<sub>RC</sub>=min )

I<sub>CC4</sub> : Fast Page Mode Current \* (/RAS=V<sub>IL</sub> , /CAS, Address cycling @t<sub>PC</sub>=min )

I<sub>CC5</sub> : Standby Current (/RAS=/CAS=V<sub>CC</sub>-0.2V )

$I_{CC6}$  : /CAS-Before-/RAS Refresh Current \* (/RAS and /CAS cycling @ $t_{RC}=\min$ )

$I_{IL}$  : Input Leakage Current (Any input  $0V \leq V_{IN} \leq 6.5V$ , all other pins not under test =  $0V$ )

$I_{OL}$  : Output Leakage Current (Data out is disabled,  $0V \leq V_{OUT} \leq 5.5V$ )

$V_{OH}$  : Output High Voltage Level ( $I_{OH} = -5mA$ )

$V_{OL}$  : Output Low Voltage Level ( $I_{OL} = 4.2mA$ )

\* **NOTE:**  $I_{CC1}$ ,  $I_{CC3}$ ,  $I_{CC4}$  and  $I_{CC6}$  are dependent on output loading and cycle rates. Specified values are obtained with the output open.  $I_{CC}$  is specified as an average current. In  $I_{CC1}$  and  $I_{CC3}$ , address can be changed maximum once while /RAS= $V_{IL}$ . In  $I_{CC4}$ , address can be changed maximum once within one page mode cycle.

## CAPACITANCE ( $T_A=25^\circ C$ , $V_{CC} = 5V$ , $f = 1Mz$ )

DESCRIPTION	SYMBOL	MIN	MAX	UNITS
Input Capacitance (A0-A10)	$C_{IN1}$	-	65	pF
Input Capacitance (/W)	$C_{IN2}$	-	80	pF
Input Capacitance (/RAS0)	$C_{IN3}$	-	50	pF
Input Capacitance (/CAS0-/CAS3)	$C_{IN4}$	-	40	pF
Input/Output Capacitance (DQ0-31)	$C_{DQ1}$	-	20	pF

## AC CHARACTERISTICS ( $0^\circ C \leq T_A \leq 70^\circ C$ , $V_{CC} = 5V \pm 10\%$ , See notes 1,2.)

STANDARD OPERATION	SYMBOL	-5		-6		UNIT
		MIN	MAX	MIN	MAX	
Random read or write cycle time	$t_{RC}$	90		110		ns
Access time from $\overline{RAS}$	$t_{RAC}$		50		60	ns
Access time from $\overline{CAS}$	$t_{CAC}$		13		15	ns
Access time from column address	$t_{AA}$		25		30	ns
$\overline{CAS}$ to output in Low-Z	$t_{CLZ}$	3		3		ns
Output buffer turn-off delay	$t_{OFF}$	3	13	3	15	ns
Transition time (rise and fall)	$t_T$	2	50	2	50	ns
/RAS precharge time	$t_{RP}$	30		40		ns
/RAS pulse width	$t_{RAS}$	50	10K	60	10K	ns
/RAS hold time	$t_{RSH}$	13		15		ns
/CAS hold time	$t_{CSH}$	38		45		ns
/CAS pulse width	$t_{CAS}$	8	10K	10	10K	ns
/RAS to /CAS delay time	$t_{RCD}$	20	37	20	45	ns
/RAS to column address delay time	$t_{RAD}$	15	25	15	30	ns
/CAS to /RAS precharge time	$t_{CRP}$	5		5		ns
Row address set-up time	$t_{ASR}$	0		0		ns
Row address hold time	$t_{RAH}$	10		10		ns
Column address set-up time	$t_{ASC}$	0		0		ns

Column address hold time	$t_{CAH}$	8		10		ns
Column Address to /RAS lead time	$t_{RAL}$	25		30		ns
Read command set-up time	$t_{RCS}$	0		0		ns
Read command hold referenced to /CAS	$t_{RCH}$	0		0		ns
Read command hold referenced to /RAS	$t_{RRH}$	0		0		ns
Write command hold time	$t_{WCH}$	10		10		ns
Write command hold referenced to /RAS	$t_{WCR}$	50		50		ns
Write command pulse width	$t_{WCP}$	10		10		ns
Write command to /RAS lead time	$t_{RWL}$	13		15		ns
Write command to /CAS lead time	$t_{CWL}$	8		10		ns
Data-in set-up time	$t_{DS}$	0		0		ns
Data-in hold time	$t_{DH}$	8		10		ns
Data-in hold referenced to /RAS	$t_{DHR}$	50		50		ns
Refresh period	$t_{REF}$		32		32	ns
Write command set-up time	$t_{WCS}$	0		0		ns
/CAS setup time (C-B-R refresh)	$t_{CSR}$	5		5		ns
/CAS hold time (C-B-R refresh)	$t_{CHR}$	10		10		ns
/RAS precharge to /CAS hold time	$t_{RPC}$	5		5		ns
Access time from /CAS precharge	$t_{CPA}$		30		35	ns
Fast page mode cycle time	$t_{PC}$	40		40		ns
/CAS precharge time (Fast page)	$t_{CP}$	8		10		ns
/RAS pulse width (Fast page )	$t_{RASP}$	50	200K	60	200K	ns
/W to /RAS precharge time (C-B-R refresh)	$t_{WRP}$	10		10		ns
/W to /RAS hold time (C-B-R refresh)	$t_{WRH}$	10		10		ns
/CAS precharge(C-B-R counter test)	$t_{CPT}$	20		20		ns

**NOTES**

1. An initial pause of 200 $\mu$ s is required after power-up followed by any 8 /RAS-only or /CAS-before-/RAS refresh cycles before proper device operation is achieved.
2.  $V_{IH(min)}$  and  $V_{IL(max)}$  are reference levels for measuring timing of input signals. Transition times are measured between  $V_{IH(min)}$  and  $V_{IL(max)}$  and are assumed to be 5ns for all inputs.
3. Measured with a load equivalent to 2TTL loads and 100pF
4. Operation within the  $t_{RCD(max)}$  limit insures that  $t_{RAC(max)}$  can be met.  $t_{RCD(max)}$  is specified as a reference point only. If  $t_{RCD}$  is greater than the specified  $t_{RCD(max)}$  limit, then access time is controlled exclusively by  $t_{CAC}$ .
5. Assumes that  $t_{RCD} \geq t_{RCD(max)}$
6.  $t_{AR}$ ,  $t_{WCR}$ ,  $t_{DHR}$  are referenced to  $t_{RAD(max)}$
7. This parameter defines the time at which the output achieves the open circuit condition and is not referenced to  $V_{OH}$  or  $V_{OL}$ .
8.  $t_{WCS}$ ,  $t_{RWD}$ ,  $t_{CWD}$  and  $t_{AWD}$  are non restrictive operating parameter.  
They are included in the data sheet as electrical characteristic only. If  $t_{WCS} \geq t_{WCS(min)}$  the cycle is an early write cycle and the data out pin will remain high impedance for the duration of the cycle.
9. Either  $t_{RCH}$  or  $t_{RRH}$  must be satisfied for a read cycle.
10. These parameters are referenced to the /CAS leading edge in early write cycles and to the /W leading edge in read-write cycles.
11. Operation within the  $t_{RAD(max)}$  limit insures that  $t_{RAC(max)}$  can be met.  $t_{RAD(max)}$  is specified as a reference point only. If  $t_{RAD}$  is greater than the specified  $t_{RAD(max)}$  limit, then access time is controlled by  $t_{AA}$ .

PACKAGING INFORMATION

SIMM Design

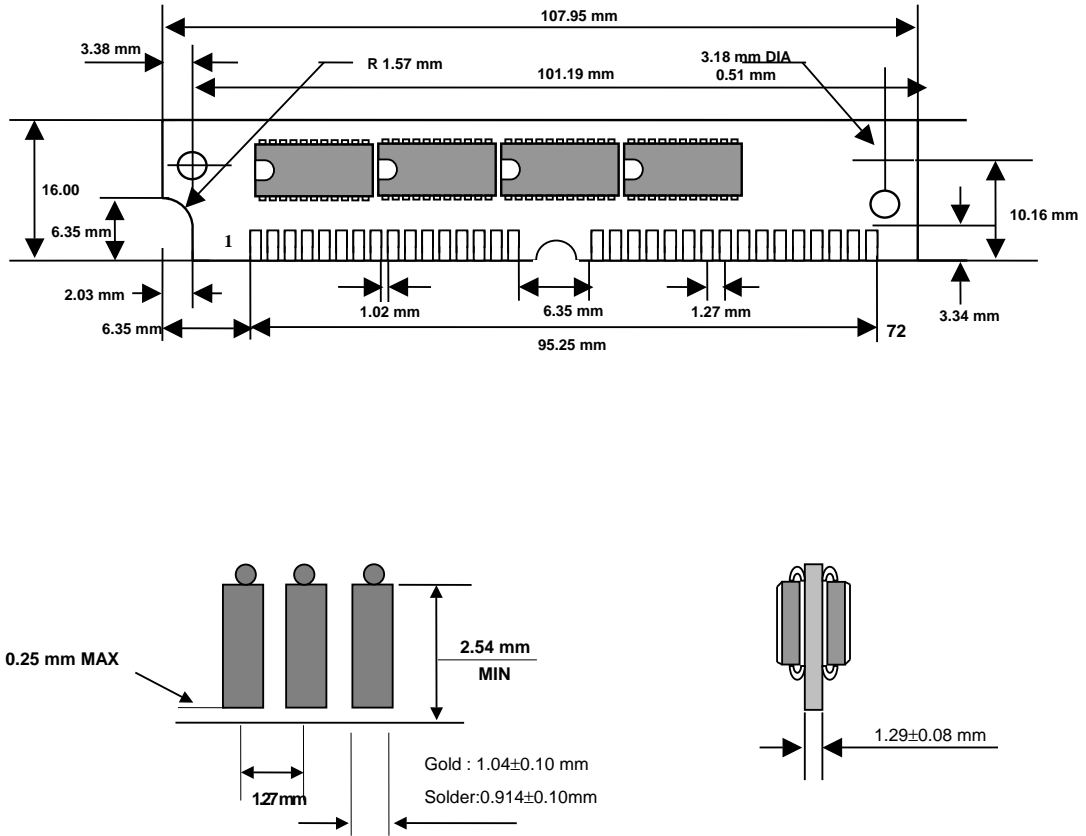

ORDERING INFORMATION

Part Number	Density	Org.	Package	Refresh Cycle	Vcc	SPEED
HMD4M36M9EG-5	16MByte	4MX 32bit	72 Pin-SIMM	2,048 Cycles 32ms Ref.	5.0V	50ns
HMD4M36M9EG-6	16MByte	4MX 32bit	72 Pin-SIMM	2,048 Cycles 32ms Ref.	5.0V	60ns
HMD4M36M9EAG-5	16MByte	4MX 32bit	72 Pin-SIMM	4,096 Cycle 64ms Ref.	5.0V	50ns

---

<b>HMD4M36M9EAG-6</b>	16MByte	4MX 32bit	72 Pin-SIMM	4,096 Cycle 64ms Ref.	5.0V	60ns
-----------------------	---------	-----------	-------------	--------------------------	------	------