

MECHANICAL DATA

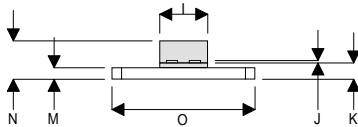
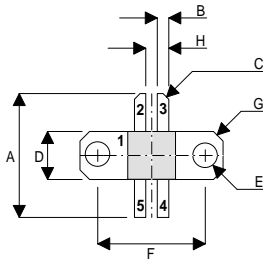

DQ

PIN 1	SOURCE (COMMON)	PIN 2	DRAIN 1
PIN 3	DRAIN 2	PIN 4	GATE 2
PIN 5	GATE 1		

DIM	mm	Tol.	Inches	Tol.
A	16.38	0.26	0.645	0.010
B	1.52	0.13	0.060	0.005
C	45°	5°	45°	5°
D	6.35	0.13	0.250	0.005
E	3.30	0.13	0.130	0.005
F	14.22	0.13	0.560	0.005
G	1.27 x 45°	0.13	0.05 x 45°	0.005
H	1.52	0.13	0.060	0.005
I	6.35	0.13	0.250	0.005
J	0.13	0.02	0.005	0.001
K	2.16	0.13	0.085	0.005
M	1.52	0.13	0.060	0.005
N	5.08	MAX	0.200	MAX
O	18.90	0.13	0.744	0.005

**GOLD METALLISED
MULTI-PURPOSE SILICON
DMOS RF FET
40W – 28V – 500MHz
PUSH-PULL**

FEATURES

- SIMPLIFIED AMPLIFIER DESIGN
- SUITABLE FOR BROAD BAND APPLICATIONS
- VERY LOW C_{rss}
- USEFUL P_O AT 1GHz
- LOW NOISE
- HIGH GAIN – 13 dB MINIMUM

APPLICATIONS

- VHF/UHF COMMUNICATIONS
from 1 MHz to 1 GHz

ABSOLUTE MAXIMUM RATINGS ($T_{case} = 25^{\circ}C$ unless otherwise stated)

P_D	Power Dissipation	100W
BV_{DSS}	Drain – Source Breakdown Voltage *	70V
BV_{GSS}	Gate – Source Breakdown Voltage *	$\pm 20V$
$I_{D(sat)}$	Drain Current *	5A
T_{stg}	Storage Temperature	-65 to $150^{\circ}C$
T_j	Maximum Operating Junction Temperature	$200^{\circ}C$

* Per Side

ELECTRICAL CHARACTERISTICS (T_{case} = 25°C unless otherwise stated)

Parameter	Test Conditions	Min.	Typ.	Max.	Unit
PER SIDE					
B _V DSS	Drain–Source Breakdown Voltage V _{GS} = 0 I _D = 100mA	70			V
I _{DSS}	Zero Gate Voltage Drain Current V _{DS} = 28V V _{GS} = 0			1	mA
I _{GSS}	Gate Leakage Current V _{GS} = 20V V _{DS} = 0			1	μA
V _{GS(th)}	Gate Threshold Voltage* I _D = 10mA V _{DS} = V _{GS}	1		7	V
g _{fs}	Forward Transconductance* V _{DS} = 10V I _D = 1A	0.8			S
TOTAL DEVICE					
G _{PS}	Common Source Power Gain P _O = 40W	13			dB
η	Drain Efficiency V _{DS} = 28V I _{DQ} = 0.4A	50			%
V _{SWR}	Load Mismatch Tolerance f = 400MHz	20:1			—
PER SIDE					
C _{iss}	Input Capacitance V _{DS} = 28V V _{GS} = -5V f = 1MHz			60	pF
C _{oss}	Output Capacitance V _{DS} = 28V V _{GS} = 0 f = 1MHz			30	pF
C _{rss}	Reverse Transfer Capacitance V _{DS} = 28V V _{GS} = 0 f = 1MHz			2.5	pF

* Pulse Test: Pulse Duration = 300 μs , Duty Cycle ≤ 2%

HAZARDOUS MATERIAL WARNING

The ceramic portion of the device between leads and metal flange is beryllium oxide. Beryllium oxide dust is highly toxic and care must be taken during handling and mounting to avoid damage to this area.

THESE DEVICES MUST NEVER BE THROWN AWAY WITH GENERAL INDUSTRIAL OR DOMESTIC WASTE.

THERMAL DATA

R _{THj-case}	Thermal Resistance Junction – Case	Max. 1.75°C / W
-----------------------	------------------------------------	-----------------

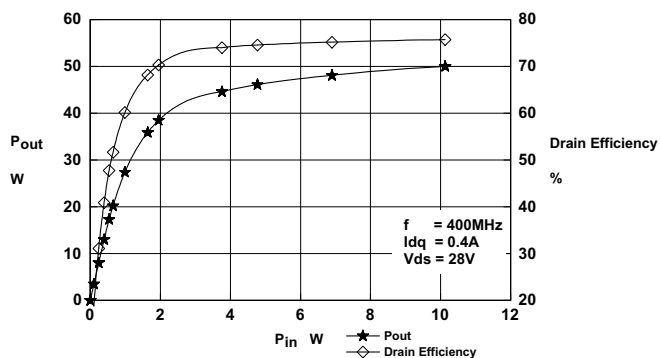

Figure 1

Power Output and efficiency vs. Power Input.

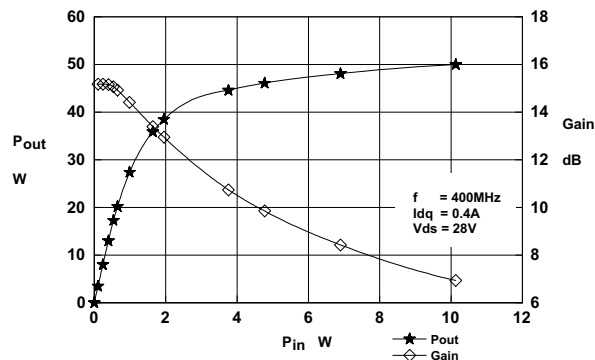

Figure 2

Power Output and Gain vs. Power Input.

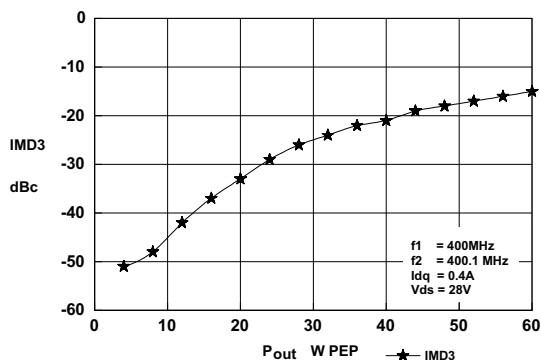

Figure 3

IMD Vs. Output Power.

OPTIMUM SOURCE AND LOAD IMPEDANCE

Frequency MHz	Z _S Ω	Z _L Ω
400MHZ	10.7 - j35.4	13.8 - j22.2

Typical S Parameters

! V_{DS} = 28V, I_{DQ} = 1A
 # MHZ S MA R 50

!Freq !MHz	S11 mag	S11 ang	S21 mag	S21 ang	S12 mag	S12 ang	S22 mag	S22 ang
100	0.767	-135	22.646	88	0.0155	9	0.531	-103
200	0.813	-153	10.116	57	0.0099	4	0.692	-131
300	0.841	-161	5.623	39	0.0076	49	0.794	-143
400	0.861	-169	3.548	25	0.013	79	0.841	-151
500	0.882	-175	2.82	20	0.021	78	0.875	-156
600	0.902	180	2.093	14	0.0285	78	0.91	-161
700	0.923	174	1.365	9	0.0376	77	0.944	-166
800	0.912	170	1.096	2	0.0457	66	0.944	-170
900	0.923	164	0.902	-3	0.0484	66	0.933	-176
1000	0.923	161	0.724	-4	0.0596	64	0.944	-177

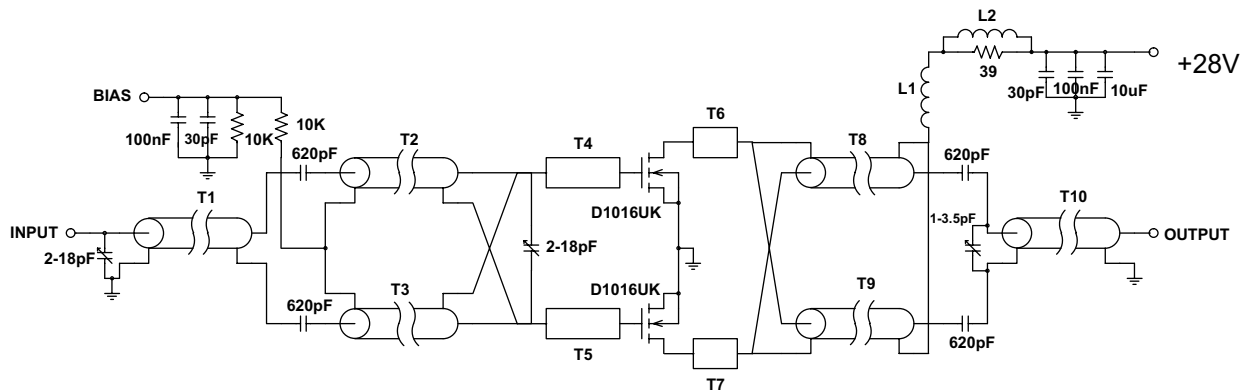

TEST FIXTURE

Substrate 1.6mm FR4
All microstrip lines $W = 2.5\text{mm}$

T1	45mm 50 OHM UT34 semi-rigid coax
T2, T3	55mm 50 OHM UT 34 semi-rigid coax
T4, T5	25mm microstrip line
T6, T7	10mm microstrip line
T8, T9	45mm 25 OHM UT 34-25 semi-rigid coax
T10	60mm 50OHM UT34 semi-rigid coax
L1	4 turns 19swg enamelled copper wire, 7mm i.d.
L2	2.5 turns of 19swg enamelled copper wire on T50-6 ferrite toroid