



H78LXXAM / BM

H78LXXAA / BA

3-TERMINAL POSITIVE VOLTAGE REGULATORS

Description

These regulators employ internal current-limiting and thermal-shutdown, making them essentially indestructible. They can deliver up to 100mA output current.

Features

- Maximum Output Current of 100mA ($T_c=25^\circ\text{C}$)
- Internal Short-Circuit Current Limiting
- Internal Thermal Overload Protection
- TO-92 & SOT-89 Package

Absolute Maximum Ratings

($T_a=25^\circ\text{C}$, Unless Otherwise Specified)

Characteristic	Symbol	Rating	Unit	
Input Voltage	V_{IN}	40	V	
Power Dissipation	P_D	TO-92	700	mW
		SOT-89	500	mW
Operating Temperature	T_{opr}	-30 to 85	$^\circ\text{C}$	
Storage Temperature	T_{stg}	-55 to 150	$^\circ\text{C}$	
Junction Temperature	T_j	150	$^\circ\text{C}$	
Thermal Resistance	$R_{th(j-a)}$	208	$^\circ\text{C/W}$	

H78LXX Series Pin Assignment

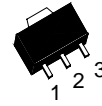

3-Lead Plastic **SOT-89**
Package Code: M
Pin 1: V_{OUT}
Pin 2: GND
Pin 3: V_{IN}

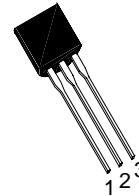

3-Lead Plastic **TO-92**
Package Code: A
Pin 1: V_{OUT}
Pin 2: GND
Pin 3: V_{IN}

Typical Application

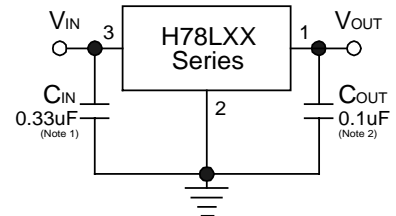

Note 1: C_{IN} is required if regulator is located an appreciable distance from power supply filter.

Note 2: C_{OUT} is not needed for stability; however, it does improve transient response. Values of less than 0.1uF could cause instability.

Schematic Diagram & Equivalent Circuit

Schematic Diagram

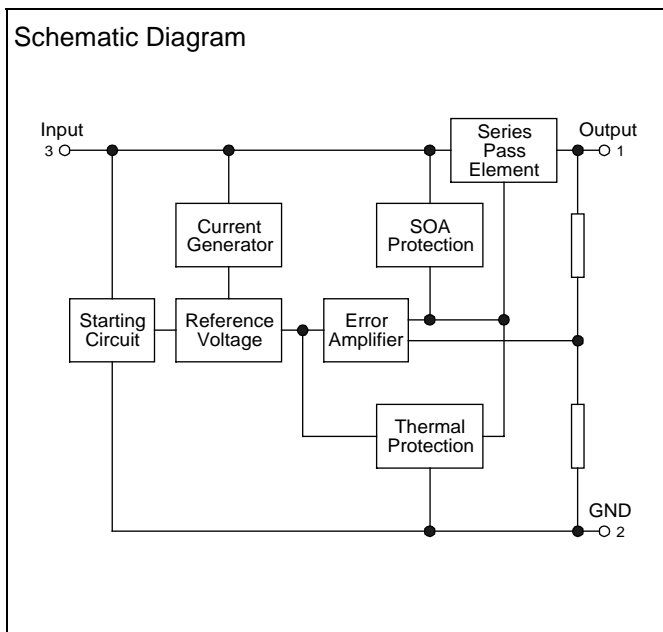

Equivalent Circuit

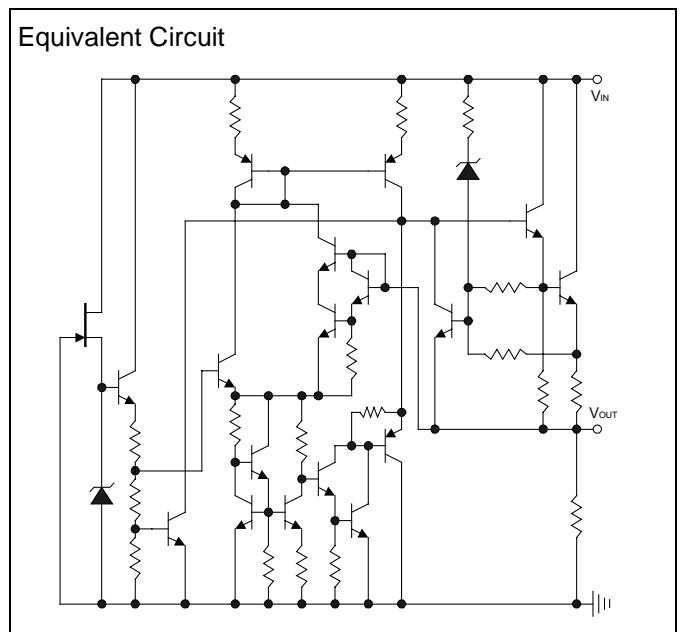



H78L05XX Electrical Characteristics

$V_{IN}=10V$, $I_{OUT}=40mA$, $C_{IN}=0.33\mu F$, $C_{OUT}=0.1\mu F$, $0^{\circ}C \leq T_j \leq 125^{\circ}C$ (unless otherwise specified)

Symbol	Parameter	Conditions	H78L05AM/AA			Units
			Min	Typ	Max	
V_O	Output Voltage	$T_j=25^{\circ}C$	4.85	5	5.15	V
		$1mA \leq I_{OUT} \leq 70mA$	4.85	5	5.15	
		$7V \leq V_{IN} \leq 20V$, $1mA \leq I_{OUT} \leq 40mA$				
Reg_{line}	Line Regulation	$T_j=25^{\circ}C$, $7V \leq V_{IN} \leq 20V$	-	15	150	mV
		$T_j=25^{\circ}C$, $8V \leq V_{IN} \leq 20V$	-	15	100	
Reg_{load}	Load Regulation	$T_j=25^{\circ}C$, $1mA \leq I_{OUT} \leq 100mA$	-	11	60	mV
		$T_j=25^{\circ}C$, $1mA \leq I_{OUT} \leq 40mA$	-	5	30	
I_B	Quiescent Current	$I_{OUT}=5mA$, $T_j=25^{\circ}C$	-	3.9	6	mA
ΔI_B	Quiescent Current Change	$8V \leq V_{IN} \leq 20V$, $T_j=25^{\circ}C$	-	-	1.5	mA
		$1mA \leq I_{OUT} \leq 40mA$, $T_j=25^{\circ}C$	-	-	0.1	
V_N	Output Noise Voltage	$10Hz \leq f \leq 100KHz$, $T_j=25^{\circ}C$	-	40	-	μV_{rms}
RR	Ripple Rejection	$8V \leq V_{IN} \leq 18V$, $f=120Hz$, $T_j=25^{\circ}C$	41	49	-	dB
V_D	Dropout Voltage	$T_j=25^{\circ}C$, $I_{OUT}=100mA$	-	1.7	2.5	V
R_O	Output Resistance	$f=1KHz$	-	17	-	$m\Omega$
I_{SC}	Short Circuit Current	$V_{IN}=10V$, $T_j=25^{\circ}C$	-	1.5	2	A
T_{CVO}	Average Temperature Coefficient of Output Voltage	$I_{OUT}=5mA$	-	-	0.6	$mV/^{\circ}C$

Symbol	Parameter	Conditions	H78L05BM/BA			Units
			Min	Typ	Max	
V_O	Output Voltage	$T_j=25^{\circ}C$	4.75	5	5.25	V
		$1mA \leq I_{OUT} \leq 70mA$	4.75	5	5.25	
		$7V \leq V_{IN} \leq 20V$, $1mA \leq I_{OUT} \leq 40mA$				
Reg_{line}	Line Regulation	$T_j=25^{\circ}C$, $7V \leq V_{IN} \leq 20V$	-	15	150	mV
		$T_j=25^{\circ}C$, $8V \leq V_{IN} \leq 20V$	-	15	100	
Reg_{load}	Load Regulation	$T_j=25^{\circ}C$, $1mA \leq I_{OUT} \leq 100mA$	-	11	60	mV
		$T_j=25^{\circ}C$, $1mA \leq I_{OUT} \leq 40mA$	-	5	30	
I_B	Quiescent Current	$I_{OUT}=5mA$, $T_j=25^{\circ}C$	-	3.9	6	mA
ΔI_B	Quiescent Current Change	$8V \leq V_{IN} \leq 20V$, $T_j=25^{\circ}C$	-	-	1.5	mA
		$1mA \leq I_{OUT} \leq 40mA$, $T_j=25^{\circ}C$	-	-	0.1	
V_N	Output Noise Voltage	$10Hz \leq f \leq 100KHz$, $T_j=25^{\circ}C$	-	40	-	μV_{rms}
RR	Ripple Rejection	$8V \leq V_{IN} \leq 18V$, $f=120Hz$, $T_j=25^{\circ}C$	41	49	-	dB
V_D	Dropout Voltage	$T_j=25^{\circ}C$, $I_{OUT}=100mA$	-	1.7	2.5	V
R_O	Output Resistance	$f=1KHz$	-	17	-	$m\Omega$
I_{SC}	Short Circuit Current	$V_{IN}=10V$, $T_j=25^{\circ}C$	-	1.5	2	A
T_{CVO}	Average Temperature Coefficient of Output Voltage	$I_{OUT}=5mA$	-	-	0.6	$mV/^{\circ}C$



H78L06XX Electrical Characteristics

$V_{IN}=11V$, $I_{OUT}=40mA$, $C_{IN}=0.33\mu F$, $C_{OUT}=0.1\mu F$, $0^{\circ}C \leq T_j \leq 125^{\circ}C$ (unless otherwise specified)

Symbol	Parameter	Conditions	H78L06AM/AA			Units
			Min	Typ	Max	
V_O	Output Voltage	$T_j=25^{\circ}C$	5.82	6	6.18	V
		$1mA \leq I_{OUT} \leq 70mA$	5.82	6	6.18	
		$8V \leq V_{IN} \leq 22V$, $1mA \leq I_{OUT} \leq 40mA$				
Reg_{line}	Line Regulation	$T_j=25^{\circ}C$, $8V \leq V_{IN} \leq 22V$	-	15	155	mV
		$T_j=25^{\circ}C$, $9V \leq V_{IN} \leq 12V$	-	20	105	
Reg_{load}	Load Regulation	$T_j=25^{\circ}C$, $1mA \leq I_{OUT} \leq 100mA$	-	15	70	mV
		$T_j=25^{\circ}C$, $1mA \leq I_{OUT} \leq 40mA$	-	5	35	
I_B	Quiescent Current	$I_{OUT}=5mA$, $T_j=25^{\circ}C$	-	3.9	6	mA
ΔI_B	Quiescent Current Change	$9V \leq V_{IN} \leq 22V$, $T_j=25^{\circ}C$	-	-	1.5	mA
		$1mA \leq I_{OUT} \leq 40mA$, $T_j=25^{\circ}C$	-	-	0.1	
V_N	Output Noise Voltage	$10Hz \leq f \leq 100KHz$, $T_j=25^{\circ}C$	-	50	-	μV_{rms}
RR	Ripple Rejection	$9V \leq V_{IN} \leq 19V$, $f=120Hz$, $T_j=25^{\circ}C$	39	47	-	dB
V_D	Dropout Voltage	$T_j=25^{\circ}C$, $I_{OUT}=100mA$	-	1.7	2.5	V
R_O	Output Resistance	$f=1KHz$	-	17	-	$m\Omega$
I_{SC}	Short Circuit Current	$V_{IN}=10V$, $T_j=25^{\circ}C$	-	1.5	2	A
T_{CVO}	Average Temperature Coefficient of Output Voltage	$I_{OUT}=5mA$	-	-	0.7	$mV/^{\circ}C$

Symbol	Parameter	Conditions	H78L06BM/BA			Units
			Min	Typ	Max	
V_O	Output Voltage	$T_j=25^{\circ}C$	5.7	6	6.3	V
		$1mA \leq I_{OUT} \leq 70mA$	5.7	6	6.3	
		$8V \leq V_{IN} \leq 22V$, $1mA \leq I_{OUT} \leq 40mA$				
Reg_{line}	Line Regulation	$T_j=25^{\circ}C$, $8V \leq V_{IN} \leq 22V$	-	15	155	mV
		$T_j=25^{\circ}C$, $9V \leq V_{IN} \leq 12V$	-	20	105	
Reg_{load}	Load Regulation	$T_j=25^{\circ}C$, $1mA \leq I_{OUT} \leq 100mA$	-	15	70	mV
		$T_j=25^{\circ}C$, $1mA \leq I_{OUT} \leq 40mA$	-	5	35	
I_B	Quiescent Current	$I_{OUT}=5mA$, $T_j=25^{\circ}C$	-	3.9	6	mA
ΔI_B	Quiescent Current Change	$9V \leq V_{IN} \leq 22V$, $T_j=25^{\circ}C$	-	-	1.5	mA
		$1mA \leq I_{OUT} \leq 40mA$, $T_j=25^{\circ}C$	-	-	0.1	
V_N	Output Noise Voltage	$10Hz \leq f \leq 100KHz$, $T_j=25^{\circ}C$	-	50	-	μV_{rms}
RR	Ripple Rejection	$9V \leq V_{IN} \leq 19V$, $f=120Hz$, $T_j=25^{\circ}C$	39	47	-	dB
V_D	Dropout Voltage	$T_j=25^{\circ}C$, $I_{OUT}=100mA$	-	1.7	2.5	V
R_O	Output Resistance	$f=1KHz$	-	17	-	$m\Omega$
I_{SC}	Short Circuit Current	$V_{IN}=10V$, $T_j=25^{\circ}C$	-	1.5	2	A
T_{CVO}	Average Temperature Coefficient of Output Voltage	$I_{OUT}=5mA$	-	-	0.7	$mV/^{\circ}C$



H78L08XX Electrical Characteristics

$V_{IN}=14V$, $I_{OUT}=40mA$, $C_{IN}=0.33\mu F$, $C_{OUT}=0.1\mu F$, $0^{\circ}C \leq T_j \leq 125^{\circ}C$ (unless otherwise specified)

Symbol	Parameter	Conditions	H78L08AM/AA			Units
			Min	Typ	Max	
V_O	Output Voltage	$T_j=25^{\circ}C$	7.76	8	8.24	V
		$1mA \leq I_{OUT} \leq 70mA$	7.76	8	8.24	
		$10.5V \leq V_{IN} \leq 23V$, $1mA \leq I_{OUT} \leq 40mA$				
Reg_{line}	Line Regulation	$T_j=25^{\circ}C$, $10.5V \leq V_{IN} \leq 23V$	-	20	175	mV
		$T_j=25^{\circ}C$, $11V \leq V_{IN} \leq 23V$	-	20	125	
Reg_{load}	Load Regulation	$T_j=25^{\circ}C$, $1mA \leq I_{OUT} \leq 100mA$	-	15	80	mV
		$T_j=25^{\circ}C$, $1mA \leq I_{OUT} \leq 40mA$	-	7	40	
I_B	Quiescent Current	$I_{OUT}=5mA$, $T_j=25^{\circ}C$	-	3.9	6	mA
ΔI_B	Quiescent Current Change	$11V \leq V_{IN} \leq 23V$, $T_j=25^{\circ}C$	-	-	1.5	mA
		$1mA \leq I_{OUT} \leq 40mA$, $T_j=25^{\circ}C$	-	-	0.1	
V_N	Output Noise Voltage	$10Hz \leq f \leq 100KHz$, $T_j=25^{\circ}C$	-	60	-	μV_{rms}
RR	Ripple Rejection	$12V \leq V_{IN} \leq 23V$, $f=120Hz$, $T_j=25^{\circ}C$	37	45	-	dB
V_D	Dropout Voltage	$T_j=25^{\circ}C$, $I_{OUT}=100mA$	-	1.7	2.5	V
R_O	Output Resistance	$f=1KHz$	-	17	-	$m\Omega$
I_{SC}	Short Circuit Current	$T_j=25^{\circ}C$	-	1.5	2	A
T_{CVO}	Average Temperature Coefficient of Output Voltage	$I_{OUT}=5mA$	-	-	0.9	$mV/^{\circ}C$

Symbol	Parameter	Conditions	H78L08BM/BA			Units
			Min	Typ	Max	
V_O	Output Voltage	$T_j=25^{\circ}C$	7.6	8	8.4	V
		$1mA \leq I_{OUT} \leq 70mA$	7.6	8	8.4	
		$10.5V \leq V_{IN} \leq 23V$, $1mA \leq I_{OUT} \leq 40mA$				
Reg_{line}	Line Regulation	$T_j=25^{\circ}C$, $10.5V \leq V_{IN} \leq 23V$	-	20	175	mV
		$T_j=25^{\circ}C$, $11V \leq V_{IN} \leq 23V$	-	20	125	
Reg_{load}	Load Regulation	$T_j=25^{\circ}C$, $1mA \leq I_{OUT} \leq 100mA$	-	15	80	mV
		$T_j=25^{\circ}C$, $1mA \leq I_{OUT} \leq 40mA$	-	7	40	
I_B	Quiescent Current	$I_{OUT}=5mA$, $T_j=25^{\circ}C$	-	3.9	6	mA
ΔI_B	Quiescent Current Change	$11V \leq V_{IN} \leq 23V$, $T_j=25^{\circ}C$	-	-	1.5	mA
		$1mA \leq I_{OUT} \leq 40mA$, $T_j=25^{\circ}C$	-	-	0.1	
V_N	Output Noise Voltage	$10Hz \leq f \leq 100KHz$, $T_j=25^{\circ}C$	-	60	-	μV_{rms}
RR	Ripple Rejection	$12V \leq V_{IN} \leq 23V$, $f=120Hz$, $T_j=25^{\circ}C$	37	45	-	dB
V_D	Dropout Voltage	$T_j=25^{\circ}C$, $I_{OUT}=100mA$	-	1.7	2.5	V
R_O	Output Resistance	$f=1KHz$	-	17	-	$m\Omega$
I_{SC}	Short Circuit Current	$T_j=25^{\circ}C$	-	1.5	2	A
T_{CVO}	Average Temperature Coefficient of Output Voltage	$I_{OUT}=5mA$	-	-	0.9	$mV/^{\circ}C$



H78L09XX Electrical Characteristics

$V_{IN}=15V$, $I_{OUT}=40mA$, $C_{IN}=0.33\mu F$, $C_{OUT}=0.1\mu F$, $0^{\circ}C \leq T_j \leq 125^{\circ}C$ (unless otherwise specified)

Symbol	Parameter	Conditions	H78L09AM/AA			Units
			Min	Typ	Max	
V_O	Output Voltage	$T_j=25^{\circ}C$	8.73	9	9.27	V
		$1mA \leq I_{OUT} \leq 70mA$	8.73	9	9.27	
		$11.4V \leq V_{IN} \leq 24V$, $1mA \leq I_{OUT} \leq 40mA$				
Reg_{line}	Line Regulation	$T_j=25^{\circ}C$, $11.4V \leq V_{IN} \leq 24V$	-	80	200	mV
		$T_j=25^{\circ}C$, $12V \leq V_{IN} \leq 24V$	-	20	160	
Reg_{load}	Load Regulation	$T_j=25^{\circ}C$, $1mA \leq I_{OUT} \leq 100mA$	-	17	90	mV
		$T_j=25^{\circ}C$, $1mA \leq I_{OUT} \leq 40mA$	-	8	45	
I_B	Quiescent Current	$I_{OUT}=5mA$, $T_j=25^{\circ}C$	-	3.9	6	mA
ΔI_B	Quiescent Current Change	$12V \leq V_{IN} \leq 24V$, $T_j=25^{\circ}C$	-	-	1.5	mA
		$1mA \leq I_{OUT} \leq 40mA$, $T_j=25^{\circ}C$	-	-	0.1	
V_N	Output Noise Voltage	$10Hz \leq f \leq 100KHz$, $T_j=25^{\circ}C$	-	65	-	μV_{rms}
RR	Ripple Rejection	$12V \leq V_{IN} \leq 24V$, $f=120Hz$, $T_j=25^{\circ}C$	36	44	-	dB
V_D	Dropout Voltage	$T_j=25^{\circ}C$, $I_{OUT}=100mA$	-	1.7	2.5	V
R_O	Output Resistance	$f=1KHz$	-	17	-	$m\Omega$
I_{SC}	Short Circuit Current	$T_j=25^{\circ}C$	-	1.5	2	A
T_{CVO}	Average Temperature Coefficient of Output Voltage	$I_{OUT}=5mA$	-	-	1	$mV/^{\circ}C$

Symbol	Parameter	Conditions	H78L09BM/BA			Units
			Min	Typ	Max	
V_O	Output Voltage	$T_j=25^{\circ}C$	8.55	9	9.45	V
		$1mA \leq I_{OUT} \leq 70mA$	8.55	9	9.45	
		$11.4V \leq V_{IN} \leq 24V$, $1mA \leq I_{OUT} \leq 40mA$				
Reg_{line}	Line Regulation	$T_j=25^{\circ}C$, $11.4V \leq V_{IN} \leq 24V$	-	80	200	mV
		$T_j=25^{\circ}C$, $12V \leq V_{IN} \leq 24V$	-	20	160	
Reg_{load}	Load Regulation	$T_j=25^{\circ}C$, $1mA \leq I_{OUT} \leq 100mA$	-	17	90	mV
		$T_j=25^{\circ}C$, $1mA \leq I_{OUT} \leq 40mA$	-	8	45	
I_B	Quiescent Current	$I_{OUT}=5mA$, $T_j=25^{\circ}C$	-	3.9	6	mA
ΔI_B	Quiescent Current Change	$12V \leq V_{IN} \leq 24V$, $T_j=25^{\circ}C$	-	-	1.5	mA
		$1mA \leq I_{OUT} \leq 40mA$, $T_j=25^{\circ}C$	-	-	0.1	
V_N	Output Noise Voltage	$10Hz \leq f \leq 100KHz$, $T_j=25^{\circ}C$	-	65	-	μV_{rms}
RR	Ripple Rejection	$12V \leq V_{IN} \leq 24V$, $f=120Hz$, $T_j=25^{\circ}C$	36	44	-	dB
V_D	Dropout Voltage	$T_j=25^{\circ}C$, $I_{OUT}=100mA$	-	1.7	2.5	V
R_O	Output Resistance	$f=1KHz$	-	17	-	$m\Omega$
I_{SC}	Short Circuit Current	$T_j=25^{\circ}C$	-	1.5	2	A
T_{CVO}	Average Temperature Coefficient of Output Voltage	$I_{OUT}=5mA$	-	-	1	$mV/^{\circ}C$



H78L12XX Electrical Characteristics

$V_{IN}=19V$, $I_{OUT}=40mA$, $C_{IN}=0.33\mu F$, $C_{OUT}=0.1\mu F$, $0^{\circ}C \leq T_j \leq 125^{\circ}C$ (unless otherwise specified)

Symbol	Parameter	Conditions	H78L12AM/AA			Units
			Min	Typ	Max	
V_O	Output Voltage	$T_j=25^{\circ}C$	11.64	12	12.36	V
		$1mA \leq I_{OUT} \leq 70mA$	11.64	12	12.36	
		$14.5V \leq V_{IN} \leq 27V$, $1mA \leq I_{OUT} \leq 40mA$				
Reg_{line}	Line Regulation	$T_j=25^{\circ}C$, $14.5V \leq V_{IN} \leq 27V$	-	120	250	mV
		$T_j=25^{\circ}C$, $16V \leq V_{IN} \leq 27V$	-	100	200	
Reg_{load}	Load Regulation	$T_j=25^{\circ}C$, $1mA \leq I_{OUT} \leq 100mA$	-	20	100	mV
		$T_j=25^{\circ}C$, $1mA \leq I_{OUT} \leq 40mA$	-	10	50	
I_B	Quiescent Current	$I_{OUT}=5mA$, $T_j=25^{\circ}C$	-	3.9	6	mA
ΔI_B	Quiescent Current Change	$16V \leq V_{IN} \leq 27V$, $T_j=25^{\circ}C$	-	-	1.5	mA
		$1mA \leq I_{OUT} \leq 40mA$, $T_j=25^{\circ}C$	-	-	0.1	
V_N	Output Noise Voltage	$10Hz \leq f \leq 100KHz$, $T_j=25^{\circ}C$	-	80	-	μV_{rms}
RR	Ripple Rejection	$15V \leq V_{IN} \leq 25V$, $f=120Hz$, $T_j=25^{\circ}C$	36	41	-	dB
V_D	Dropout Voltage	$T_j=25^{\circ}C$, $I_{OUT}=100mA$	-	1.7	2.5	V
R_O	Output Resistance	$f=1KHz$	-	17	-	$m\Omega$
I_{SC}	Short Circuit Current	$T_j=25^{\circ}C$	-	1.5	2	A
T_{CVO}	Average Temperature Coefficient of Output Voltage	$I_{OUT}=5mA$	-	-	1.4	$mV/^{\circ}C$

Symbol	Parameter	Conditions	H78L12BM/BA			Units
			Min	Typ	Max	
V_O	Output Voltage	$T_j=25^{\circ}C$	11.4	12	12.6	V
		$1mA \leq I_{OUT} \leq 70mA$	11.4	12	12.6	
		$14.5V \leq V_{IN} \leq 27V$, $1mA \leq I_{OUT} \leq 40mA$				
Reg_{line}	Line Regulation	$T_j=25^{\circ}C$, $14.5V \leq V_{IN} \leq 27V$	-	120	250	mV
		$T_j=25^{\circ}C$, $16V \leq V_{IN} \leq 27V$	-	100	200	
Reg_{load}	Load Regulation	$T_j=25^{\circ}C$, $1mA \leq I_{OUT} \leq 100mA$	-	20	100	mV
		$T_j=25^{\circ}C$, $1mA \leq I_{OUT} \leq 40mA$	-	10	50	
I_B	Quiescent Current	$I_{OUT}=5mA$, $T_j=25^{\circ}C$	-	3.9	6	mA
ΔI_B	Quiescent Current Change	$16V \leq V_{IN} \leq 27V$, $T_j=25^{\circ}C$	-	-	1.5	mA
		$1mA \leq I_{OUT} \leq 40mA$, $T_j=25^{\circ}C$	-	-	0.1	
V_N	Output Noise Voltage	$10Hz \leq f \leq 100KHz$, $T_j=25^{\circ}C$	-	80	-	μV_{rms}
RR	Ripple Rejection	$15V \leq V_{IN} \leq 25V$, $f=120Hz$, $T_j=25^{\circ}C$	36	41	-	dB
V_D	Dropout Voltage	$T_j=25^{\circ}C$, $I_{OUT}=100mA$	-	1.7	2.5	V
R_O	Output Resistance	$f=1KHz$	-	17	-	$m\Omega$
I_{SC}	Short Circuit Current	$T_j=25^{\circ}C$	-	1.5	2	A
T_{CVO}	Average Temperature Coefficient of Output Voltage	$I_{OUT}=5mA$	-	-	1.4	$mV/^{\circ}C$



Test Circuits

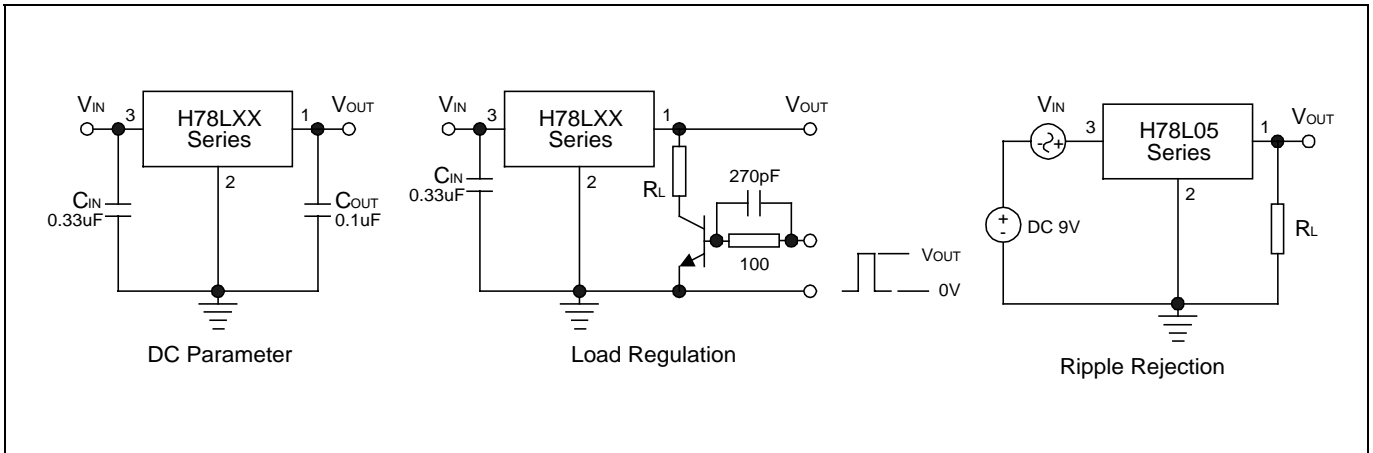

Application Circuits

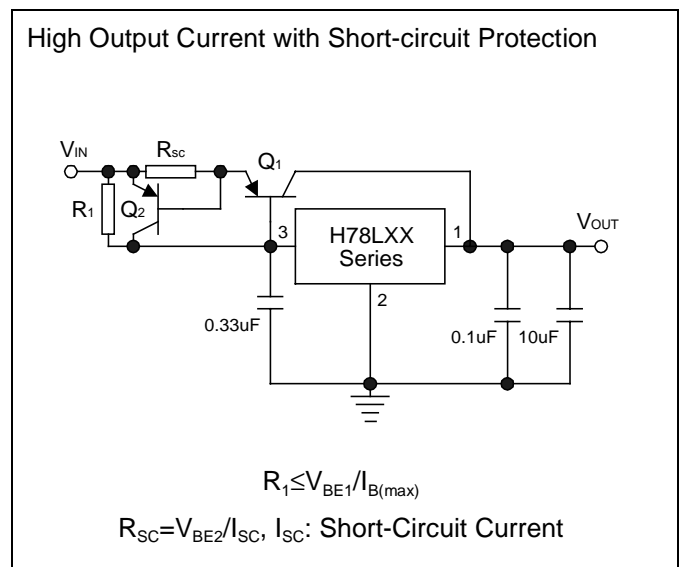
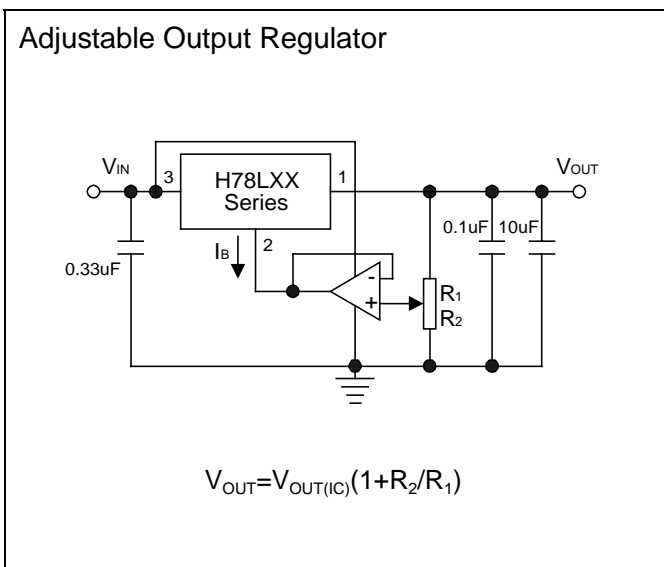
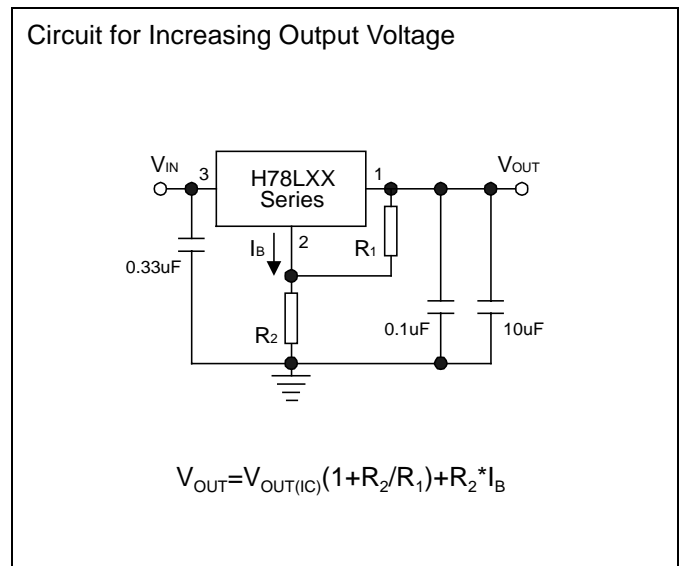
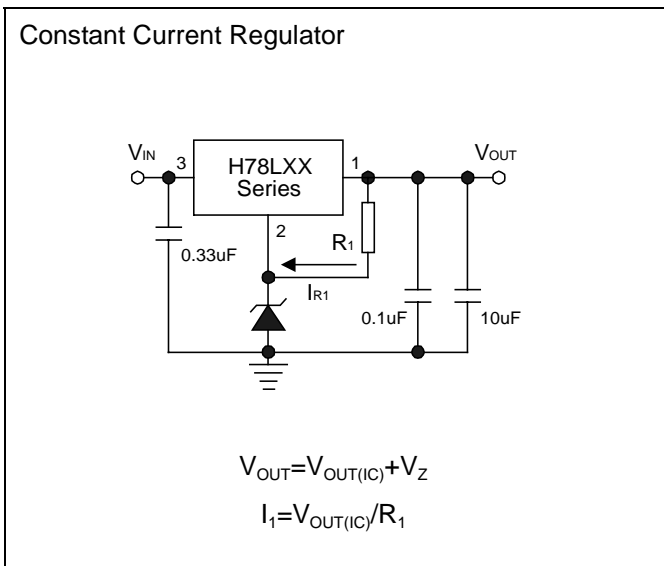



Characteristics Curve

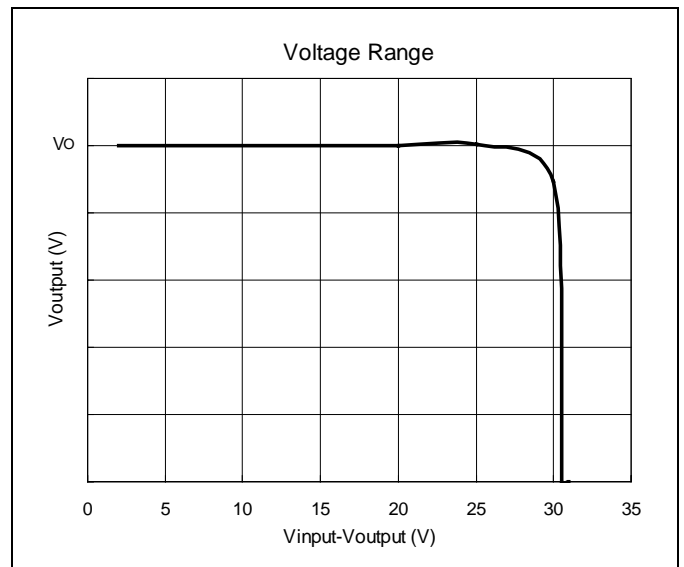
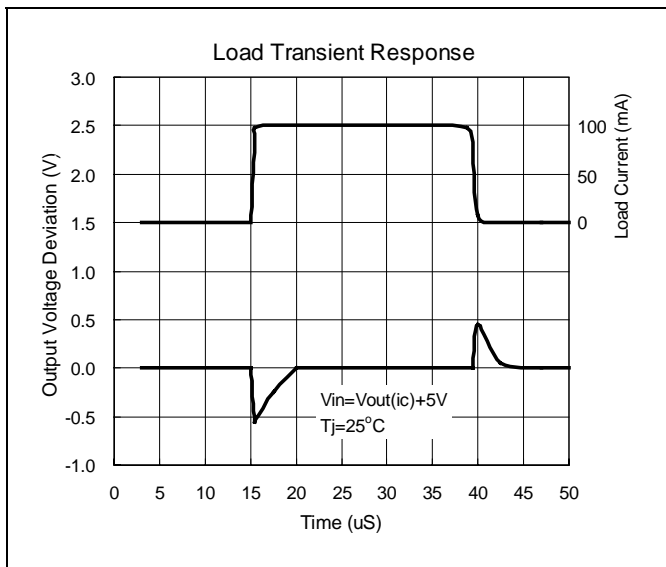
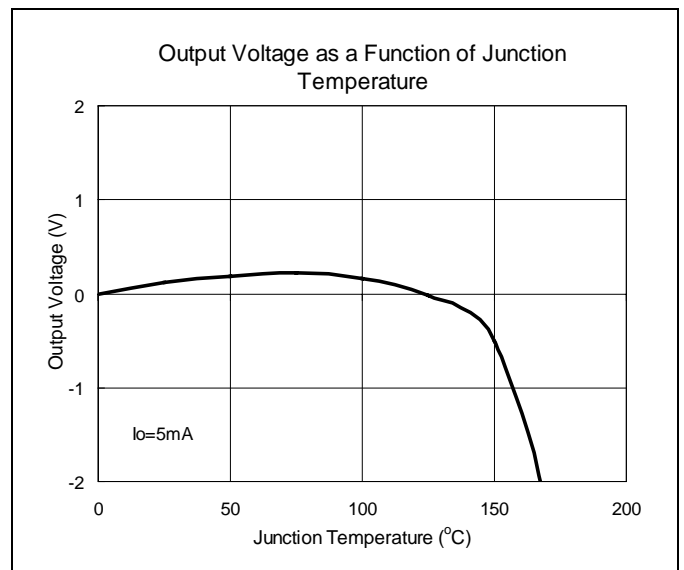
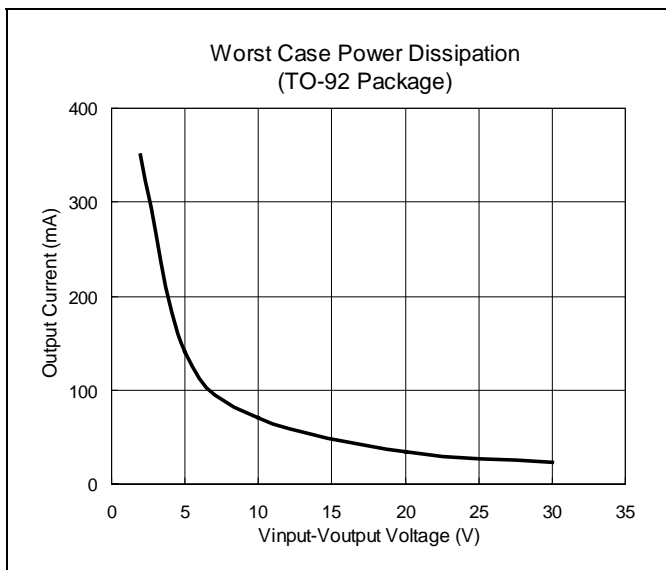
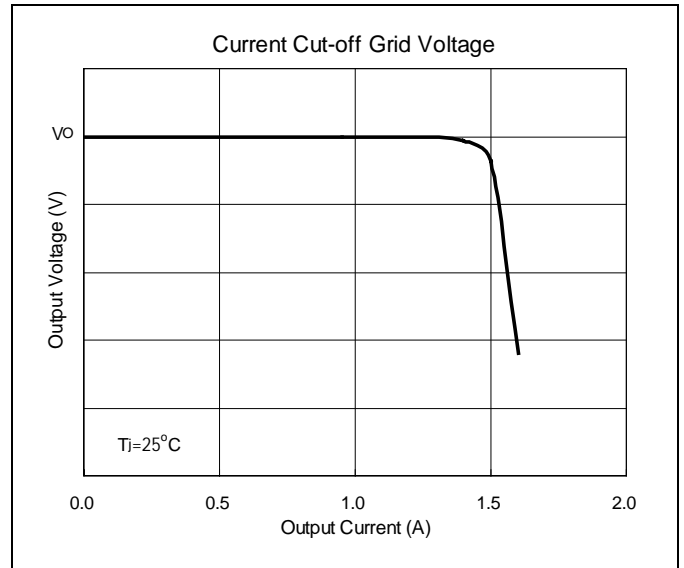
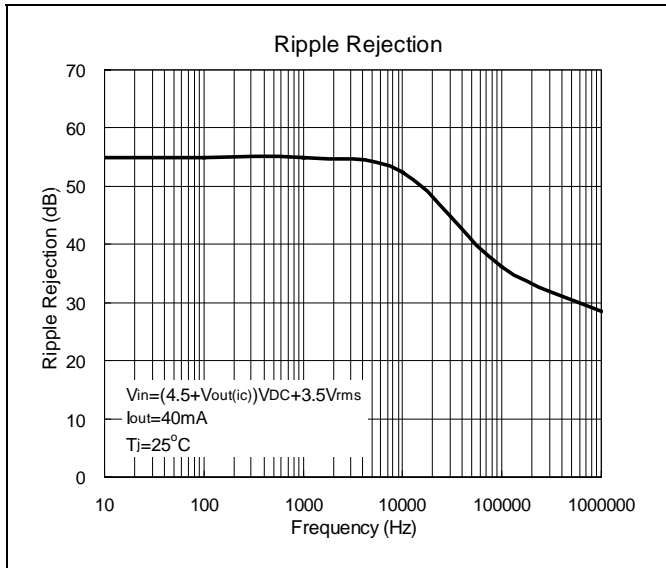



TO-92 Dimension

3-Lead TO-92 Plastic Package
HSMC Package Code: A

Marking:

Pb Free Mark
 Pb-Free: "●" (Note)
 Normal: None

Product Series (05,06,08,09,12)

Date Code

Control Code

Note: Green label is used for pb-free packing

Pin Style: 1.Output 2.Ground 3.Input

Material:

- Lead solder plating: Sn60/Pb40 (Normal), Sn/3.0Ag/0.5Cu or Pure-Tin (Pb-free)
- Mold Compound: Epoxy resin family, flammability solid burning class: UL94V-0

DIM	Min.	Max.
A	4.33	4.83
B	4.33	4.83
C	12.70	-
D	0.36	0.56
E	-	*1.27
F	3.36	3.76
G	0.36	0.56
H	-	*2.54
I	-	*1.27
α1	-	*5°
α2	-	*2°
α3	-	*2°

*: Typical, Unit: mm

SOT-89 Dimension

3-Lead SOT-89 Plastic
Surface Mounted Package
HSMC Package Code: M

Marking:

Date Code

Control Code

Pb Free Mark
 Pb-Free: "●" (Note)
 Normal: None

Product Series (05,06,08,09,12)

Note: Green label is used for pb-free packing

Pin Style: 1.Output 2.Ground 3.Input

Material:

- Lead solder plating: Sn60/Pb40 (Normal), Sn/3.0Ag/0.5Cu or Pure-Tin (Pb-free)
- Mold Compound: Epoxy resin family, flammability solid burning class: UL94V-0

DIM	Min.	Max.
A	4.40	4.60
B	4.05	4.25
C	1.50	1.70
D	2.40	2.60
E	0.36	0.51
F	*1.50	-
G	*3.00	-
H	1.40	1.60
I	0.35	0.41

*: Typical, Unit: mm

Important Notice:

- All rights are reserved. Reproduction in whole or in part is prohibited without the prior written approval of HSMC.
- HSMC reserves the right to make changes to its products without notice.
- **HSMC semiconductor products are not warranted to be suitable for use in Life-Support Applications, or systems.**
- HSMC assumes no liability for any consequence of customer product design, infringement of patents, or application assistance.

Head Office And Factory:

- **Head Office** (Hi-Sincerity Microelectronics Corp.): 10F.,No. 61, Sec. 2, Chung-Shan N. Rd. Taipei Taiwan R.O.C.
Tel: 886-2-25212056 Fax: 886-2-25632712, 25368454
- **Factory 1:** No. 38, Kuang Fu S. Rd., Fu-Kou Hsin-Chu Industrial Park Hsin-Chu Taiwan. R.O.C
Tel: 886-3-5983621~5 Fax: 886-3-5982931



Soldering Methods for HSMC's Products

1. Storage environment: Temperature=10°C~35°C Humidity=65%±15%
2. Reflow soldering of surface-mount devices

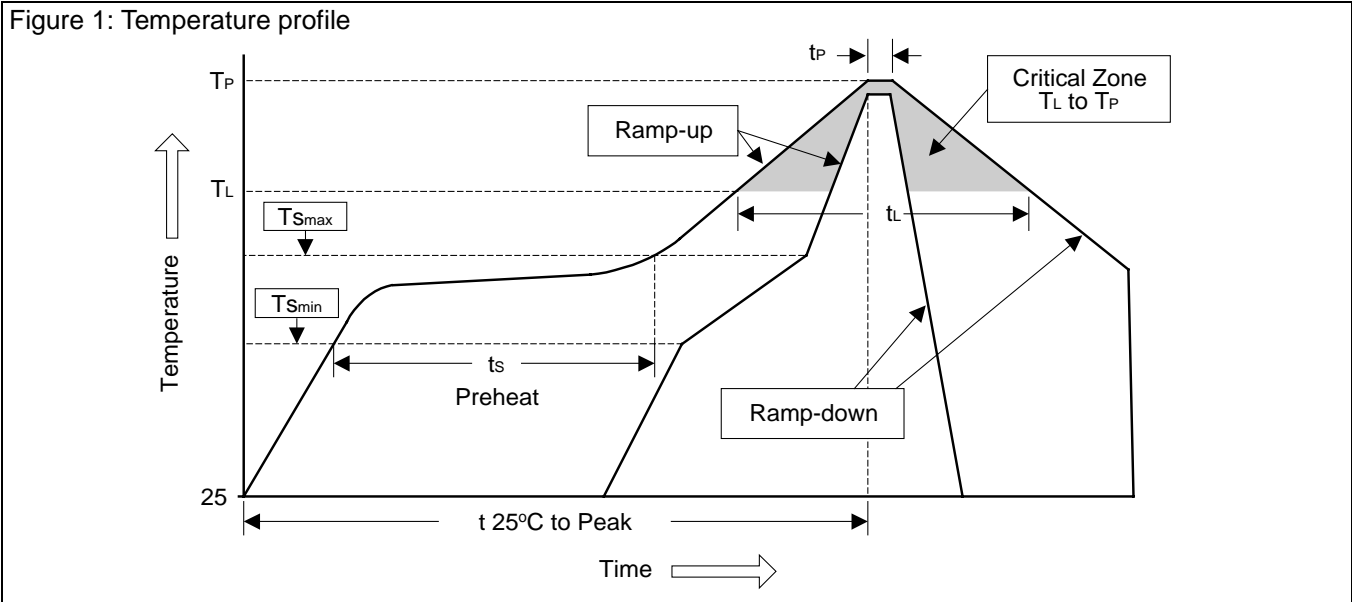

Profile Feature	Sn-Pb Eutectic Assembly	Pb-Free Assembly
Average ramp-up rate (T_L to T_P)	$<3^\circ\text{C}/\text{sec}$	$<3^\circ\text{C}/\text{sec}$
Preheat		
- Temperature Min (T_{Smin})	100°C	150°C
- Temperature Max (T_{Smax})	150°C	200°C
- Time (min to max) (t_s)	60~120 sec	60~180 sec
T_{Smax} to T_L		
- Ramp-up Rate	$<3^\circ\text{C}/\text{sec}$	$<3^\circ\text{C}/\text{sec}$
Time maintained above:		
- Temperature (T_L)	183°C	217°C
- Time (t_L)	60~150 sec	60~150 sec
Peak Temperature (T_P)	240°C +0/-5°C	260°C +0/-5°C
Time within 5°C of actual Peak Temperature (t_P)	10~30 sec	20~40 sec
Ramp-down Rate	$<6^\circ\text{C}/\text{sec}$	$<6^\circ\text{C}/\text{sec}$
Time 25°C to Peak Temperature	<6 minutes	<8 minutes

3. Flow (wave) soldering (solder dipping)

Products	Peak temperature	Dipping time
Pb devices.	245°C ±5°C	5sec ±1sec
Pb-Free devices.	260°C +0/-5°C	5sec ±1sec