

ABSOLUTE MAXIMUM RATINGS

(Note 1)

Input Voltage (V_{IN}).....	40V
BOOST Pin Voltage	50V
BOOST Pin Above SW Pin.....	25V
SHDN Pin.....	40V
FB Pin	6V
V_C Pin	3V
R_T Pin	3V
Operating Temperature Range (Note 2)	
LT3505E	-40°C to 85°C
LT3505I	-40°C to 125°C
Maximum Junction Temperature	125°C
Storage Temperature Range.....	-65°C to 150°C

PACKAGE/ORDER INFORMATION

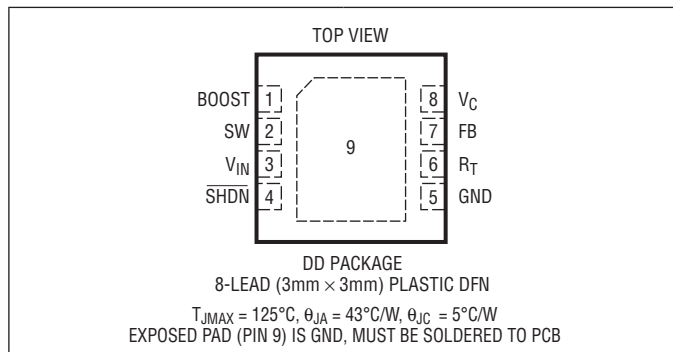

ORDER PART NUMBER	DD PART MARKING
LT3505EDD	LCHB
LT3505IDD	LCHC

Order Options Tape and Reel: Add #TR
 Lead Free: Add #PBF Lead Free Tape and Reel: Add #TRPBF
 Lead Free Part Marking: <http://www.linear.com/leadfree/>

Consult LTC Marketing for parts specified with wider operating temperature ranges.

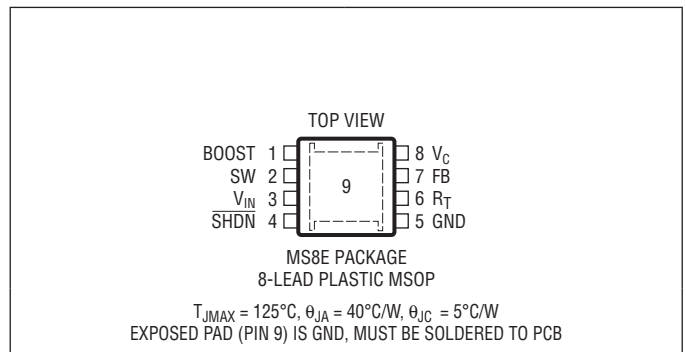

ORDER PART NUMBER	MS8E PART MARKING
LT3505EMS8E	LTCNX
LT3505IMS8E	LTCNY

Order Options Tape and Reel: Add #TR
 Lead Free: Add #PBF Lead Free Tape and Reel: Add #TRPBF
 Lead Free Part Marking: <http://www.linear.com/leadfree/>

Consult LTC Marketing for parts specified with wider operating temperature ranges.

ELECTRICAL CHARACTERISTICS

The ● denotes the specifications which apply over the full operating temperature range, otherwise specifications are at $T_A = 25^\circ\text{C}$, $V_{IN} = 12\text{V}$, $V_{BOOST} = 17\text{V}$, unless otherwise noted. (Note 2).

PARAMETER	CONDITIONS	MIN	TYP	MAX	UNITS
V_{IN} Operating Range		3.6		36	V
Undervoltage Lockout		3.1	3.35	3.6	V
Feedback Voltage		● 765	780	795	mV
FB Pin Bias Current	$V_{FB} = \text{Measured } V_{REF}$ (Note 4)		● 55	150	nA
Quiescent Current	Not Switching, $R_T = 75.0\text{k}$		2.0	2.7	mA
Quiescent Current in Shutdown	$V_{\overline{\text{SHDN}}} = 0\text{V}$		0.01	2	μA
Reference Line Regulation	$V_{IN} = 5\text{V to } 36\text{V}$		0.007		%/V
Switching Frequency	$V_{FB} = 0.7\text{V}$, $R_T = 13.7\text{k}$	2.70	3.01	3.30	MHz
	$V_{FB} = 0.7\text{V}$, $R_T = 75.0\text{k}$	675	750	825	kHz
	$V_{FB} = 0.7\text{V}$, $R_T = 357\text{k}$	180	200	220	kHz
Maximum Duty Cycle	$R_T = 75.0\text{k}$	● 90	94		%
Error Amp Transconductance	$V_{FB} = 0.78\text{V}$		200		$\mu\text{A/V}$
Error Amp Voltage Gain	$V_{FB} = 0.78\text{V}$		400		V/V
V_C Source Current	$V_{FB} = 0\text{V}$, $V_C = 1.5\text{V}$		10		μA
V_C Sink Current	$V_{FB} = 1\text{V}$, $V_C = 1.5\text{V}$		14		μA
V_C Switching Threshold Voltage	$I_{OUT} = 0\text{mA}$		0.9		V
V_C Clamp Voltage	$V_{FB} = 0\text{V}$		1.7		V
R_T Bias Voltage	$V_{FB} = 0.6\text{V}$		0.5		V
	$V_{FB} = 0\text{V}$, $R_T = 75.0\text{k}$		50		mV
Switch Current Limit	(Note 3)	1.4	1.75	2.2	A
Switch V_{CESAT}	$I_{SW} = 1\text{A}$		350		mV
Switch Leakage Current			0.1	2	μA
Minimum Boost Voltage Above Switch	$I_{SW} = 1\text{A}$		1.6	2.2	V
BOOST Pin Current	$I_{SW} = 1\text{A}$		24	50	mA
$\overline{\text{SHDN}}$ Input Voltage High		2.3			V
$\overline{\text{SHDN}}$ Input Voltage Low				0.3	V
$\overline{\text{SHDN}}$ Bias Current	$V_{\overline{\text{SHDN}}} = 2.3\text{V}$ (Note 5)		6	20	μA
	$V_{\overline{\text{SHDN}}} = 0\text{V}$		0.01	0.1	μA

Note 1: Stresses beyond those listed under Absolute Maximum Ratings may cause permanent damage to the device. Exposure to any Absolute Maximum Rating condition for extended periods may affect device reliability and lifetime.

Note 2: The LT3505E is guaranteed to meet performance specifications from 0°C to 85°C . Specifications over the -40°C to 85°C operating temperature range are assured by design, characterization and correlation with statistical process controls. The LT3505I specifications are guaranteed over the -40°C to 125°C temperature range.

Note 3: Current limit guaranteed by design and/or correlation to static test. Slope compensation reduces current limit at higher duty cycle.

Note 4: Current flows out of pin.

Note 5: Current flows into pin.

TYPICAL PERFORMANCE CHARACTERISTICS

Efficiency ($V_{OUT} = 5V$, $L = 10\mu H$, $f_{SW} = 750kHz$)

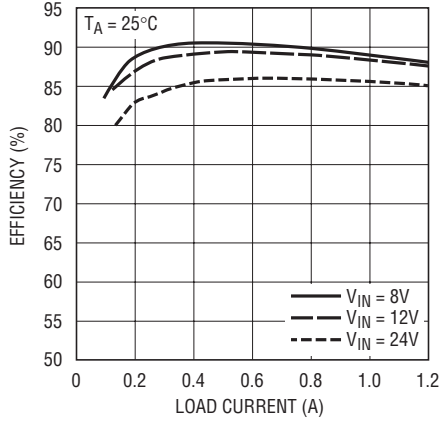

3505 G01

Efficiency ($V_{OUT} = 3.3V$, $L = 10\mu H$, $f_{SW} = 750kHz$)

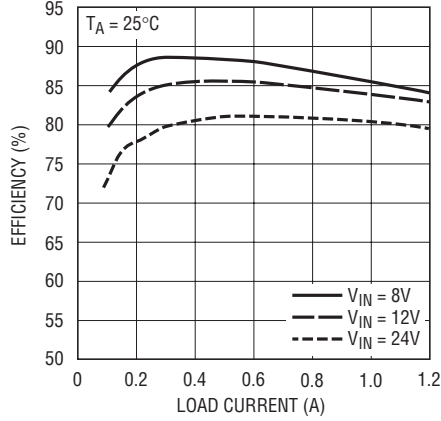

3505 G02

Efficiency ($V_{OUT} = 3.3V$, $L = 4.7\mu H$, $f_{SW} = 2.2MHz$)

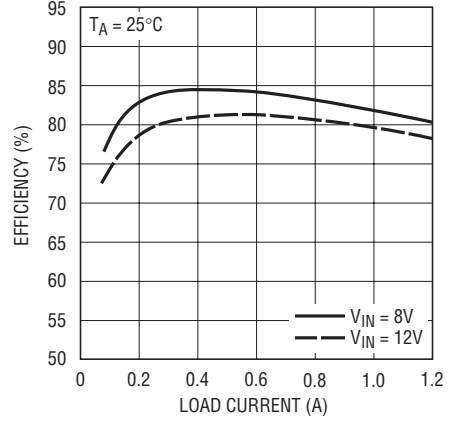

3505 G03

Efficiency ($V_{OUT} = 5V$, $L = 4.7\mu H$, $f_{SW} = 2.2MHz$)

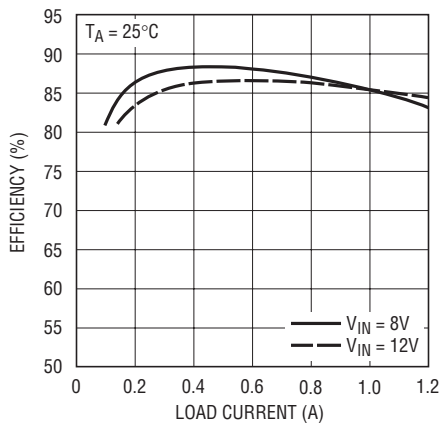

3505 G04

Max Load Current ($V_{OUT} = 3.3V$, $L = 6.8\mu H$, $f_{SW} = 750kHz$)

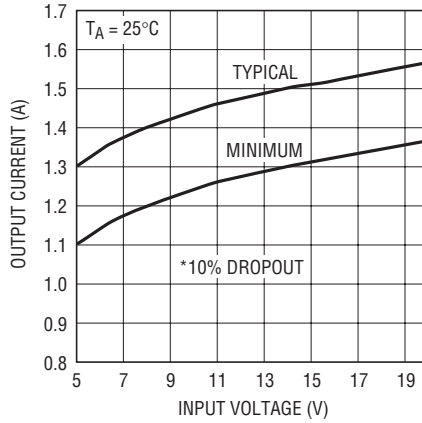

3505 G05

Max Load Current ($V_{OUT} = 5V$, $f_{SW} = 750kHz$)

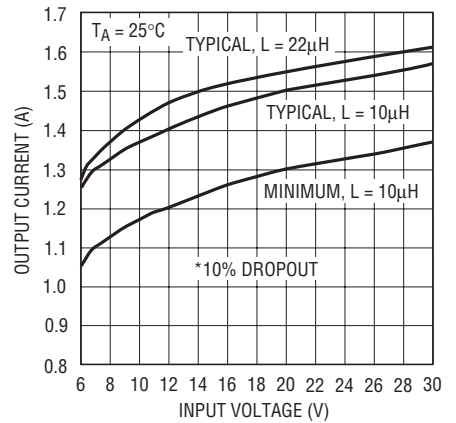

3505 G06

Max Load Current ($V_{OUT} = 3.3V$, $L = 2.2\mu H$, $f_{SW} = 2.2MHz$)

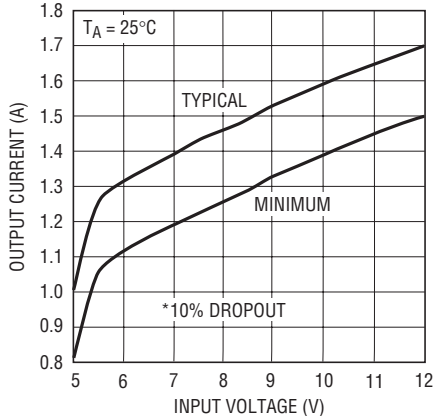

3505 G07

Max Load Current ($V_{OUT} = 5V$, $L = 3.3\mu H$, $f_{SW} = 2.2MHz$)

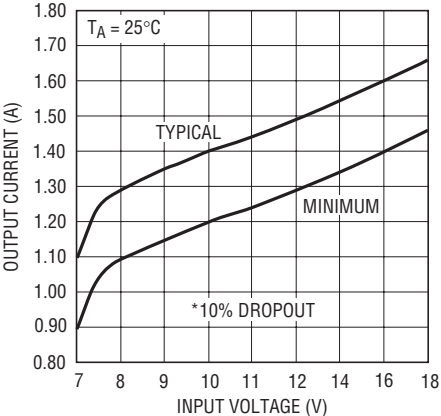

3505 G08

Switch Voltage Drop

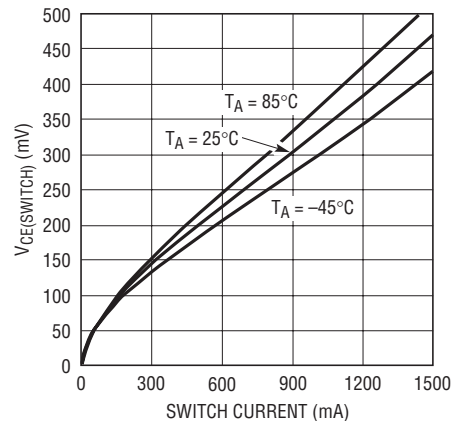

3505 G09

3505fa

TYPICAL PERFORMANCE CHARACTERISTICS

Undervoltage Lockout

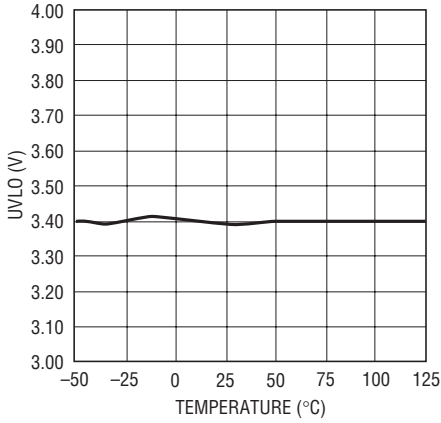

3505 G10

Switching Frequency

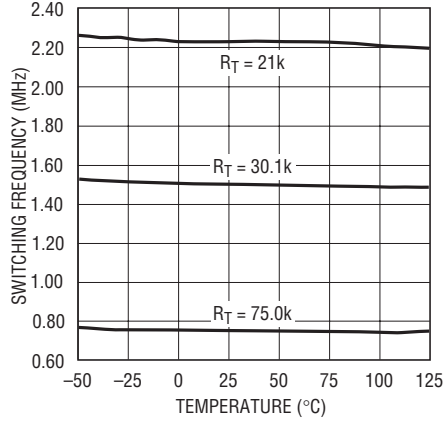

3505 G11

Frequency Foldback, $R_T = 75.0k$

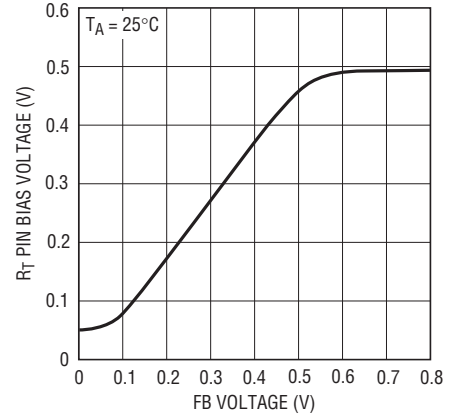

3505 G12

Soft-Start

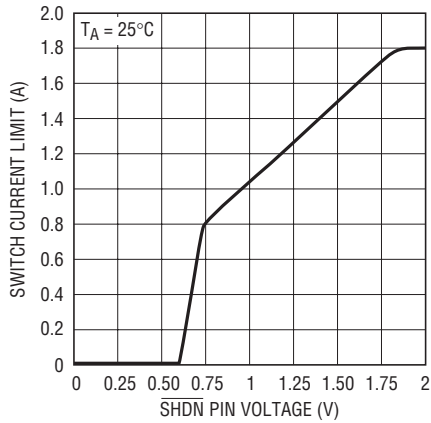

3505 G13

SHDN Pin Current

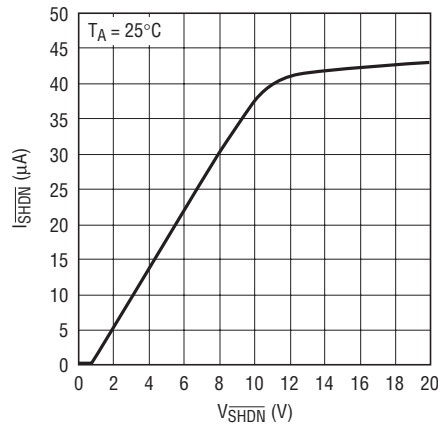

3505 G14

Typical Minimum Input Voltage, ($V_{OUT} = 5V, f_{sw} = 750kHz$)

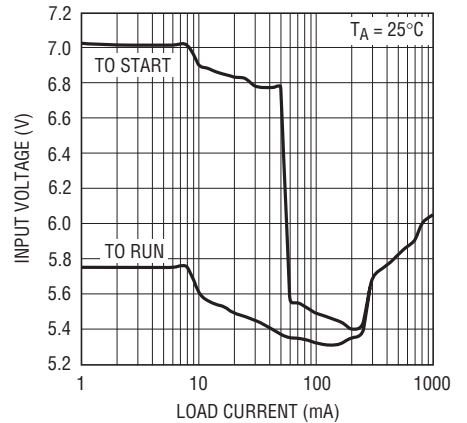

3505 G15

Typical Minimum Input Voltage, ($V_{OUT} = 3.3V, f_{sw} = 750kHz$)

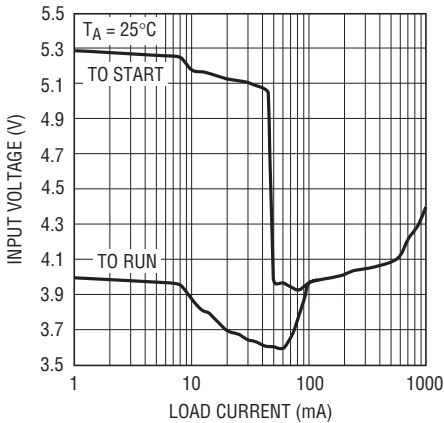

3505 G16

Typical Minimum Input Voltage, ($V_{OUT} = 3.3V, f_{sw} = 2.2MHz$)

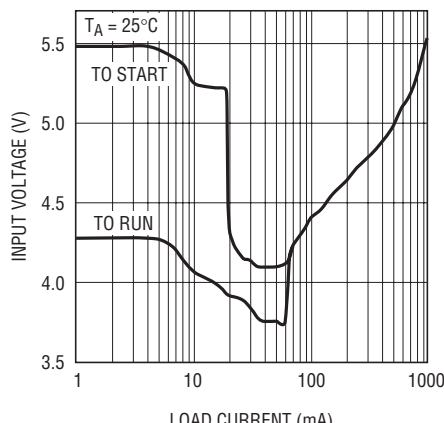

3505 G17

Typical Minimum Input Voltage, ($V_{OUT} = 5V, f_{sw} = 2.2MHz$)

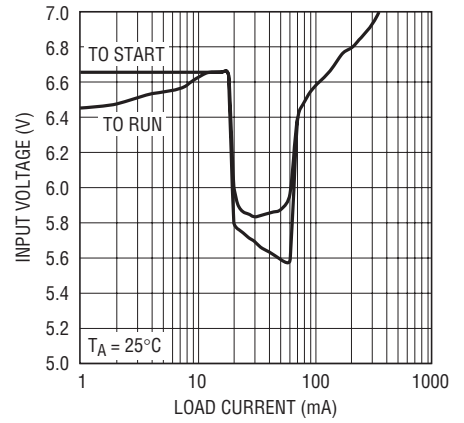

3505 G18

TYPICAL PERFORMANCE CHARACTERISTICS

Switch Current Limit

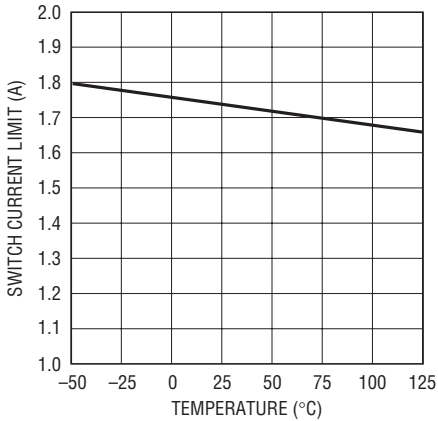

3505 G19

Switch Current Limit, $R_T = 75.0k$

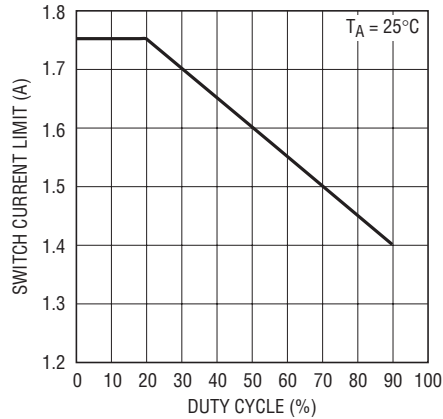

3505 G20

Typical Minimum On Time

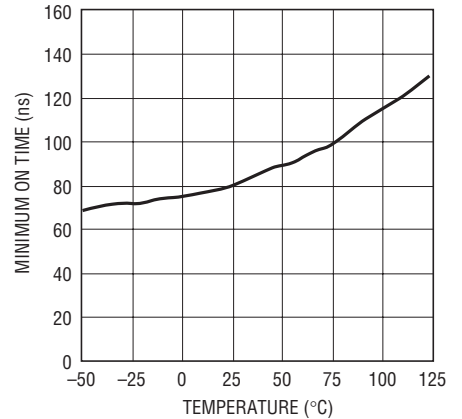

3505 G21

R_T Pin Bias Voltage

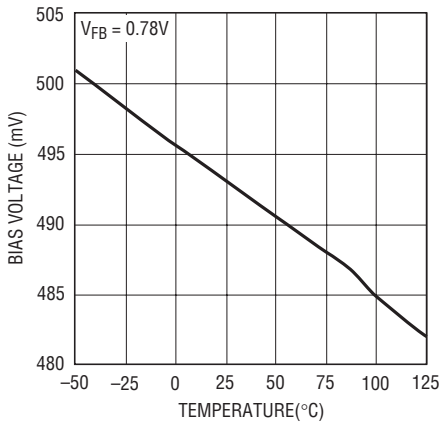

3505 G22

Switching Frequency

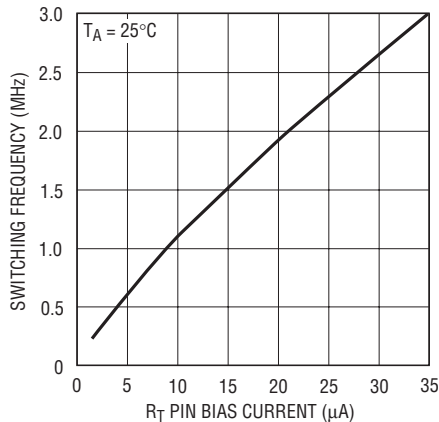

3505 G23

Switching Frequency

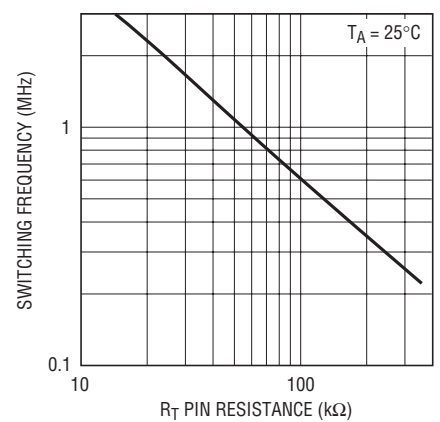

3505 G24

Operating Waveforms

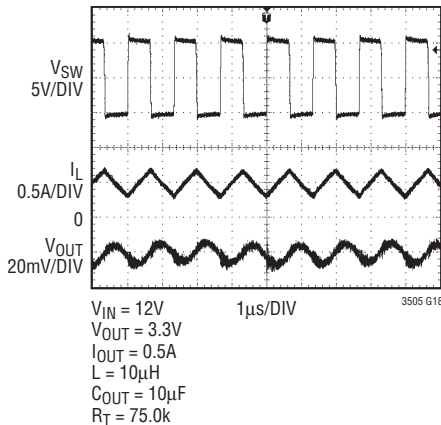

3505 G18

Operating Waveforms, Discontinuous Mode

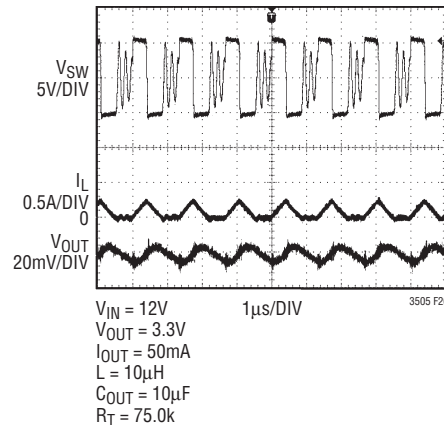

3505 F26

PIN FUNCTIONS

BOOST (Pin 1): The BOOST pin is used to provide a drive voltage, higher than the input voltage, to the internal bipolar NPN power switch.

SW (Pin 2): The SW pin is the output of the internal power switch. Connect this pin to the inductor, catch diode and boost capacitor.

V_{IN} (Pin 3): The V_{IN} pin supplies current to the LT3505's internal regulator and to the internal power switch. This pin must be locally bypassed.

SHDN (Pin 4): The SHDN pin is used to put the LT3505 in shutdown mode. Tie to ground to shut down the LT3505. Tie to 2.3V or more for normal operation. If the shutdown feature is not used, tie this pin to the V_{IN} pin. SHDN also provides a soft-start function; see the Applications Information section.

GND (Pin 5): Tie the GND pin to a local ground plane below the LT3505 and the circuit components. Return the feedback divider to this pin.

R_T (Pin 6): The R_T pin is used to program the switching frequency of the LT3505 by connecting a resistor from this pin to ground. The Applications Information section of the data sheet includes a table to determine the resistance value based on the desired switching frequency. Minimize capacitance at this pin.

FB (Pin 7): The LT3505 regulates its feedback pin to 780mV. Connect the feedback resistor divider tap to this pin. Set the output voltage by selecting R1 according to:

$$R1 = R2 \left(\frac{V_{OUT}}{0.78V} - 1 \right)$$

A good value for R2 is 10.0k.

V_C (Pin 8): The V_C pin is used to compensate the LT3505 control loop by tying an external RC network from this pin to ground.

Exposed Pad (Pin 9): The Exposed Pad must be soldered to the PCB and electrically connected to ground. Use a large ground plane and thermal vias to optimize thermal performance.

BLOCK DIAGRAM

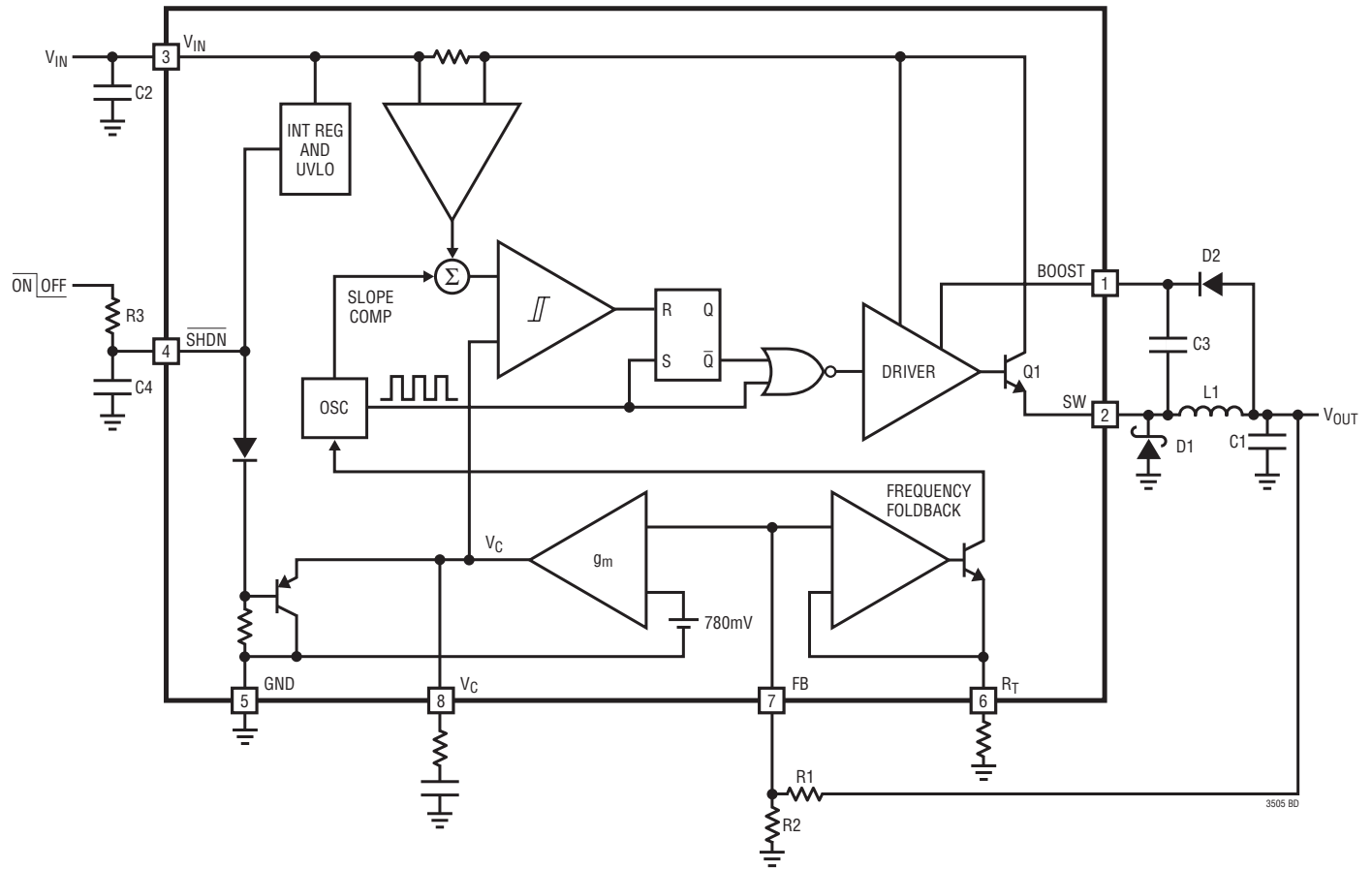

OPERATION (Refer to Block Diagram)

The LT3505 is a constant frequency, current mode step-down regulator. A resistor-programmed oscillator enables an RS flip-flop, turning on the internal 1.4A power switch Q1. An amplifier and comparator monitor the current flowing between the V_{IN} and SW pins, turning the switch off when this current reaches a level determined by the voltage at the V_C pin. An error amplifier measures the output voltage through an external resistor divider tied to the FB pin and serves the V_C node. If the error amplifier's output increases, more current is delivered to the output; if it decreases, less current is delivered. An active clamp (not shown) on the V_C node provides current limit. The V_C node is also clamped to the voltage on the \overline{SHDN} pin; soft-start is implemented by generating a voltage ramp at the \overline{SHDN} pin using an external resistor and capacitor.

An internal regulator provides power to the control circuitry. This regulator includes an undervoltage lockout to prevent switching when V_{IN} is less than ~3.4V. The \overline{SHDN} pin is used to place the LT3505 in shutdown, disconnecting the output and reducing the input current to less than 2 μ A.

The switch driver operates from either the input or from the BOOST pin. An external capacitor and diode are used to generate a voltage at the BOOST pin that is higher than the input supply. This allows the driver to fully saturate the internal bipolar NPN power switch for efficient operation.

When the FB pin is low, the voltage at the R_T pin decreases to reduce the oscillator frequency. This frequency foldback helps to control the output current during start-up and overload.

APPLICATIONS INFORMATION

FB Resistor Network

The output voltage is programmed with a resistor divider between the output and the FB pin. Choose the 1% resistors according to:

$$R1 = R2 \left(\frac{V_{OUT}}{0.78V} - 1 \right)$$

R2 should be 20k or less to avoid bias current errors. Reference designators refer to the Block Diagram.

Input Voltage Range

The input voltage range for LT3505 applications depends on the output voltage, on the absolute maximum ratings of the V_{IN} and BOOST pins, and on the programmed switching frequency.

The minimum input voltage is determined by either the LT3505's minimum operating voltage of 3.6V, or by its maximum duty cycle. The duty cycle is the fraction of time that the internal switch is on and is determined by the input and output voltages:

$$DC = \frac{V_{OUT} + V_D}{V_{IN} - V_{SW} + V_D}$$

where V_D is the forward voltage drop of the catch diode (~0.4V) and V_{SW} is the voltage drop of the internal switch (~0.4V at maximum load). This leads to a minimum input voltage of:

$$V_{IN(MIN)} = \frac{V_{OUT} + V_D}{DC_{MAX}} - V_D + V_{SW}$$

with $DC_{MAX} = 1 - f_{SW}/8.33$, where f_{SW} is in MHz.

The maximum input voltage is determined by the absolute maximum ratings of the V_{IN} and BOOST pins. For continuous mode operation, the maximum input voltage is determined by the minimum duty cycle:

$$V_{IN(PS)} = \frac{V_{OUT} + V_D}{DC_{MIN}} - V_D + V_{SW}$$

with $DC_{MIN} = f_{SW} \cdot t_{ON(MIN)}$

where f_{SW} is the switching frequency in hertz and $t_{ON(MIN)}$ is the worst-case minimum on-time in seconds. The

minimum on-time of the LT3505 is a strong function of temperature and a weak function of output current. The Typical Performance Characteristics section of the datasheet contains graphs of minimum on-time versus temperature to help determine the worst-case minimum on-time for the intended application.

Note that this is a restriction on the operating input voltage for continuous mode operation; the circuit will tolerate transient inputs up to the absolute maximum ratings of the V_{IN} and BOOST pins. The input voltage should be limited to the V_{IN} operating range (36V) during overload conditions (short-circuit or start-up). Above $V_{IN(PS)}$, the part enters pulse-skipping mode.

Minimum On Time

For switching frequencies less than 750kHz, the part will still regulate the output at input voltages that exceed $V_{IN(PS)}$ (up to 40V), however, the output voltage ripple increases as the input voltage is increased. Figure 1 illustrates switching waveforms in continuous mode for a 3V output application near $V_{IN(PS)} = 33V$.

As the input voltage is increased, the part is required to switch for shorter periods of time. Delays associated with turning off the power switch determine the minimum on time of the part. The worst-case typical minimum on-time is 130ns. Figure 2 illustrates the switching waveforms when the input voltage is increased to $V_{IN} = 35V$.

Now the required on time has decreased below the minimum on time of 130ns. Instead of the switch pulse

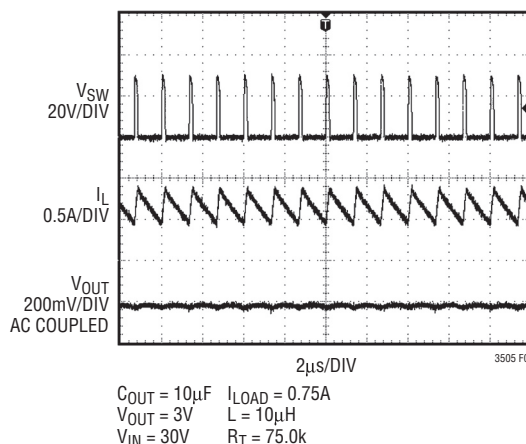

Figure 1

APPLICATIONS INFORMATION

width becoming narrower to accommodate the lower duty cycle requirement, the switch pulse width remains fixed at 130ns. In Figure 2 the inductor current ramps up to a value exceeding the load current and the output ripple increases to ~200mV. The part then remains off until the output voltage dips below 100% of the programmed value before it begins switching again.

Provided that the load can tolerate the increased output voltage ripple and that the components have been properly selected, operation above $V_{IN(PS)}$ is safe and will not damage the part. Figure 3 illustrates the switching waveforms when the input voltage is increased to its absolute maximum rating of 40V.

As the input voltage increases, the inductor current ramps up quicker, the number of skipped pulses increases and the

output voltage ripple increases. The part is robust enough to survive prolonged operation under these conditions as long as the peak inductor current does not exceed 2.2A. Inductor current saturation may further limit performance in this operating regime.

Frequency Selection

The maximum frequency that the LT3505 can be programmed to is 3MHz. The minimum frequency that the LT3505 can be programmed to is 200kHz. The switching frequency is programmed by tying a 1% resistor from the R_T pin to ground. Table 1 can be used to select the value of R_T . Minimum on-time and edge loss must be taken into consideration when selecting the intended frequency of operation.

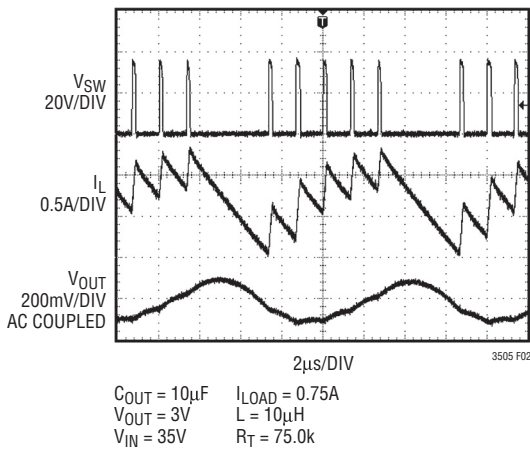

Figure 2

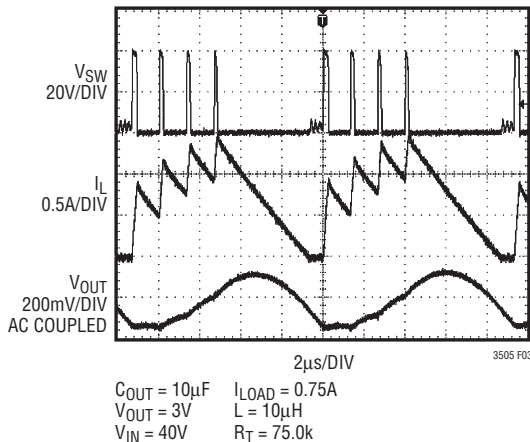

Figure 3

Table 1. R_T Pin Resistance

R_T PIN RESISTANCE (kΩ)	SWITCHING FREQUENCY (MHz)
357	0.20
237	0.30
165	0.40
124	0.50
100	0.60
84.5	0.69
71.5	0.80
61.9	0.91
54.9	1.00
48.7	1.11
44.2	1.21
40.2	1.31
37.4	1.39
34.0	1.50
31.6	1.60
29.4	1.70
27.4	1.80
25.5	1.90
23.7	2.02
22.6	2.10
21.0	2.22
20.0	2.31
19.1	2.39
18.2	2.48
16.9	2.62
16.2	2.71
15.4	2.81
14.7	2.90
13.7	3.01

APPLICATIONS INFORMATION

Finite transistor bandwidth limits the speed at which the power switch can be turned on and off, effectively setting the minimum on-time of the LT3505. For a given output voltage, the minimum on-time determines the maximum input voltage to remain in continuous mode operation, $V_{IN(PS)}$. See the “Input Voltage Range” section of the datasheet for more information on determining $V_{IN(PS)}$. For switching frequencies below 750kHz, operation above $V_{IN(PS)}$ (up to 40V) is safe provided that the system will tolerate the pulse-skipping behavior outlined in the “Minimum On Time” section of the datasheet. At switching frequencies exceeding 750kHz, edge loss limits operation to input voltages below $V_{IN(PS)}$.

Finite transition time results in a small amount of power dissipation each time the power switch turns on and off (edge loss). Edge loss increases with frequency, switch current, and input voltage.

Input Voltage Frequency Foldback

In continuous mode operation (below $V_{IN(PS)}$) edge loss only reduces the application efficiency. However, at high switching frequencies exceeding 750kHz and input voltages exceeding $V_{IN(PS)}$, the part will operate in a pulse-skipping mode and the switch current can increase above the current limit of the part, 1.75A. This further increases the power dissipated during switch transitions and results in an increased die temperature. To remedy the situation a single resistor (R5) and a zener diode (D3) can be added to a typical LT3505 circuit as shown in Figure 4.

When the input voltage is below 16V, the zener diode path conducts no current and the current flowing out of the R_T pin (and through R4) is nominally $0.5V/20k = 25\mu A$, which programs a 2.2MHz switching frequency. As the input voltage is increased above 16V, the zener diode begins to conduct and gradually reduces the current flowing out of the R_T pin. This mechanism reduces the switching frequency as the input voltage is increased above 16V (up to 36V) to ensure that the part constantly operates in continuous mode without skipping pulses, thereby preventing the excessive die temperature rise encountered in pulse-skipping mode.

Although the circuit can be operated indefinitely above V_{ZENER} , this frequency foldback method is intended to protect circuits during temporary periods of high input voltage. For example, in many automotive systems, the normal operating input range might be 9V to 16V, and the LT3505 can be programmed to operate above the AM band (>1.8MHz). At the same time, the circuit must be able to withstand higher input voltages due to load dump or double-battery jump starts. During these brief periods, it is usually acceptable to switch at a frequency within the AM band.

If the output is shorted while the input voltage is greater than V_{ZENER} , the switching frequency will be reduced to 30kHz and the part will not be able to recover from the short until the input voltage is reduced below V_{ZENER} (see the following discussion).

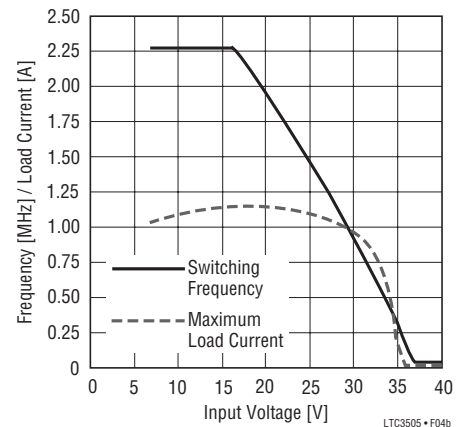
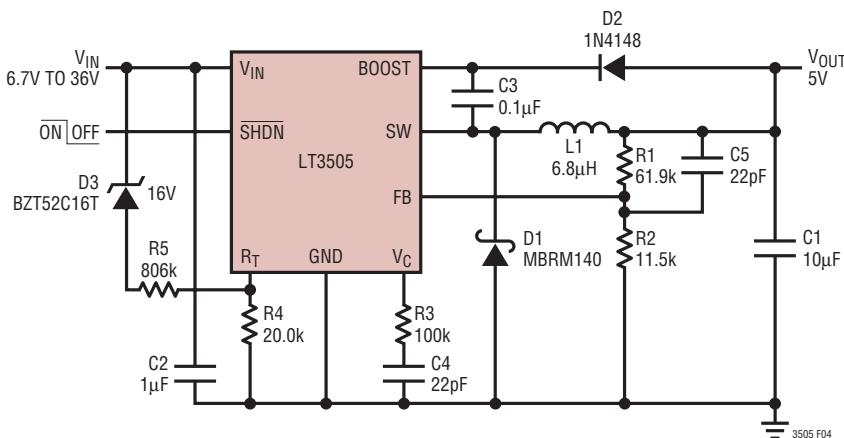

Figure 4. 2.2MHz, 5V Application with Input Voltage Frequency Foldback Circuit

APPLICATIONS INFORMATION

Component Selection for Input Voltage Frequency Foldback Circuit

To determine the values of R4, R5, and D3 for a specific application follow the procedure outlined in this section. First select the value of R4 from Table 1.

Second, determine the value of $V_{IN(PS)}$ from the equation in the “Input Voltage Range” section of the data sheet. Select the zener diode, D3, to have a breakdown voltage (V_{ZENER}) below $V_{IN(PS)}$. Next determine the desired foldback frequency from the following equation:

$$f_{SW(MIN)} = (V_{OUT} + V_D) / [t_{ON(MIN)} \cdot (V_{IN(MAX)} + V_D - V_{SW})]$$

where V_D is the forward drop of the catch diode (~0.4V), and V_{SW} is the voltage drop of the internal power switch (~0.4V at maximum load), $V_{IN(MAX)}$ is the maximum input voltage for the application (must be less than 36V), and $t_{ON(MIN)}$ is the worst-case minimum on-time for the intended application. The worst-case minimum on-time can be determined from the graphs in the “Typical Performance Characteristics” section of the datasheet. Next look up the resistance that corresponds to $f_{SW(MIN)}$ in Table 1. This resistance is $R_{T(MAX)}$, the effective resistance from the R_T pin to ground at $V_{IN(MAX)}$ that programs the oscillator to a switching frequency equal to $f_{SW(MIN)}$.

Finally determine R5 from the following equation:

$$R5 = 2 \cdot (V_{IN(MAX)} - V_{ZENER}) / (1/R4 - 1/R_{T(MAX)})$$

where V_{ZENER} is the zener diode breakdown voltage, and $V_{IN(MAX)}$ is the maximum input voltage that will be applied to the V_{IN} pin. $V_{IN(MAX)}$ must not exceed 36V, the maximum operating input voltage of the LT3505. The equation to determine R5 assumes that R5 will compensate a percentage of the current flowing through R4 equal to $R4/R_{T(MAX)}$. Be careful not to select a value of R5 much less than that determined by the equation above because it may become possible for R5 to compensate 100% of the current flowing through R4 reducing the frequency to 30kHz. In this state the part is not able to start into large output current loads.

Whenever the voltage at the FB pin is below 600mV, the LT3505 folds back the switching frequency by reducing the bias voltage at the R_T pin. If the input voltage is higher than the zener voltage, the reduced voltage at the R_T pin results in a larger voltage drop across R5, and a reduced voltage drop across R4. The current carried by R5 may be large enough to completely compensate the current flowing through R4, reducing the frequency to 30kHz. In this situation the input voltage will have to be reduced until the input voltage is less than the zener voltage.

Note that when V_{IN} is above V_{ZENER} and the frequency is reduced, the inductor ripple current will be higher and the maximum load that the LT3505 can regulate will be lower. See the Inductor Selection and Maximum Output Current section of this data sheet for more information.

Table 2. Inductor Vendors

VENDOR	URL	PART SERIES	INDUCTANCE RANGE (μH)	Size (mm)
Sumida	www.sumida.com	CDRH4D28 CDRH5D28 CDRH5D28	1.2 to 4.7 2.5 to 10 2.5 to 33	4.5 × 4.5 5.5 × 5.5 8.3 × 8.3
Toko	www.toko.com	A916CY D585LC	2 to 12 1.1 to 39	6.3 × 6.2 8.1 × 8.0
Würth Elektronik	www.we-online.com	WE-TPC(M) WE-PD2(M) WE-PD(S)	1 to 10 2.2 to 22 1 to 27	4.8 × 4.8 5.2 × 5.8 7.3 × 7.3

APPLICATIONS INFORMATION

Inductor Selection and Maximum Output Current

A good first choice for the inductor value is:

$$L = 1.2 (V_{OUT} + V_D) / f_{SW}$$

where V_D is the voltage drop of the catch diode ($\sim 0.4V$), L is in μH and f_{SW} is in MHz. With this value there will be no subharmonic oscillation for applications with 50% or greater duty cycle. The inductor's RMS current rating must be greater than your maximum load current and its saturation current should be about 30% higher. For robust operation in fault conditions, the saturation current should be above 2.2A. To keep efficiency high, the series resistance (DCR) should be less than 0.1Ω . Table 2 lists several vendors and types that are suitable.

Of course, such a simple design guide will not always result in the optimum inductor for your application. A larger value provides a higher maximum load current and reduces output voltage ripple at the expense of slower transient response. If your load is lower than 1.2A, then you can decrease the value of the inductor and operate with higher ripple current. This allows you to use a physically smaller inductor, or one with a lower DCR resulting in higher efficiency. There are several graphs in the Typical Performance Characteristics section of this data sheet that show the maximum load current as a function of input voltage and inductor value for several popular output voltages. Low inductance may result in discontinuous mode operation, which is okay, but further reduces maximum load current. For details on maximum output current and discontinuous mode operation, see Linear Technology Application Note 44.

Catch Diode

Depending on load current, a 1A to 2A Schottky diode is recommended for the catch diode, D1. The diode must have a reverse voltage rating equal to or greater than the maximum input voltage. The ON Semiconductor MBRM140 is a good choice; it is rated for 1A continuous forward current and a maximum reverse voltage of 40V.

Input Capacitor

The input of the LT3505 circuit must be bypassed with a X7R or X5R type ceramic capacitor. Y5V types have poor performance over temperature and applied voltage and should not be used. For switching frequencies higher than 750kHz, bypass the input with a $1\mu F$ or higher value ceramic capacitor. For switching frequencies below 750kHz, bypass the input with a $2.2\mu F$ or higher value ceramic capacitor. If the input power source has high impedance, or there is significant inductance due to long wires or cables, additional bulk capacitance may be necessary. This can be provided with a low performance electrolytic capacitor.

Step-down regulators draw current from the input supply in pulses with very fast rise and fall times. The input capacitor is required to reduce the resulting voltage ripple at the LT3505 and to force this very high frequency switching current into a tight local loop, minimizing EMI. To accomplish this task, the input bypass capacitor must be placed close to the LT3505 and the catch diode; see the PCB Layout section. A second precaution regarding the ceramic input capacitor concerns the maximum input voltage rating of the LT3505. A ceramic input capacitor combined with trace or cable inductance forms a high quality (underdamped) tank circuit. If the LT3505 circuit is plugged into a live supply, the input voltage can ring to twice its nominal value, possibly exceeding the LT3505's voltage rating. This situation can be easily avoided; see the Hot Plugging Safely section.

Output Capacitor

The output capacitor has two essential functions. Along with the inductor, it filters the square wave generated by the LT3505 to produce the DC output. In this role it determines the output ripple so low impedance at the switching frequency is important. The second function is to store energy in order to satisfy transient loads and stabilize the LT3505's control loop.

APPLICATIONS INFORMATION

Ceramic capacitors have very low equivalent series resistance (ESR) and provide the best ripple performance. A good value is:

$$C_{OUT} = 49 / (V_{OUT} \cdot f_{SW})$$

where C_{OUT} is in μF and f_{SW} is in MHz. Use X5R or X7R types and keep in mind that a ceramic capacitor biased with V_{OUT} will have less than its nominal capacitance. This choice will provide low output ripple and good transient response. Transient performance can be improved with a high value capacitor, if the compensation network is also adjusted to maintain the loop bandwidth.

A lower value of output capacitor can be used, but transient performance will suffer unless the compensation network is adjusted to reduce the loop gain. Also, a lower value output capacitor may result in increased sensitivity to noise which can be alleviated by adding a 22pF phase lead capacitor from FB to V_{OUT} .

High performance electrolytic capacitors can be used for the output capacitor. Low ESR is important, so choose one that is intended for use in switching regulators. The ESR should be specified by the supplier and should be 0.1Ω or less. Such a capacitor will be larger than a ceramic capacitor and will have a larger capacitance, because the capacitor must be large to achieve low ESR. Table 3 lists several capacitor vendors.

Figure 5 shows the transient response of the LT3505 with several output capacitor choices. The output is 3.3V. The load current is stepped from 500mA to 1.2A and back to 500mA and the oscilloscope traces show the output

voltage. The upper photo shows the recommended value. The second photo shows the improved response (less voltage drop) resulting from a larger output capacitor and a larger phase lead capacitor. The last photo shows the response to a high performance electrolytic capacitor. Transient performance is improved due to the large output capacitance.

BOOST Pin Considerations

Capacitor C3 and diode D2 are used to generate a boost voltage that is higher than the input voltage. In most cases a $0.1\mu\text{F}$ capacitor and fast switching diode (such as the 1N4148 or 1N914) will work well. Figure 6 shows two ways to arrange the boost circuit. The BOOST pin must be at least 2.3V above the SW pin for best efficiency. For outputs of 3.3V and above, the standard circuit (Figure 6a) is best. For outputs between 3V and 3.3V, use a $0.22\mu\text{F}$ capacitor. For outputs between 2.5V and 3V, use a $0.47\mu\text{F}$ capacitor and a small Schottky diode (such as the BAT-54). For lower output voltages tie a Schottky diode to the input (Figure 6b). The circuit in Figure 6a is more efficient because the BOOST pin current comes from a lower voltage source. You must also be sure that the maximum voltage rating of the BOOST pin is not exceeded.

The minimum operating voltage of an LT3505 application is limited by the undervoltage lockout (3.6V) and by the maximum duty cycle as outlined above. For proper start-up, the minimum input voltage is also limited by the boost circuit. If the input voltage is ramped slowly, or the LT3505 is turned on with its $\overline{\text{SHDN}}$ pin when the output is already in regulation, then the boost capacitor

Table 3. Capacitor Vendors

VENDOR	PHONE	URL	PART SERIES	COMMENTS
Panasonic	(714) 373-7366	www.panasonic.com	Ceramic, Polymer, Tantalum	EEF Series
Kemet	(864) 963-6300	www.kemet.com	Ceramic, Tantalum	T494, T495
Sanyo	(408) 749-9714	www.sanyovideo.com	Ceramic, Polymer, Tantalum	POSCAP
Murata	(404) 436-1300	www.murata.com	Ceramic	
AVX		www.avxcorp.com	Ceramic, Tantalum	TPS Series
Taiyo Yuden	(864) 963-6300	www.taiyo-yuden.com	Ceramic	

3505fa

APPLICATIONS INFORMATION

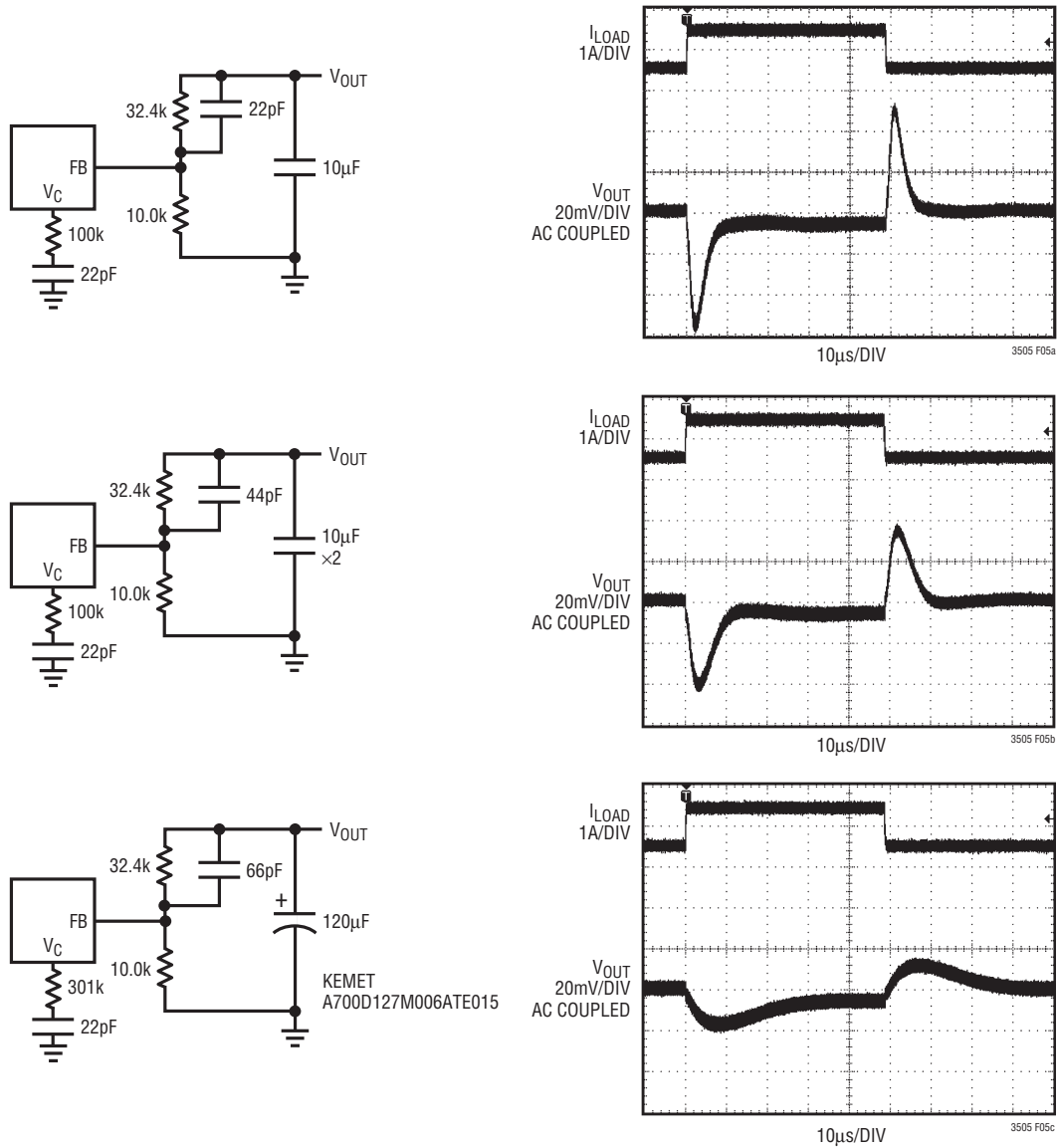

Figure 5. Transient Load Response of the LT3505 with Different Output Capacitors as the Load Current is Stepped from 500mA to 1.2A. $V_{IN} = 12V$, $V_{OUT} = 3.3V$, $L = 2\mu H$, $R_T = 20.0k$

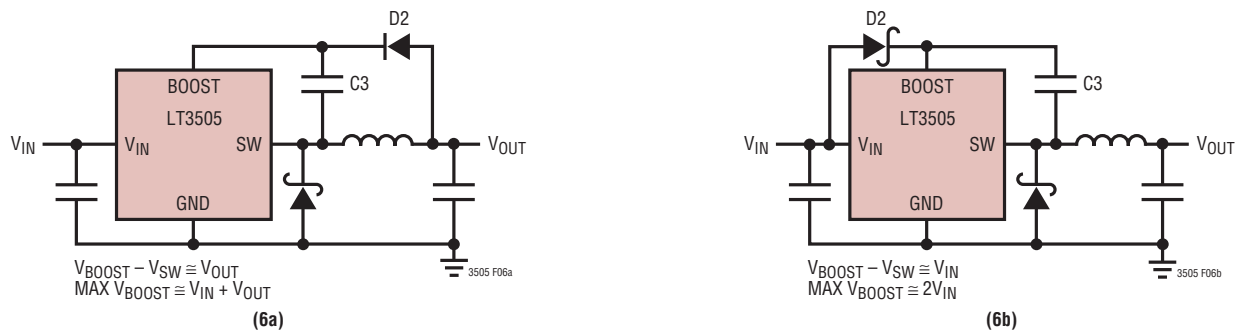

Figure 6. Two Circuits for Generating the Boost Voltage

APPLICATIONS INFORMATION

may not be fully charged. Because the boost capacitor is charged with the energy stored in the inductor, the circuit will rely on some minimum load current to get the boost circuit running properly. This minimum load will depend on the input and output voltages and on the arrangement of the boost circuit. The minimum load generally goes to zero once the circuit has started. Figure 7 shows a plot of minimum load to start and to run as a function of input voltage. In many cases the discharged output capacitor will present a load to the switcher which will allow it to start. The plots show the worst-case situation where V_{IN} is ramping very slowly. For lower start-up voltage, the boost diode can be tied to V_{IN} ; however this restricts the input range to one-half of the absolute maximum rating of the BOOST pin.

At light loads, the inductor current becomes discontinuous and the effective duty cycle can be very high. This reduces the minimum input voltage to approximately 400mV above V_{OUT} . At higher load currents, the inductor current is continuous and the duty cycle is limited by the maximum duty cycle of the LT3505, requiring a higher input voltage to maintain regulation.

Soft-Start

The $\overline{\text{SHDN}}$ pin can be used to soft-start the LT3505, reducing the maximum input current during start-up. The $\overline{\text{SHDN}}$ pin is driven through an external RC filter to create a voltage ramp at this pin. Figure 8 shows the start-up waveforms with and without the soft-start circuit. By choosing a large RC time constant, the peak start up current can be reduced to the current that is required to regulate the output, with no overshoot. Choose the value of the resistor so that it can supply 20 μA when the SHDN pin reaches 2.3V.

Shorted and Reversed Input Protection

If the inductor is chosen so that it won't saturate excessively, an LT3505 buck regulator will tolerate a shorted output. There is another situation to consider in systems where the output will be held high when the input to the LT3505 is absent. This may occur in battery charging applications or in battery backup systems where a battery or some other supply is diode OR-ed with the LT3505's output. If the V_{IN} pin is allowed to float and the $\overline{\text{SHDN}}$ pin is held high (either by a logic signal or because it is tied to V_{IN}), then the LT3505's internal circuitry will pull its

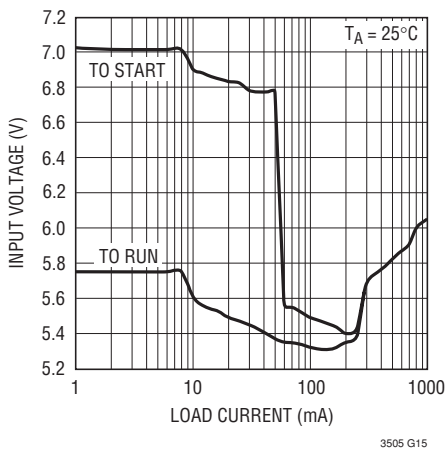

(7a) Typical Minimum Input Voltage, $V_{OUT} = 5\text{V}$, $f_{SW} = 750\text{kHz}$

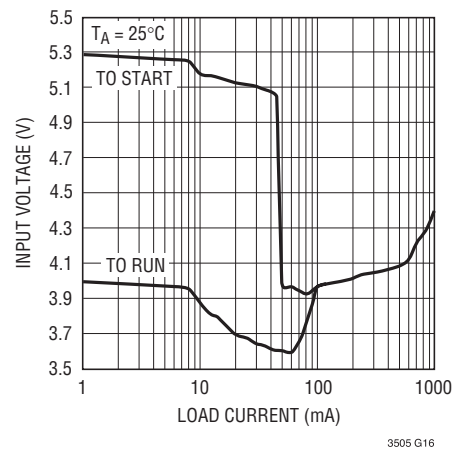

(7b) Typical Minimum Input Voltage, $V_{OUT} = 3.3\text{V}$, $f_{SW} = 750\text{kHz}$

Figure 7

APPLICATIONS INFORMATION

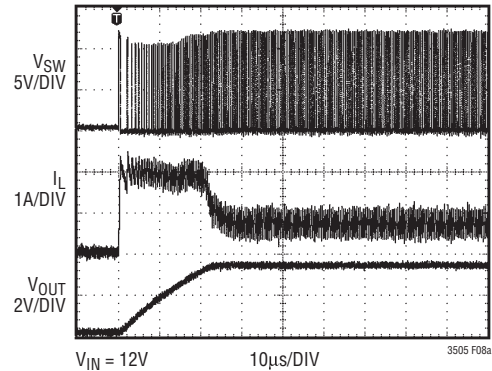

$V_{IN} = 12V$
 $V_{OUT} = 3.3V$
 $L = 2.5\mu H$
 $C_{OUT} = 10\mu F$
 $R_T = 20.0k$

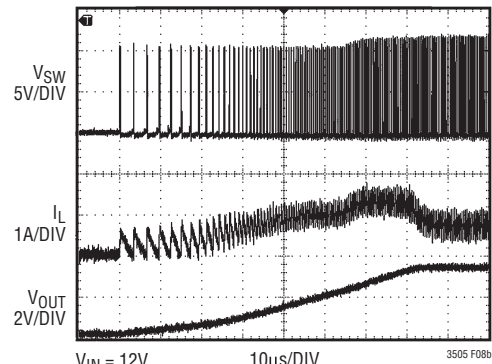

$V_{IN} = 12V$
 $V_{OUT} = 3.3V$
 $L = 2.5\mu H$
 $C_{OUT} = 10\mu F$
 $R_T = 20.0k$

Figure 8. To Soft-Start the LT3505, Add a Resistor and Capacitor to the SHDN pin.
 $V_{IN} = 12V$, $V_{OUT} = 3.3V$, $C_{OUT} = 10\mu F$, $R_{LOAD} = 5\Omega$, $R_T = 20.0k$, $L = 2.5\mu H$

quiescent current through its SW pin. This is fine if your system can tolerate a few mA in this state. If you ground the SHDN pin, the SW pin current will drop to essentially zero. However, if the V_{IN} pin is grounded while the output is held high, then parasitic diodes inside the LT3505 can pull large currents from the output through the SW pin and the V_{IN} pin. Figure 9 shows a circuit that will run only when the input voltage is present and that protects against a shorted or reversed input.

Hot Plugging Safely

The small size, robustness and low impedance of ceramic capacitors make them an attractive option for the input

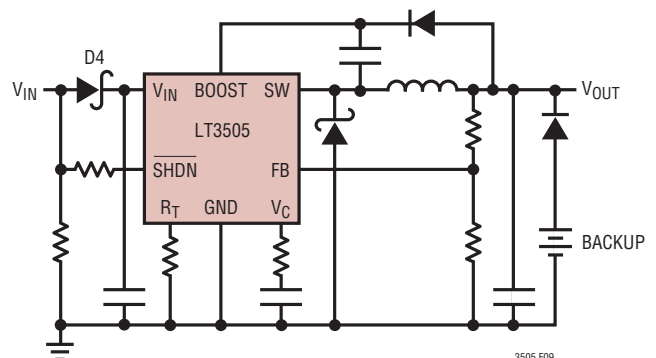

Figure 9. Diode D4 Prevents a Shorted Input from Discharging a Backup Battery Tied to the Output; It Also Protects the Circuit from a Reversed Input. The LT3505 Runs Only When the Input is Present

APPLICATIONS INFORMATION

bypass capacitor of LT3505 circuits. However, these capacitors can cause problems if the LT3505 is plugged into a live supply (see Linear Technology Application Note 88 for a complete discussion). The low loss ceramic capacitor combined with stray inductance in series with the power source forms an underdamped tank circuit and the voltage at the V_{IN} pin of the LT3505 can ring to twice the nominal input voltage, possibly exceeding the LT3505's rating and damaging the part. If the input supply is poorly controlled or the user will be plugging the LT3505 into an energized supply, the input network should be designed to prevent this overshoot.

Figure 10 shows the waveforms that result when an LT3505 circuit is connected to a 24V supply through six feet of 24-gauge twisted pair. The first plot is the response with a 2.2 μ F ceramic capacitor at the input. The input voltage rings as high as 35V and the input current peaks at 20A. One method of damping the tank circuit is to add another capacitor with a series resistor to the circuit. In Figure 9b

an aluminum electrolytic capacitor has been added. This capacitor's high equivalent series resistance damps the circuit and eliminates the voltage overshoot. The extra capacitor improves low frequency ripple filtering and can slightly improve the efficiency of the circuit, though it is likely to be the largest component in the circuit. An alternative solution is shown in Figure 9c. A 1 Ω resistor is added in series with the input to eliminate the voltage overshoot (it also reduces the peak input current). A 0.1 μ F capacitor improves high frequency filtering. This solution is smaller and less expensive than the electrolytic capacitor. For high input voltages its impact on efficiency is minor, reducing efficiency only one percent for a 5V output at full load operating from 24V.

Frequency Compensation

The LT3505 uses current mode control to regulate the output. This simplifies loop compensation. In particular, the LT3505 does not require the ESR of the output capaci-

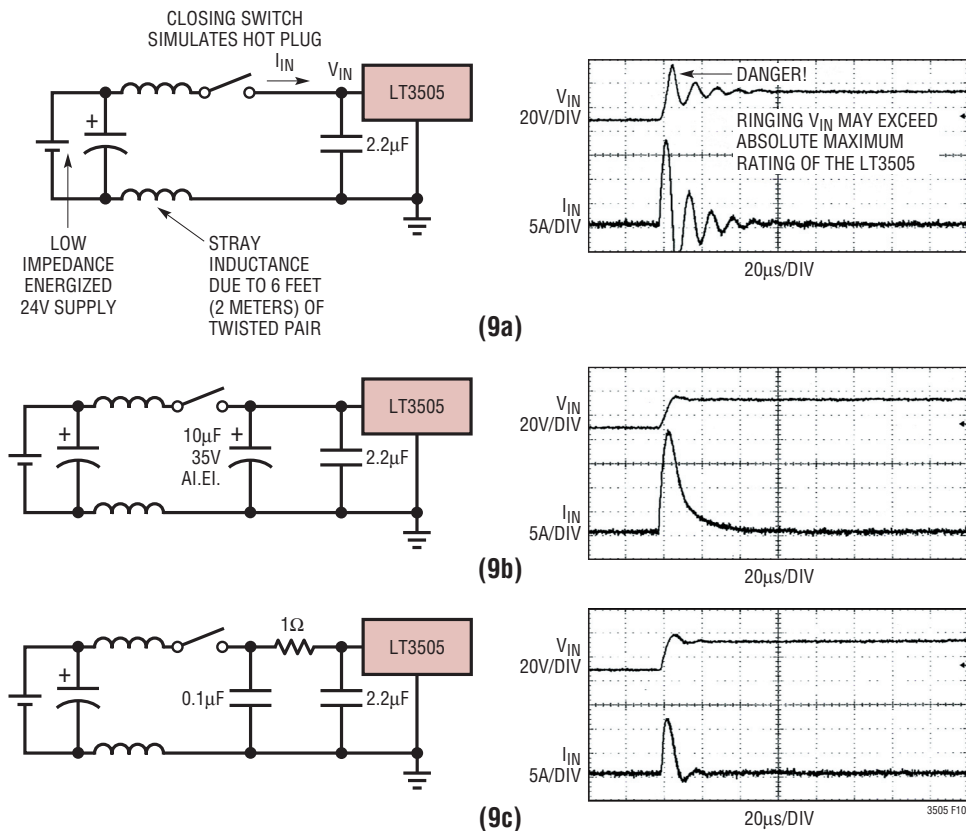

Figure 10. A Well Chosen Input Network Prevents Input Voltage Overshoot and Ensures Reliable Operation When the LT3505 is Connected to a Live Supply

APPLICATIONS INFORMATION

tor for stability allowing the use of ceramic capacitors to achieve low output ripple and small circuit size.

Frequency compensation is provided by the components tied to the V_C pin, as shown in Figure 10. Generally a capacitor (C_C) and a resistor (R_C) in series to ground are used. In addition, a lower value filter capacitor (C_F) may be added in parallel. The filter capacitor is not a part of the loop compensation but is used to filter noise at the switching frequency, and is required only if a phase-lead capacitor is used or if the output capacitor has high ESR.

Loop compensation determines the stability and transient performance. Designing the compensation network is a bit complicated and the best values depend on the application and in particular the type of output capacitor. A practical approach is to start with one of the circuits in this data sheet that is similar to your application and tune the compensation network to optimize the performance. Stability should then be checked across all operating conditions, including load current, input voltage and temperature. The LT1375 data sheet contains a more thorough discussion of loop compensation and describes how to test the stability using a transient load.

Figure 11 shows an equivalent circuit for the LT3505 control loop. The error amp is a transconductance amplifier with finite output impedance. The power section, consisting of the modulator, power switch and inductor, is modeled as

a transconductance amplifier generating an output current proportional to the voltage at the V_C node. Note that the output capacitor integrates this current and that the capacitor on the V_C node (C_C) integrates the error amplifier output current, resulting in two poles in the loop. R_C provides a zero. With the recommended output capacitor, the loop crossover occurs above the $R_C C_C$ zero. This simple model works well as long as the value of the inductor is not too high and the loop crossover frequency is much lower than the switching frequency. With a larger ceramic capacitor (very low ESR), crossover may be lower and a phase lead capacitor (C_{PL}) across the feedback divider may improve the phase margin and transient response. Large electrolytic capacitors may have an ESR large enough to create an additional zero and the phase lead may not be necessary.

If the output capacitor is different than the recommended capacitor, stability should be checked across all operating conditions, including load current, input voltage and temperature.

PCB Layout

For proper operation and minimum EMI, care must be taken during printed circuit board layout. Figure 12 shows the recommended component placement with trace, ground

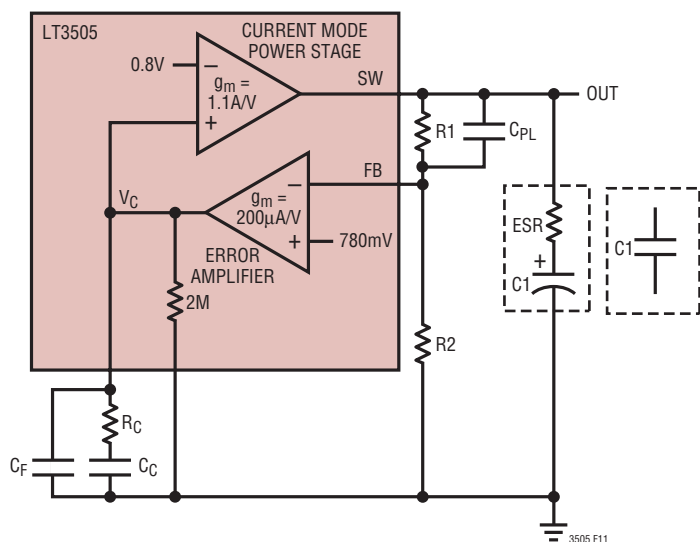

Figure 11. Model for Loop Response

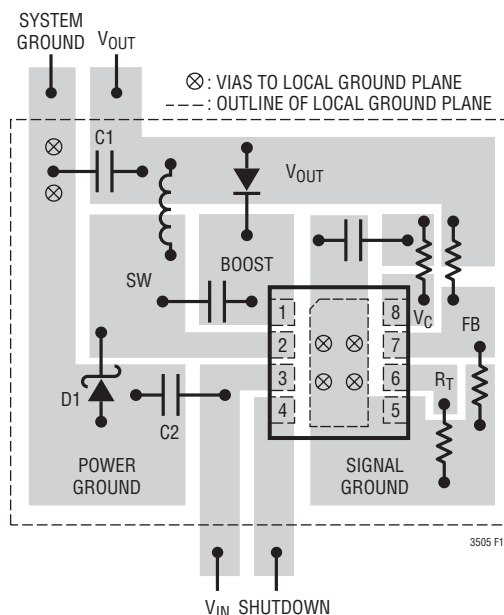

Figure 12. A Good PCB Layout Ensures Proper, Low EMI Operation

APPLICATIONS INFORMATION

plane and via locations. Note that large, switched currents flow in the LT3505's V_{IN} and SW pins, the catch diode (D1) and the input capacitor (C2). The loop formed by these components should be as small as possible and tied to system ground in only one place. These components, along with the inductor and output capacitor, should be placed on the same side of the circuit board and their connections should be made on that layer. Place a local, unbroken ground plane below these components and tie this ground plane to system ground at one location, ideally at the ground terminal of the output capacitor C1. The SW and BOOST nodes should be as small as possible. Finally, keep the FB node small so that the ground pin and ground traces will shield it from the SW and BOOST nodes. Include vias near the exposed GND pad of the LT3505 to help remove heat from the LT3505 to the ground plane.

High Temperature Considerations

The die temperature of the LT3505 must be lower than the maximum rating of 125°C. This is generally not a concern unless the ambient temperature is above 85°C. For higher temperatures, care should be taken in the layout of the circuit to ensure good heat sinking of the LT3505. The maximum load current should be derated as the ambient temperature approaches 125°C. The die temperature is calculated by multiplying the LT3505 power dissipation

by the thermal resistance from junction to ambient. Power dissipation within the LT3505 can be estimated by calculating the total power loss from an efficiency measurement and subtracting the catch diode loss. Thermal resistance depends on the layout of the circuit board, but 43°C/W is typical for the (3mm × 3mm) DFN (DD) package.

Outputs Greater Than 6V

For outputs greater than 6V, add a 1k to 2.5k resistor across the inductor to damp the discontinuous ringing of the SW node, preventing unintended SW current. The 12V Step-Down Converter circuit in the Typical Applications section shows the location of this resistor. Also note that for outputs above 10V, the input voltage range will be limited by the maximum rating of the BOOST pin. The 12V circuit shows how to overcome this limitation using an additional zener diode.

Other Linear Technology Publications

Application notes AN19, AN35 and AN44 contain more detailed descriptions and design information for Buck regulators and other switching regulators. The LT1376 data sheet has a more extensive discussion of output ripple, loop compensation and stability testing. Design Note DN100 shows how to generate a bipolar output supply using a Buck regulator.

TYPICAL APPLICATIONS

2.2MHz, 3.3V Step-Down Converter

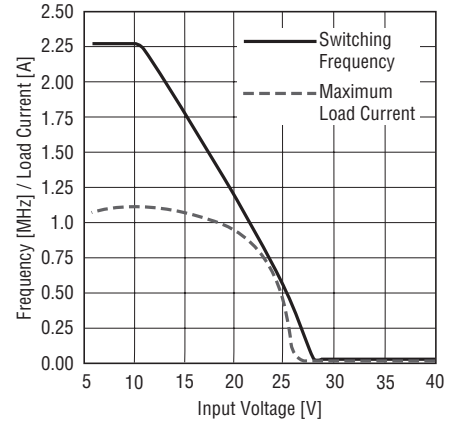
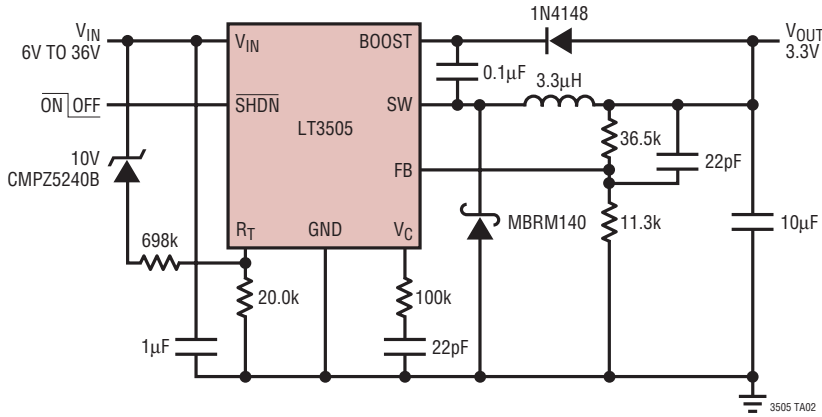

LT3505 • TA02b

1.2MHz, 1.8V Step-Down Converter

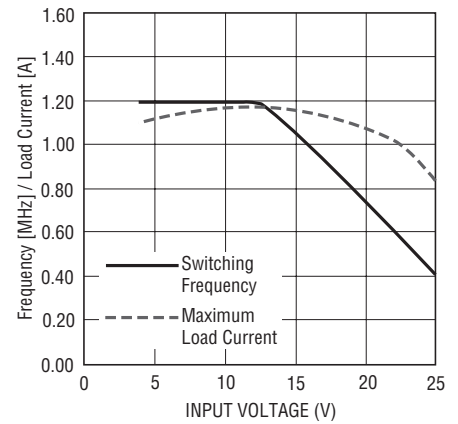
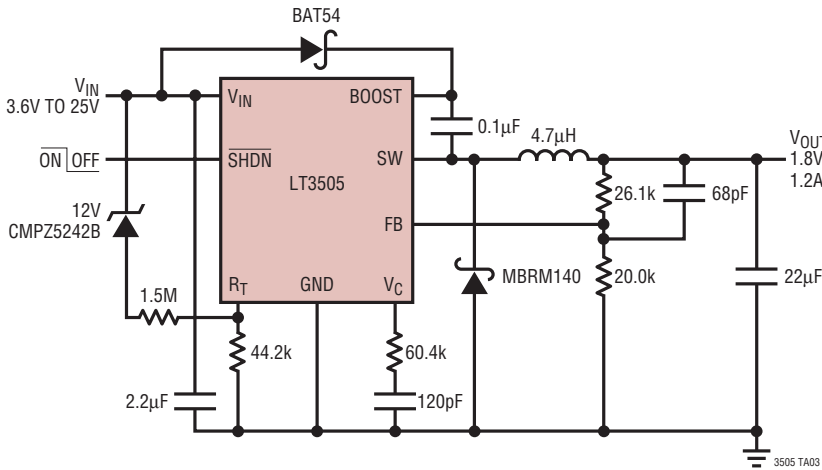

LT3505 • TA03b

TYPICAL APPLICATIONS

750kHz, 3.3V Step-Down Converter

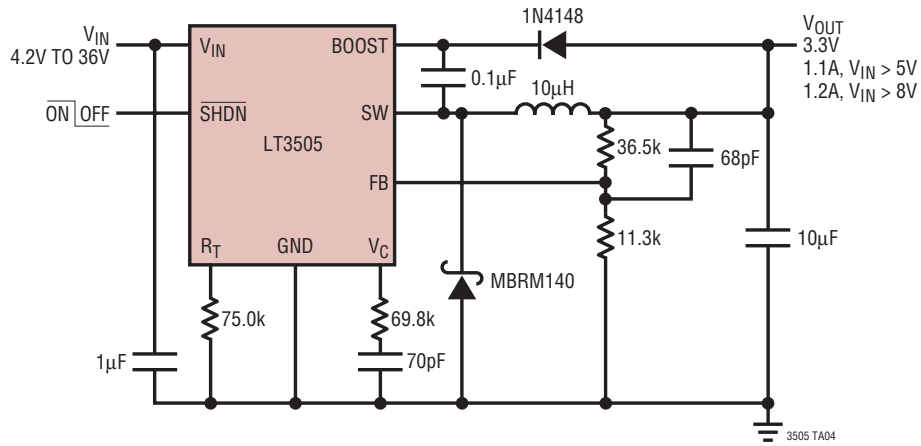

1MHz, 12V Step-Down Converter

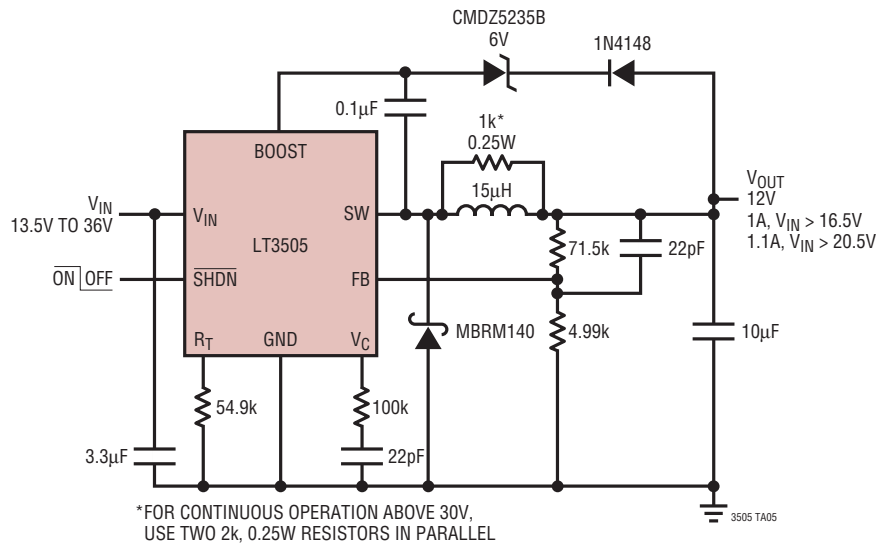

PACKAGE DESCRIPTION

DD Package 8-Lead Plastic DFN (3mm × 3mm) (Reference LTC DWG # 05-08-1698)

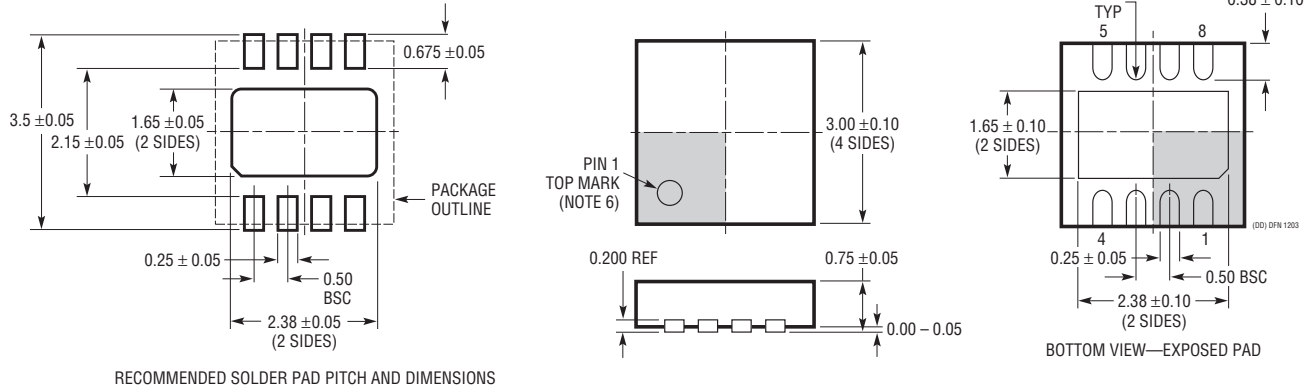

NOTE:

- DRAWING TO BE MADE A JEDEC PACKAGE OUTLINE M0-229 VARIATION OF (WEED-1)
- DRAWING NOT TO SCALE
- ALL DIMENSIONS ARE IN MILLIMETERS
- DIMENSIONS OF EXPOSED PAD ON BOTTOM OF PACKAGE DO NOT INCLUDE MOLD FLASH. MOLD FLASH, IF PRESENT, SHALL NOT EXCEED 0.15mm ON ANY SIDE
- EXPOSED PAD SHALL BE SOLDER PLATED
- SHADED AREA IS ONLY A REFERENCE FOR PIN 1 LOCATION ON TOP AND BOTTOM OF PACKAGE

MS8E Package 8-Lead Plastic MSOP (Reference LTC DWG # 05-08-1662)

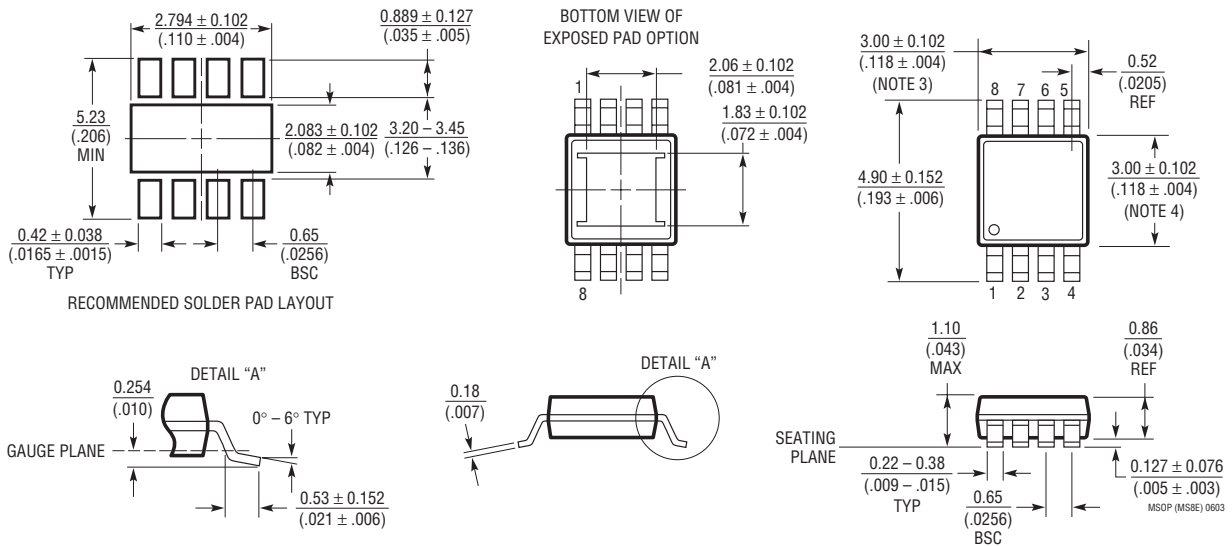

NOTE:

- DIMENSIONS IN MILLIMETER/(INCH)
- DRAWING NOT TO SCALE
- DIMENSION DOES NOT INCLUDE MOLD FLASH, PROTRUSIONS OR GATE BURRS. MOLD FLASH, PROTRUSIONS OR GATE BURRS SHALL NOT EXCEED 0.152mm (.006") PER SIDE
- DIMENSION DOES NOT INCLUDE INTERLEAD FLASH OR PROTRUSIONS. INTERLEAD FLASH OR PROTRUSIONS SHALL NOT EXCEED 0.152mm (.006") PER SIDE
- LEAD COPLANARITY (BOTTOM OF LEADS AFTER FORMING) SHALL BE 0.102mm (.004") MAX

TYPICAL APPLICATIONS

300kHz, 3.3V Step-Down Converter

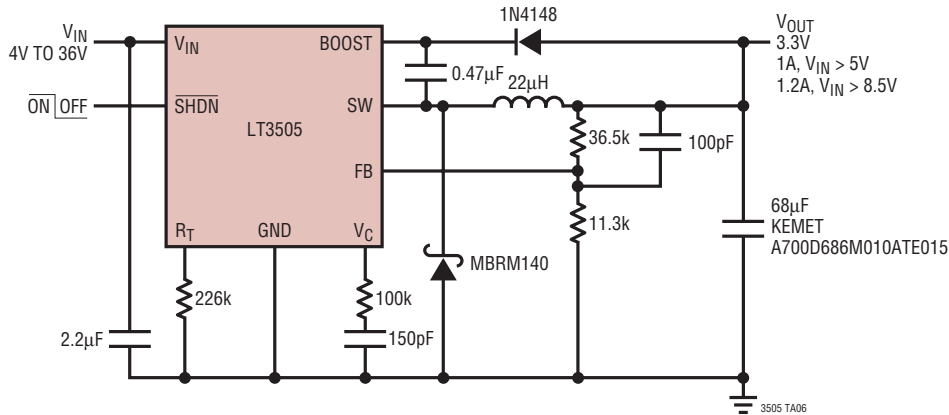

RELATED PARTS

PART NUMBER	DESCRIPTION	COMMENTS
LT1766	60V, 1.2A (I_{OUT}), 200kHz, High Efficiency Step-Down DC/DC Converter	V_{IN} : 5.5V to 60V, $V_{OUT(MIN)}$ = 1.2V, I_Q = 2.5mA, I_{SD} < 25µA, TSSOP16/TSSOP16E Packages
LT1767	25V, 1.2A (I_{OUT}), 1.25MHz, High Efficiency Step-Down DC/DC Converter	V_{IN} : 3V to 25V, $V_{OUT(MIN)}$ = 1.20V, I_Q = 1mA, I_{SD} < 6µA, MS8E Package
LT1933	500mA (I_{OUT}), 500kHz, Step-Down Switching Regulator in SOT-23	V_{IN} : 3.6V to 36V, $V_{OUT(MIN)}$ = 1.25V, I_Q = 1.6mA, I_{SD} < 1µA, TSSOP16/TSSOP16E Packages
LT1936	36V, 1.4A (I_{OUT}), 500kHz, High Efficiency Step-Down DC/DC Converter	V_{IN} : 3.6V to 36V, $V_{OUT(MIN)}$ = 1.20V, I_Q = 1.9mA, I_{SD} < 1µA, MS8E Package
LT1940	Dual 25V, 1.4A (I_{OUT}), 1.1MHz, High Efficiency Step-Down DC/DC Converter	V_{IN} : 3.6V to 25V, $V_{OUT(MIN)}$ = 1.25V, I_Q = 3.8mA, I_{SD} < 30µA, TSSOP16E Package
LT1976/LT1977	60V, 1.2A (I_{OUT}), 200kHz/500kHz, High Efficiency Step-Down DC/DC Converters with Burst Mode® Operation	V_{IN} : 3.3V to 60V, $V_{OUT(MIN)}$ = 1.25V, I_Q = 100µA, I_{SD} < 1µA, TSSOP16E Package
LT3434/LT3435	60V, 2.4A (I_{OUT}), 200kHz/500kHz, High Efficiency Step-Down DC/DC Converters with Burst Mode Operation	V_{IN} : 3.3V to 60V, $V_{OUT(MIN)}$ = 1.25V, I_Q = 100µA, I_{SD} < 1µA, TSSOP16E Package
LT3437	60V, 400mA (I_{OUT}), Micropower Step-Down DC/DC Converter with Burst Mode Operation	V_{IN} : 3.3V to 60V, $V_{OUT(MIN)}$ = 1.25V, I_Q = 100µA, I_{SD} = < 1µA, DFN Package
LT3493	36V, 1.2A (I_{OUT}), 750kHz, High Efficiency Step-Down DC/DC Converter	V_{IN} : 3.6V to 36V, $V_{OUT(MIN)}$ = 0.78V, I_Q = 1.9mA, I_{SD} < 2µA, DFN Package

Burst Mode is a registered trademark of Linear Technology Corporation.