

2Mx32 DRAM SIMM

(1MX16 Base)

www.DataSheet.in

Revision 0.0

November 1997

Revision History

Version 0.0 (November 1997)

- Changed module PCB from 6-Layer to 4-Layer.
- Changed Module Part No. from KMM5322204CW/CWG to KMM5322204C2W/C2WG caused by PCB revision .

www.DataSheet.in

KMM5322204C2W/C2WG Fast Page Mode with Extended Data Out
2M x 32 DRAM SIMM using 1Mx16 , 1K Refresh, 5V

GENERAL DESCRIPTION

The Samsung KMM5322204C2W is a 2Mx32bits Dynamic RAM high density memory module. The Samsung KMM5322204C2W consists of four CMOS 1Mx16bits DRAMs in 42-pin SOJ package mounted on a 72-pin glass-epoxy substrate. A 0.1 or 0.22uF decoupling capacitor is mounted on the printed circuit board for each DRAM. The KMM5322204C2W is a Single In-line Memory Module with edge connections and is intended for mounting into 72 pin edge connector sockets.

PERFORMANCE RANGE

Speed	tRAC	tCAC	trc	tHPC
-5	50ns	15ns	90ns	25ns
-6	60ns	15ns	110ns	30ns

FEATURES

- Part Identification
 - KMM5322204C2W(1024 cycles/16ms Ref, SOJ, Solder)
 - KMM5322204C2WG(1024 cycles/16ms Ref, SOJ, Gold)
- Fast Page Mode with Extended Data Out
- $\overline{\text{CAS}}$ -before- $\overline{\text{RAS}}$ refresh capability
- $\overline{\text{RAS}}$ -only and Hidden refresh capability
- TTL compatible inputs and outputs
- Single +5V±10% power supply
- JEDEC standard PDPin & pinout
- PCB : Height(750mil), double sided component

PIN CONFIGURATIONS

Pin	Symbol	Pin	Symbol
1	Vss	37	NC
2	DQ0	38	NC
3	DQ16	39	Vss
4	DQ1	40	$\overline{\text{CAS0}}$
5	DQ17	41	$\overline{\text{CAS2}}$
6	DQ2	42	$\overline{\text{CAS3}}$
7	DQ18	43	$\overline{\text{CAS1}}$
8	DQ3	44	$\overline{\text{RAS0}}$
9	DQ19	45	$\overline{\text{RAS1}}$
10	Vcc	46	NC
11	NC	47	$\overline{\text{W}}$
12	A0	48	NC
13	A1	49	DQ8
14	A2	50	DQ24
15	A3	51	DQ9
16	A4	52	DQ25
17	A5	53	DQ10
18	A6	54	DQ26
19	NC	55	DQ11
20	DQ4	56	DQ27
21	DQ20	57	DQ12
22	DQ5	58	DQ28
23	DQ21	59	Vcc
24	DQ6	60	DQ29
25	DQ22	61	DQ13
26	DQ7	62	DQ30
27	DQ23	63	DQ14
28	A7	64	DQ31
29	NC	65	DQ15
30	Vcc	66	NC
31	A8	67	PD1
32	A9	68	PD2
33	$\overline{\text{RAS1}}$	69	PD3
34	$\overline{\text{RAS0}}$	70	PD4
35	NC	71	NC
36	NC	72	Vss

PIN NAMES

Pin Name	Function
A0 - A9	Address Inputs
DQ0 - DQ31	Data In/Out
$\overline{\text{W}}$	Read/Write Enable
$\overline{\text{RAS0}}$, $\overline{\text{RAS1}}$	Row Address Strobe
$\overline{\text{CAS0}}$ - $\overline{\text{CAS3}}$	Column Address Strobe
PD1 -PD4	Presence Detect
Vcc	Power(+5V)
Vss	Ground
NC	No Connection
Res	Reserved Pin

PRESENCE DETECT PINS (Optional)

Pin	50NS	60NS
PD1	NC	NC
PD2	NC	NC
PD3	Vss	NC
PD4	Vss	NC

* Pin connection changing available

SAMSUNG ELECTRONICS CO., LTD. reserves the right to change products and specifications without notice.

FUNCTIONAL BLOCK DIAGRAM

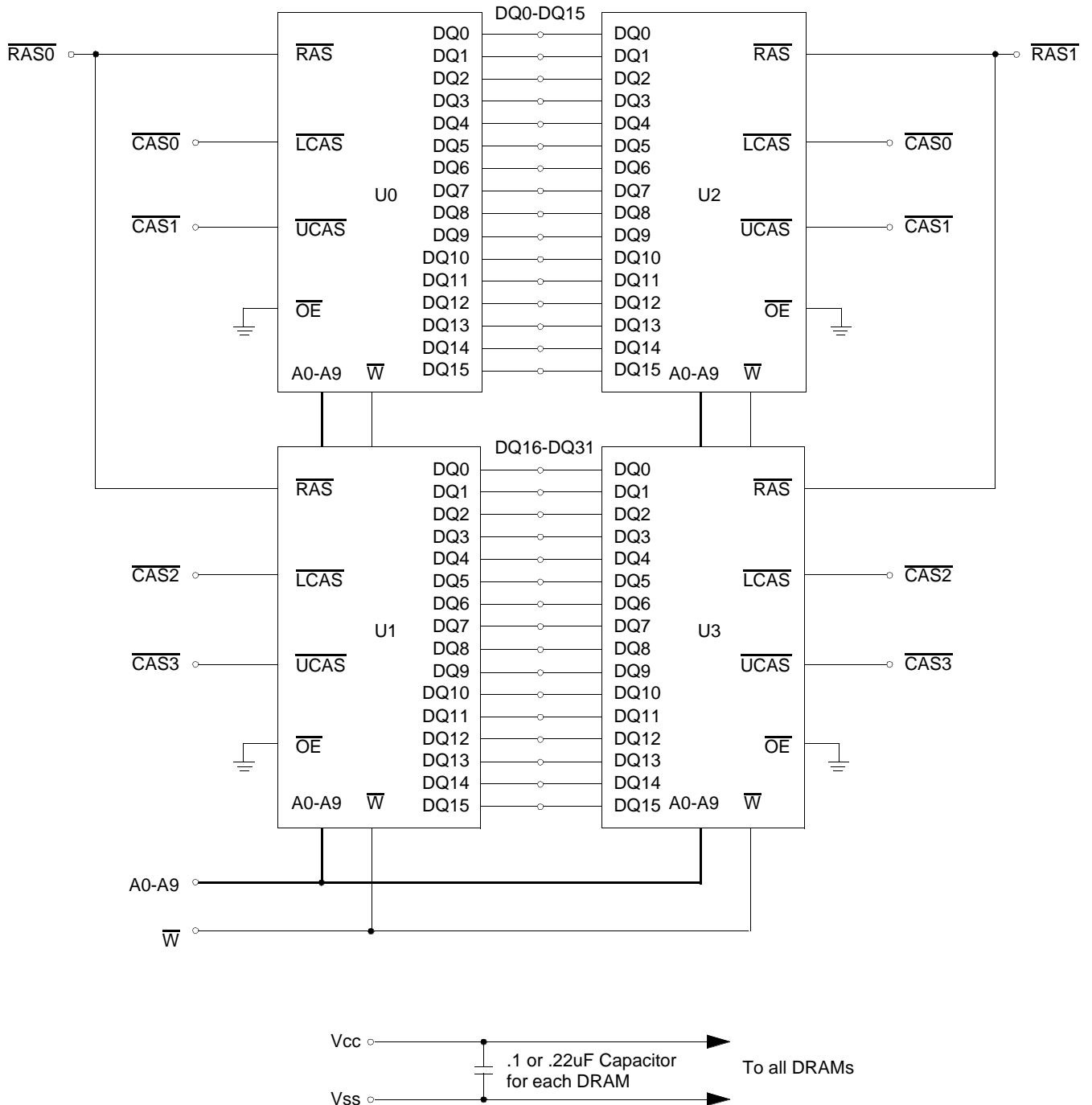

ABSOLUTE MAXIMUM RATINGS *

Item	Symbol	Rating	Unit
Voltage on any pin relative to V _{SS}	V _{IN} , V _{OUT}	-1 to +7.0	V
Voltage on V _{CC} supply relative to V _{SS}	V _{CC}	-1 to +7.0	V
Storage Temperature	T _{stg}	-55 to +150	°C
Power Dissipation	P _d	4	W
Short Circuit Output Current	I _{OS}	50	mA

* Permanent device damage may occur if ABSOLUTE MAXIMUM RATINGS are exceeded. Functional operation should be restricted to the conditions as detailed in the operational sections of this data sheet. Exposure to absolute maximum rating conditions for intended periods may affect device reliability.

RECOMMENDED OPERATING CONDITIONS (Voltage referenced to V_{SS}, T_A = 0 to 70°C)

Item	Symbol	Min	Typ	Max	Unit
Supply Voltage	V _{CC}	4.5	5.0	5.5	V
Ground	V _{SS}	0	0	0	V
Input High Voltage	V _{IH}	2.4	-	V _{CC} +1 ^{*1}	V
Input Low Voltage	V _{IL}	-1.0 ^{*2}	-	0.8	V

*1 : V_{CC}+2.0V/20ns, Pulse width is measured at V_{CC}.

*2 : -2.0V/20ns, Pulse width is measured at V_{SS}.

DC AND OPERATING CHARACTERISTICS (Recommended operating conditions unless otherwise noted)

Symbol	Speed	KMM5322204C2W/C2WG		Unit
		Min	Max	
I _{CC1}	-5	-	304	mA
	-6	-	284	mA
I _{CC2}	Don't care	-	8	mA
I _{CC3}	-5	-	304	mA
	-6	-	284	mA
I _{CC4}	-5	-	244	mA
	-6	-	224	mA
I _{CC5}	Don't care	-	4	mA
I _{CC6}	-5	-	304	mA
	-6	-	284	mA
I _{I(L)}	Don't care	-20	20	uA
I _{O(L)}	Don't care	-10	10	uA
V _{OH}	Don't care	2.4	-	V
V _{OL}	Don't care	-	0.4	V

I_{CC1} : Operating Current * (\overline{RAS} , \overline{CAS} , Address cycling @ t_{RC}=min)

I_{CC2} : Standby Current ($\overline{RAS}=\overline{CAS}=\overline{W}=V_{IH}$)

I_{CC3} : \overline{RAS} Only Refresh Current * ($\overline{CAS}=V_{IH}$, \overline{RAS} cycling @ t_{RC}=min)

I_{CC4} : EDO Mode Current * ($\overline{RAS}=V_{IL}$, \overline{CAS} cycling : t_{HPC}=min)

I_{CC5} : Standby Current ($\overline{RAS}=\overline{CAS}=\overline{W}=V_{CC}-0.2V$)

I_{CC6} : \overline{CAS} -Before- \overline{RAS} Refresh Current * (\overline{RAS} and \overline{CAS} cycling @ t_{RC}=min)

I_{I(L)} : Input Leakage Current (Any input 0 ≤ V_{IN} ≤ V_{CC}+0.5V, all other pins not under test=0 V)

I_{O(L)} : Output Leakage Current(Data Out is disabled, 0V ≤ V_{OUT} ≤ V_{CC})

V_{OH} : Output High Voltage Level (I_{OH} = -5mA)

V_{OL} : Output Low Voltage Level (I_{OL} = 4.2mA)

* **NOTE** : I_{CC1}, I_{CC3}, I_{CC4} and I_{CC6} are dependent on output loading and cycle rates. Specified values are obtained with the output open. I_{CC} is specified as an average current. In I_{CC1} and I_{CC3}, address can be changed maximum once while $\overline{RAS}=V_{IL}$. In I_{CC4}, address can be changed maximum once within one EDO mode cycle, t_{HPC}.

DRAM MODULE

KMM5322204C2W/C2WG

CAPACITANCE (TA = 25°C, VCC=5V, f = 1MHz)

Item	Symbol	Min	Max	Unit
Input capacitance[A0-A9]	CIN1	-	44	pF
Input capacitance[\overline{W}]	CIN2	-	48	pF
Input capacitance[$\overline{RAS0}$, $\overline{RAS1}$]	CIN3	-	40	pF
Input capacitance[$\overline{CAS0}$ - $\overline{CAS3}$]	CIN4	-	29	pF
Input/Output capacitance[DQ0-31]	CDQ1	-	29	pF

AC CHARACTERISTICS (0°C ≤ TA ≤ 70°C, VCC=5.0V±10%. See notes 1,2.)

Test condition : V_{ih}/V_{il}=2.4/0.8V, V_{oh}/V_{ol}=2.0/0.8V, Output loading CL=100pF

Parameter	Symbol	-5		-6		Unit	Note
		Min	Max	Min	Max		
Random read or write cycle time	t _{RC}	90		110		ns	
Access time from \overline{RAS}	t _{RAC}		50		60	ns	3,4,10
Access time from \overline{CAS}	t _{CAC}		15		17	ns	3,4,5
Access time from column address	t _{AA}		25		30	ns	3,10
\overline{CAS} to output in Low-Z	t _{CLZ}	3		3		ns	3
Output buffer turn-off delay from \overline{CAS}	t _{CEZ}	3	13	3	15	ns	6,11,12
Transition time(rise and fall)	t _T	2	50	2	50	ns	2
\overline{RAS} precharge time	t _{RP}	30		40		ns	
\overline{RAS} pulse width	t _{RAS}	50	10K	60	10K	ns	
\overline{RAS} hold time	t _{RSH}	13		17		ns	
\overline{CAS} hold time	t _{CSH}	40		50		ns	
\overline{CAS} pulse width	t _{CAS}	8	10K	10	10K	ns	13
\overline{RAS} to \overline{CAS} delay time	t _{RCD}	20	37	20	45	ns	4
\overline{RAS} to column address delay time	t _{RAD}	15	25	15	30	ns	10
\overline{CAS} to \overline{RAS} precharge time	t _{CRP}	5		5		ns	
Row address set-up time	t _{ASR}	0		0		ns	
Row address hold time	t _{RAH}	10		10		ns	
Column address set-up time	t _{ASC}	0		0		ns	
Column address hold time	t _{CAH}	8		10		ns	
Column address to \overline{RAS} lead time	t _{RAL}	25		30		ns	
Read command set-up time	t _{RCS}	0		0		ns	
Read command hold time referenced to \overline{CAS}	t _{RCH}	0		0		ns	8
Read command hold time referenced to \overline{RAS}	t _{RRH}	0		0		ns	8
Write command hold time	t _{WCH}	10		10		ns	
Write command pulse width	t _{WP}	10		10		ns	
Write command to \overline{RAS} lead time	t _{RWL}	13		15		ns	
Write command to \overline{CAS} lead time	t _{CWL}	13		10		ns	
Data-in set-up time	t _{DS}	0		0		ns	9
Data-in hold time	t _{DH}	8		10		ns	9
Refresh period	t _{REF}		16		16	ms	
Write command set-up time	t _{WCS}	0		0		ns	7
\overline{CAS} setup time(\overline{CAS} -before- \overline{RAS} refresh)	t _{CSR}	5		5		ns	
\overline{CAS} hold time(\overline{CAS} -before- \overline{RAS} refresh)	t _{CHR}	10		10		ns	
\overline{RAS} precharge to \overline{CAS} hold time	t _{RPC}	5		5		ns	
Access time from \overline{CAS} precharge	t _{CPA}		30		35	ns	3

AC CHARACTERISTICS (0°C ≤ T_A ≤ 70°C, V_{CC} = 5.0V ± 10%. See notes 1,2.)

Test condition : V_{IH}/V_{IL} = 2.4/0.8V, V_{OH}/V_{OL} = 2.0/0.8V, Output loading CL = 100pF

Parameter	Symbol	-5		-6		Unit	Note
		Min	Max	Min	Max		
Hyper page mode cycle time	tHPC	25		30		ns	13
$\overline{\text{CAS}}$ precharge time(Hyper page cycle)	tCP	8		10		ns	
$\overline{\text{RAS}}$ pulse width(Hyper page cycle)	tRASP	50	200K	60	200K	ns	
$\overline{\text{RAS}}$ hold time from $\overline{\text{CAS}}$ precharge	tRHCP	30		35		ns	
$\overline{\text{W}}$ to $\overline{\text{RAS}}$ precharge time(C-B-R refresh)	tWRP	10		10		ns	
$\overline{\text{W}}$ to $\overline{\text{RAS}}$ hold time(C-B-R refresh)	tWRH	10		10		ns	
Output data hold time	tDOH	5		5		ns	
Output buffer turn off delay from $\overline{\text{RAS}}$	tREZ	3	13	3	15	ns	6,11,12
Output buffer turn off delay from $\overline{\text{W}}$	tWEZ	3	13	3	15	ns	6,11
$\overline{\text{W}}$ to data delay	tWED	15		15		ns	
$\overline{\text{W}}$ pulse width (Hyper Page Cycle)	tWPE	5		5		ns	

NOTES

- An initial pause of 200us is required after power-up followed by any 8 RAS-only or CAS-before-RAS refresh cycles before proper device operation is achieved.
- V_{IH}(min) and V_{IL}(max) are reference levels for measuring timing of input signals. Transition times are measured between V_{IH}(min) and V_{IL}(max) and are assumed to be 5ns for all inputs.
- Measured with a load equivalent to 2 TTL loads and 100pF.
- Operation within the t_{RCD}(max) limit insures that t_{RAC}(max) can be met. t_{RCD}(max) is specified as a reference point only. If t_{RCD} is greater than the specified t_{RCD}(max) limit, then access time is controlled exclusively by t_{CAC}.
- Assumes that t_{RCD} ≥ t_{RCD}(max).
- This parameter defines the time at which the output achieves the open circuit condition and is not referenced to V_{OH} or V_{OL}.
- t_{WCS} is non-restrictive operating parameter. It is included in the data sheet as electrical characteristics only. If t_{WCS} ≥ t_{WCS}(min), the cycle is an early write cycle and the data out pin will remain high impedance for the duration of the cycle.
- Either t_{RCH} or t_{RRH} must be satisfied for a read cycle.
- These parameter are referenced to the $\overline{\text{CAS}}$ leading edge in early write cycles and to the $\overline{\text{W}}$ leading edge in read-write cycles.
- Operation within the t_{RAD}(max) limit insures that t_{RAC}(max) can be met. t_{RAD}(max) is specified as reference point only. If t_{RAD} is greater than the specified t_{RAD}(max) limit, then access time is controlled by t_{AA}.
- t_{CEZ}(max), t_{REZ}(max), t_{WEZ}(max) and t_{OEZ}(max) define the time at which the output achieves the open circuit condition and are not referenced to output voltage level.
- If $\overline{\text{RAS}}$ goes to high before $\overline{\text{CAS}}$ high going, the open circuit condition of the output is achieved by $\overline{\text{CAS}}$ high going. If $\overline{\text{CAS}}$ goes to high before $\overline{\text{RAS}}$ high going, the open circuit condition of the output is achieved by $\overline{\text{RAS}}$ high going.
- t_{ASC} ≥ t_{CP} min

READ CYCLE

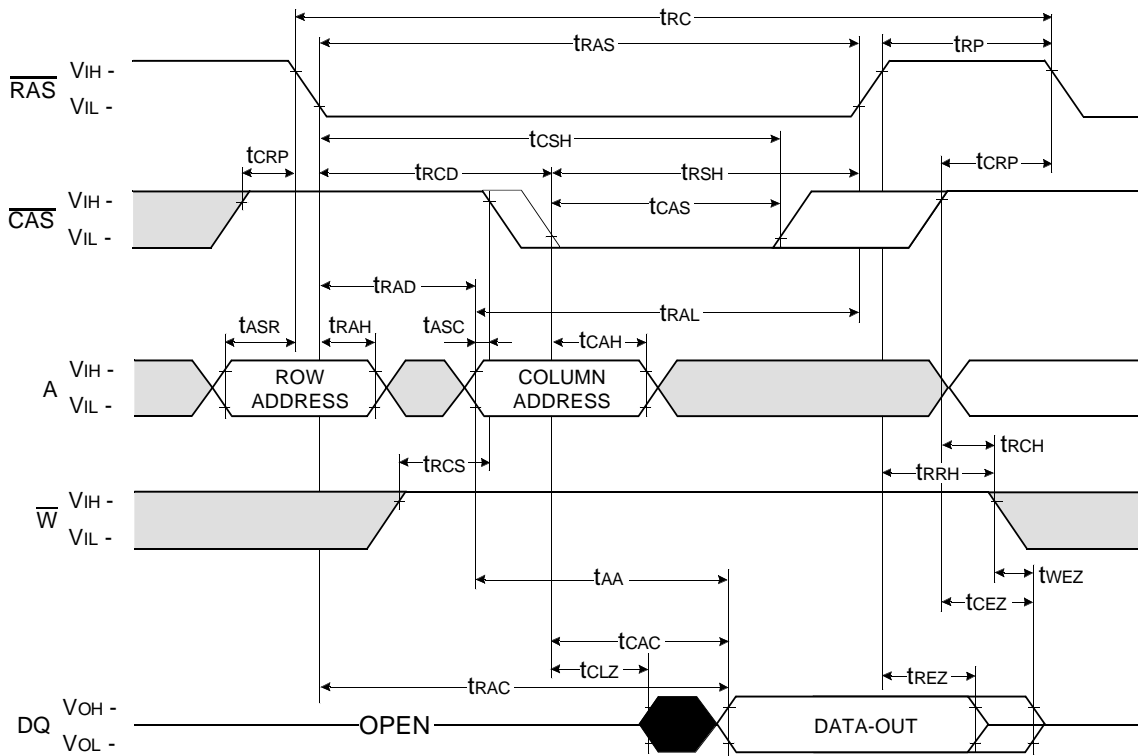

WRITE CYCLE (EARLY WRITE)

NOTE : DOUT = OPEN

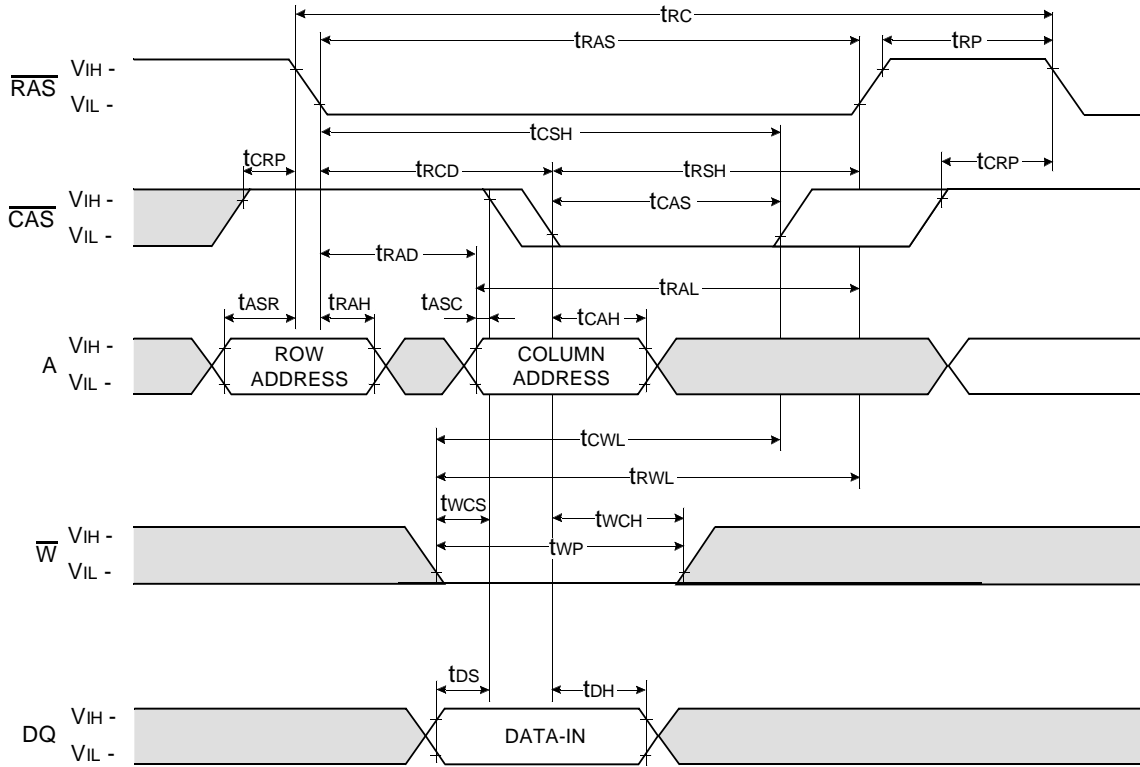

□ Don't care
 ■ Undefined

HYPER PAGE READ CYCLE

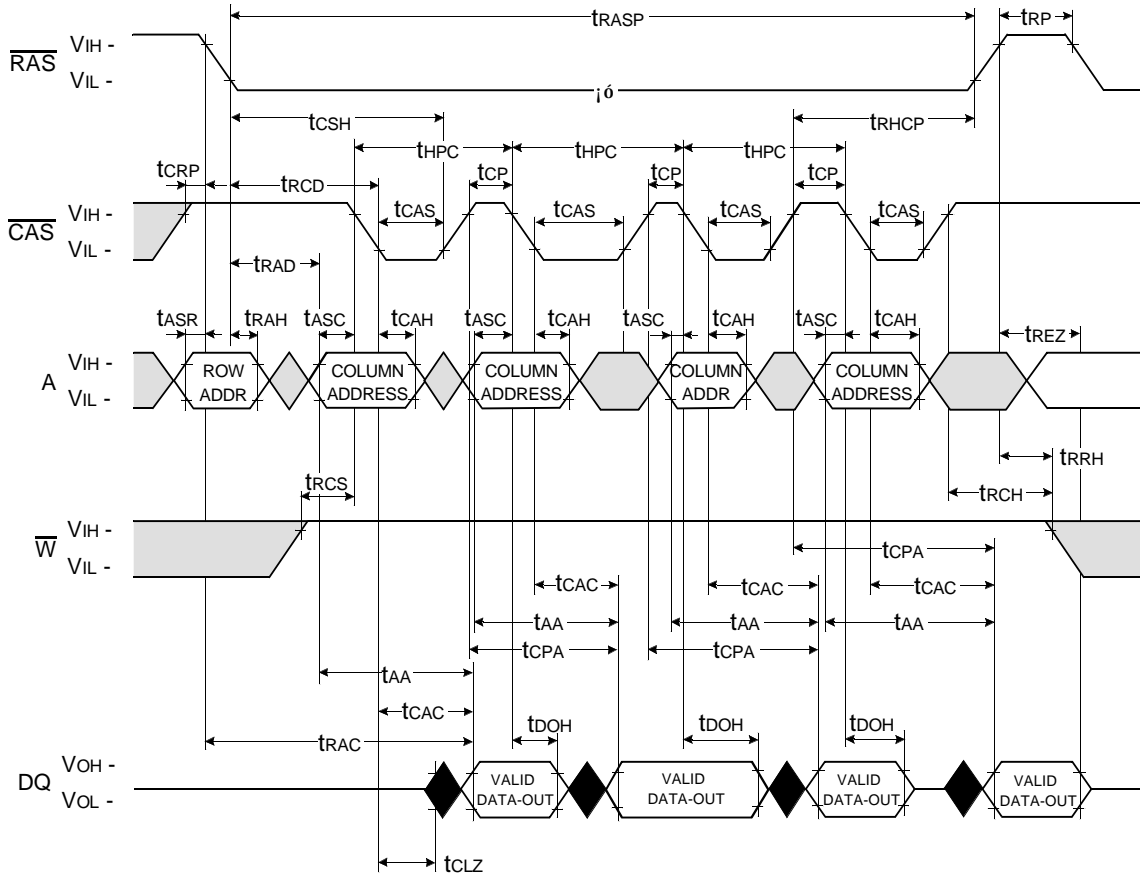

HYPER PAGE WRITE CYCLE (EARLY WRITE)

NOTE : DOUT = OPEN

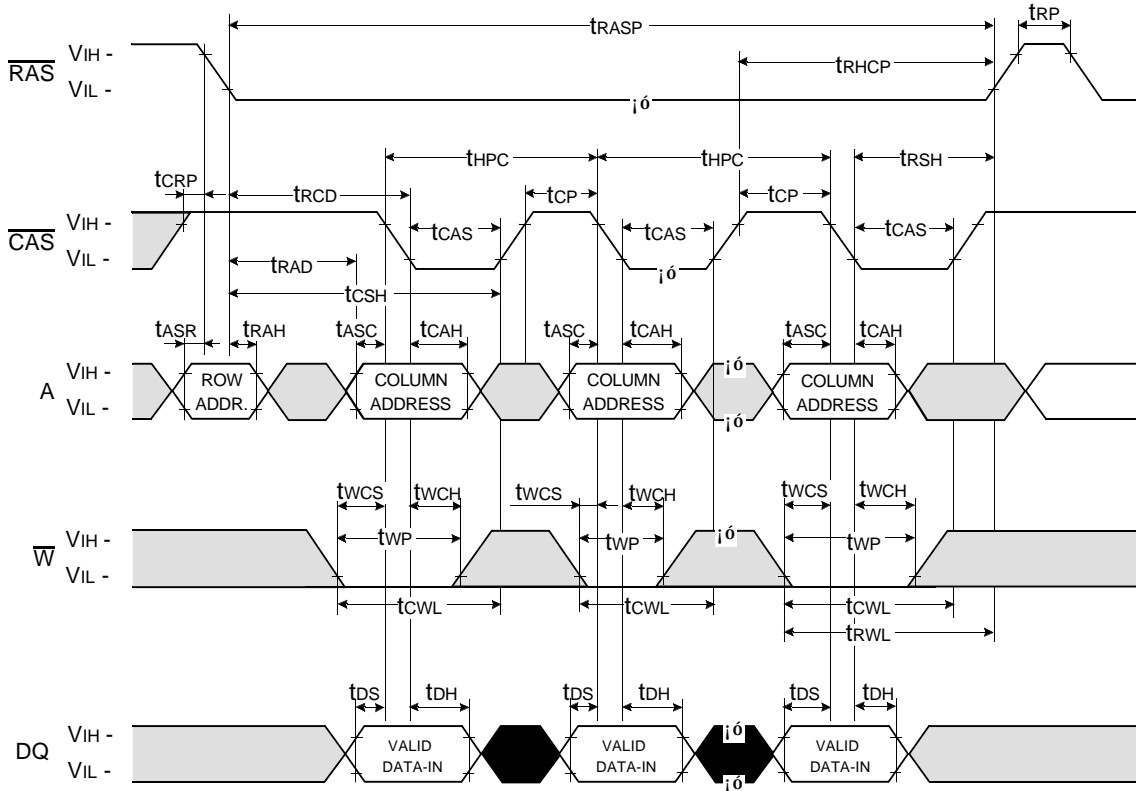

Don't care
 Undefined

$\overline{\text{RAS}}$ - ONLY REFRESH CYCLE*

NOTE : $\overline{\text{W}}$, $\overline{\text{OE}}$, DIN = Don't care

DOUT = OPEN

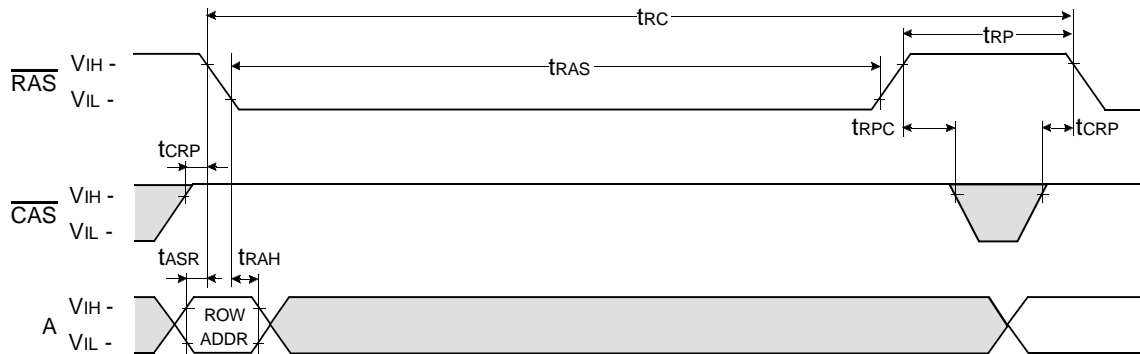

$\overline{\text{CAS}}$ - BEFORE - $\overline{\text{RAS}}$ REFRESH CYCLE

NOTE : $\overline{\text{OE}}$, A = Don't care

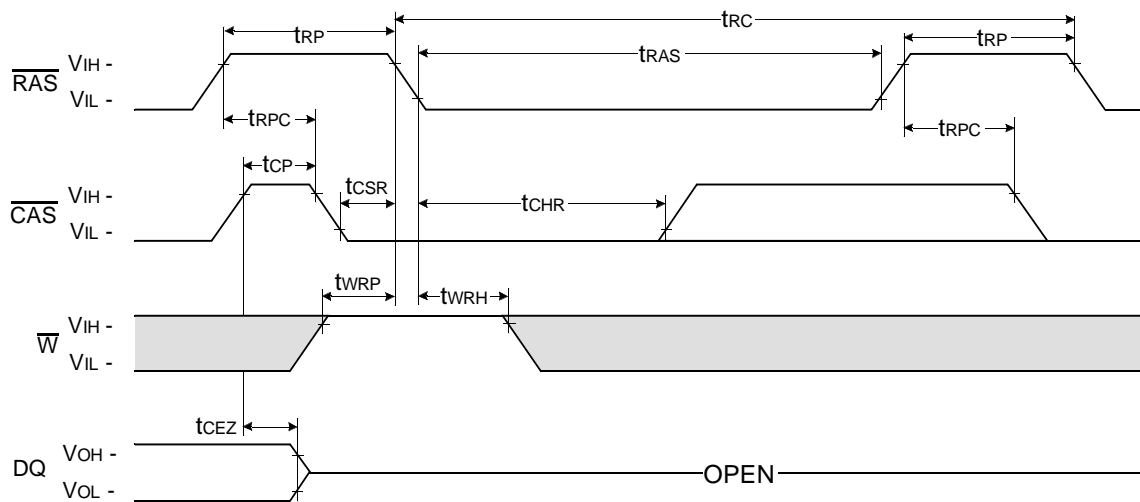

Don't care
 Undefined

* In RAS-only refresh cycle of 64Mb A-die & B-die, when $\overline{\text{CAS}}$ signal transits from Low to High, the valid data may be cut off.

HIDDEN REFRESH CYCLE (READ)

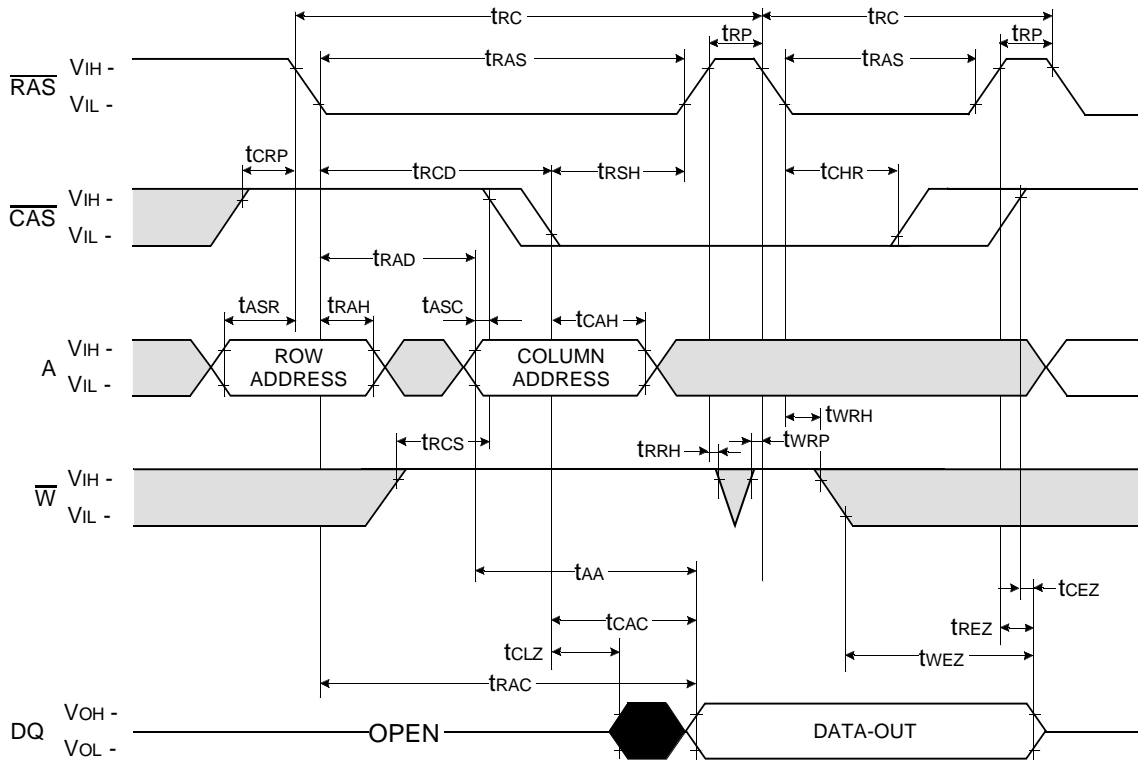

Don't care
 Undefined

HIDDEN REFRESH CYCLE (WRITE)

NOTE : DOUT = OPEN

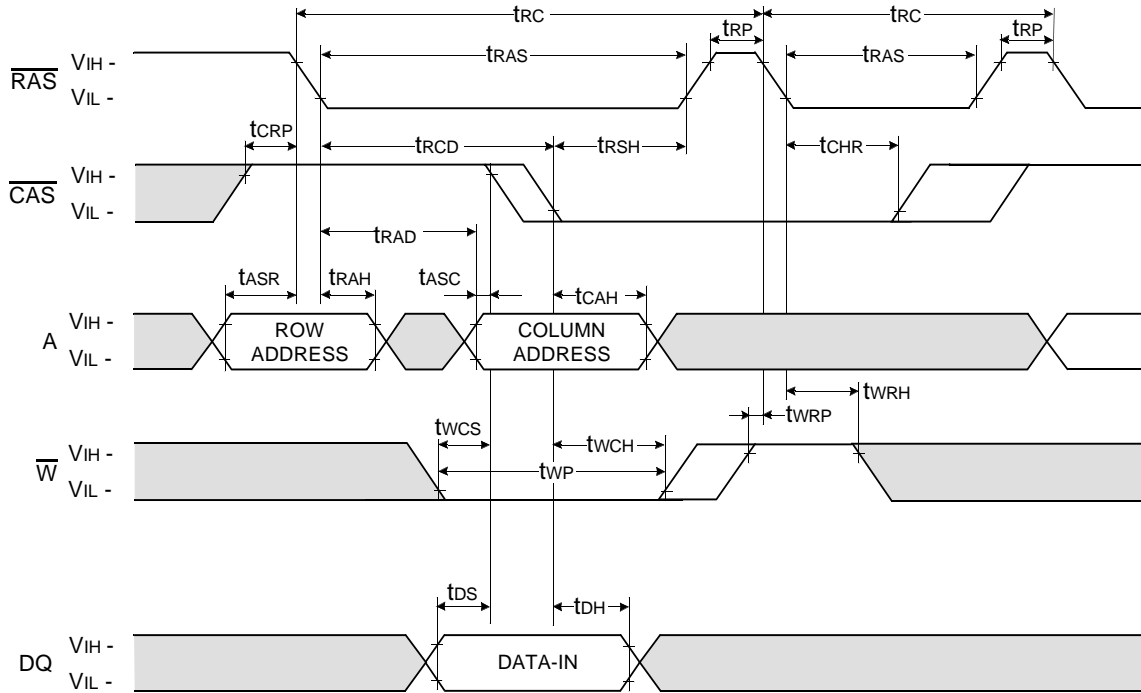

Don't care
 Undefined

CAS-BEFORE-RAS REFRESH COUNTER TEST CYCLE

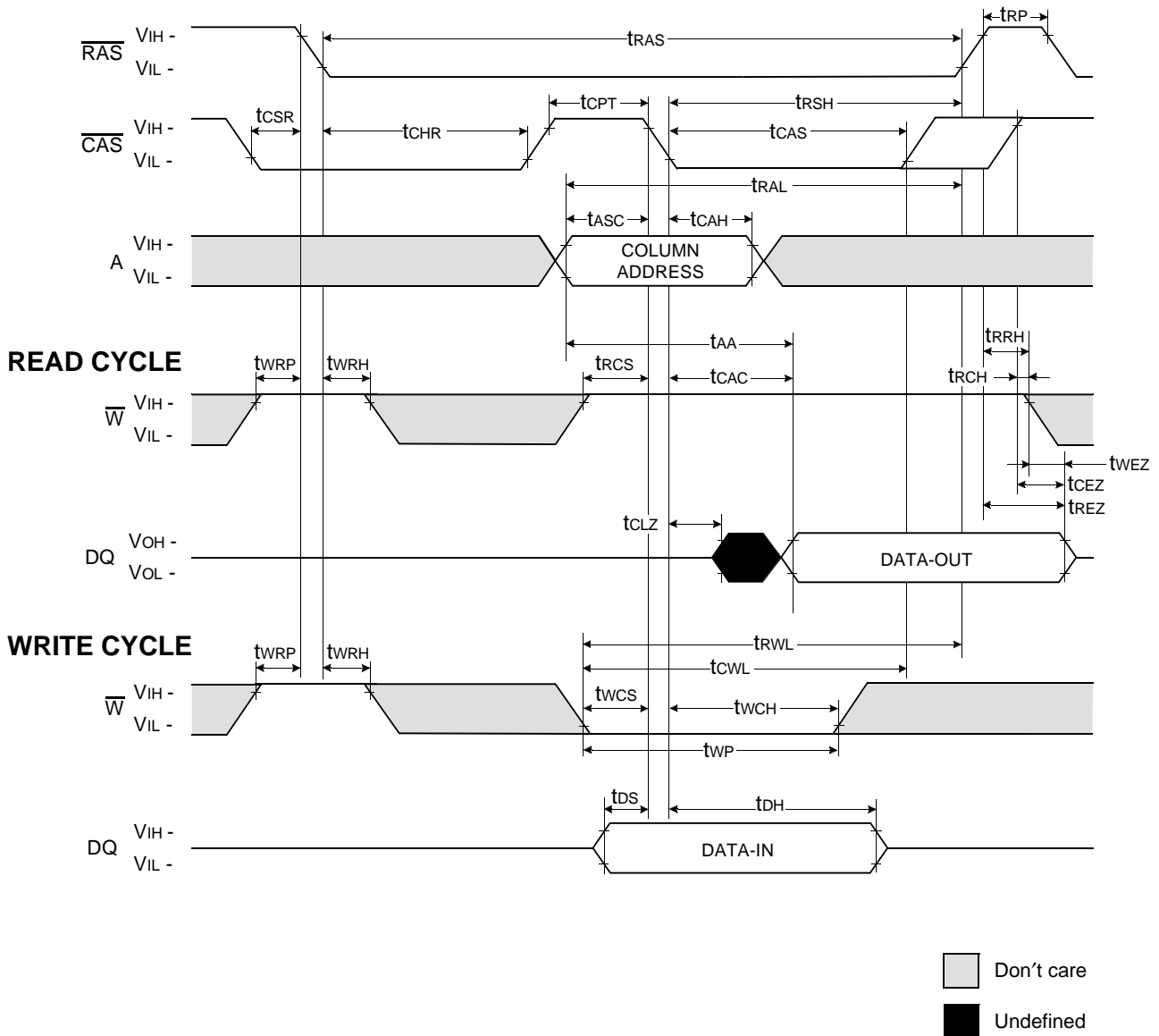

NOTE : This timing diagram is applied to all devices besides 64M DRAM based modules.

$\overline{\text{CAS}}$ - BEFORE - $\overline{\text{RAS}}$ SELF REFRESH CYCLE

NOTE : $\overline{\text{OE}}$, A = Don't care

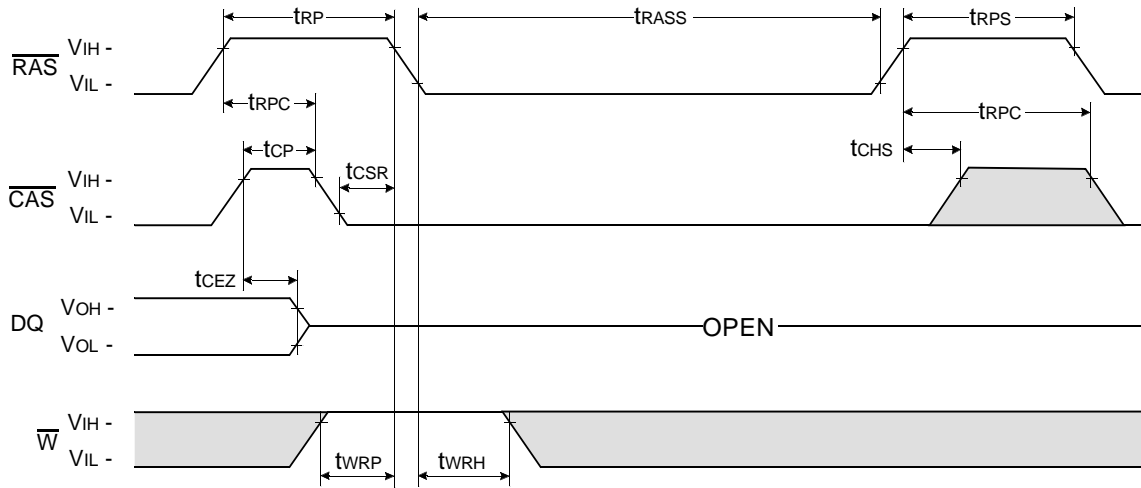

TEST MODE IN CYCLE

NOTE : $\overline{\text{OE}}$, A = Don't care

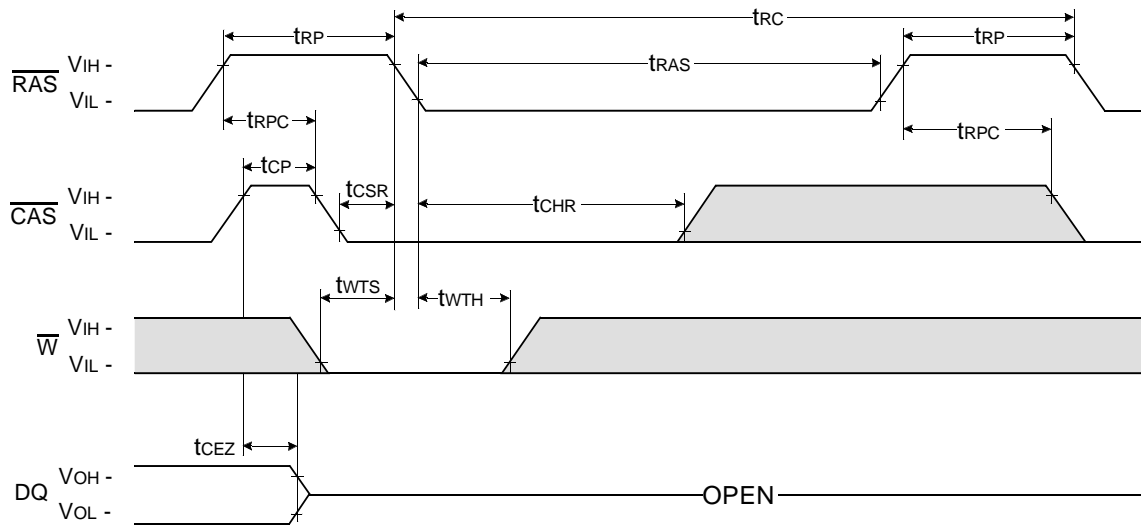

Don't care
 Undefined

DRAM MODULE

KMM5322204C2W/C2WG

PACKAGE DIMENSIONS

Units : Inches (millimeters)

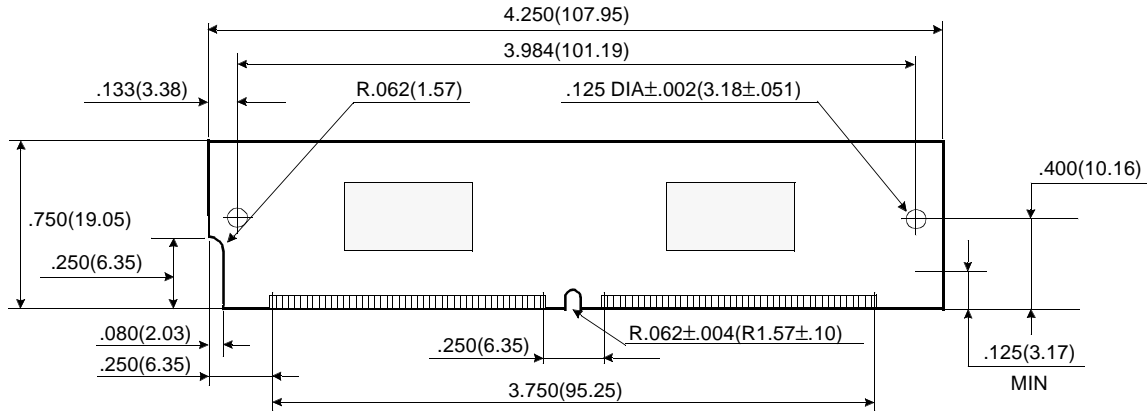

(Front view)

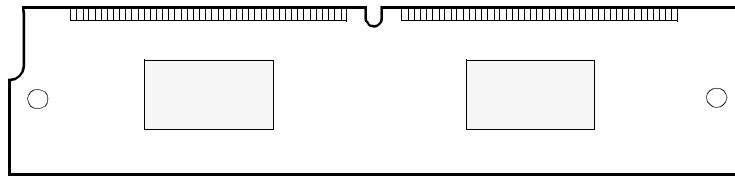

(Back view)

Gold & Solder Plating Lead

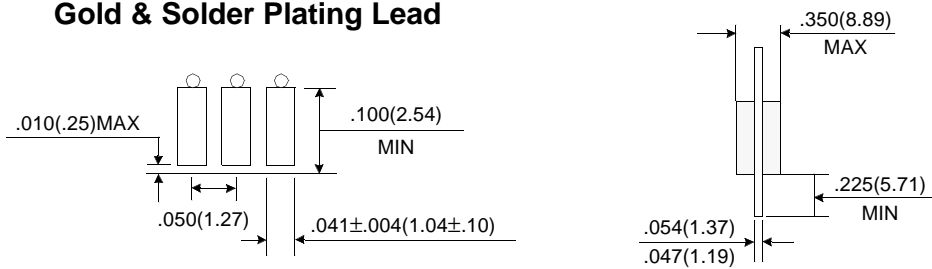

Tolerances : $\pm .005$ (.13) unless otherwise specified

NOTE : The used device is 1Mx16 DRAM
 DRAM Part No. : KMM5322204C2W/C2WG -- KM416C1204CJ (400 mil)

Revision History
 Rev 0.0 : Nov. 1997