

**1N3305 thru
1N3350B
and
1N4549B thru
1N4556B**

FEATURES

- ZENER VOLTAGE 3.9 TO 200V
- LOW ZENER IMPEDANCE
- HIGHLY RELIABLE AND RUGGED
- FOR MILITARY AND OTHER DEMANDING APPLICATIONS (See Below)

**SILICON
50 WATT
ZENER DIODES**

MAXIMUM RATINGS

Junction and Storage Temperatures: -65°C to $+175^{\circ}\text{C}$

DC Power Dissipation: 50 Watts

Power Derating: 0.5 W/ $^{\circ}$ above 75°C

Forward Voltage @ 10 A: 1.5 Volts

***ELECTRICAL CHARACTERISTICS @ 30°C Case Temperature**

JEDEC TYPE NO. (Note 1)	NOMINAL ZENER VOLTAGE V _Z @ I _Z (Note 2) Volts	ZENER TEST CURRENT I _Z (mA)	MAX. DYNAMIC IMPEDANCE (Note 3)		MAX. DC ZENER CURRENT I _Z (max) @ V _R (mA)	MAX. REVERSE LEAKAGE** CURRENT I _R (max) @ V _R (μ A)		TYPICAL TEMP. COEFF. α_{VZ} %/°C
			Z _{0k} @ I _Z OHMS	Z _{2k} @ I _Z I _{Zk} = 5mA OHMS		μ A	VOLTS	
+1N4549B	3.9	3200	0.16	400	11,900	150	0.5	-0.046
+1N4550B	4.3	2,900	0.16	500	10,650	150	0.5	-0.033
+1N4551B	4.7	2,650	0.12	600	9,700	100	1.0	-0.015
+1N4552B	5.1	2,450	0.12	650	8,900	20	1.0	± 0.010
+1N4553B	5.6	2,250	0.12	900	8,100	20	1.0	+0.030
+1N4554B	6.2	2,000	0.14	1,000	7,300	20	2.0	+0.049
+1N4555B	6.8	1,850	0.16	100	6,650	10	2.0	+0.053
+1N4556B	7.5	1,650	0.24	100	6,050	10	3.0	+0.057
+1N3305B	6.8	1,850	0.20	70	6,600	300	4.5	0.040
+1N3306B	7.5	1,700	0.30	70	5,900	125	5.0	0.046
+1N3307B	8.2	1,500	0.40	70	5,200	50	5.4	0.048
+1N3308B	9.1	1,370	0.50	70	4,800	25	6.1	0.060
+1N3309B	10.0	1,200	0.60	80	4,300	25	6.7	0.065
+1N3310B	11.0	1,100	0.80	80	3,900	10	8.4	0.060
+1N3311B	12.0	1,000	1.00	80	3,800	10	9.1	0.065
+1N3312B	13.0	960	1.10	80	3,300	10	9.9	0.065
+1N3313B	14.0	890	1.20	80	3,000	10	11.4	0.070
+1N3314B	15.0	830	1.40	80	2,800	10	11.4	0.070
+1N3315B	16.0	780	1.60	80	2,650	10	12.2	0.070
+1N3316B	17.0	740	1.80	80	2,500	10	13.0	0.076
+1N3317B	18.0	700	2.00	80	2,300	10	13.7	0.076
+1N3318B	19.0	660	2.20	80	2,200	10	13.7	0.076
+1N3319B	20.0	630	2.40	80	2,100	10	15.2	0.076
+1N3320B	22.0	570	2.50	80	1,900	10	16.7	0.080
+1N3321B	24.0	520	2.60	80	1,750	10	18.2	0.080
+1N3322B	25.0	500	2.70	90	1,550	10	18.2	0.080
+1N3323B	27.0	460	2.80	90	1,500	10	20.6	0.085
+1N3324B	30.0	420	3.00	90	1,400	10	22.8	0.085
+1N3325B	33.0	380	3.20	90	1,300	10	25.1	0.085
+1N3326B	36.0	350	3.50	90	1,150	10	27.4	0.085
+1N3327B	39.0	320	4.00	90	1,050	10	29.7	0.090
+1N3328B	43.0	290	4.50	90	975	10	32.7	0.090
+1N3329B	45.0	290	4.50	100	930	10	32.7	0.090
+1N3330B	47.0	270	5.00	100	880	10	35.8	0.090
+1N3331B	50.0	250	5.00	100	830	10	38.8	0.090
+1N3332B	51.0	245	5.20	100	810	10	38.8	0.090
+1N3333B	52.0	240	5.50	100	790	10	42.6	0.090
+1N3334B	56.0	220	6.00	110	740	10	42.6	0.090
+1N3335B	62.0	200	7.00	120	660	10	47.1	0.090
+1N3336B	68.0	180	8.00	140	600	10	51.7	0.090
+1N3337B	75.0	170	9.00	150	540	10	56.0	0.090
+1N3338B	82.0	150	11.00	160	490	10	62.2	0.090
+1N3339B	91.0	140	15.00	180	420	10	69.2	0.090
+1N3340B	100.0	120	20.00	200	400	10	76.0	0.090
+1N3341B	106.0	110	25.00	210	380	10	83.0	0.095
+1N3342B	110.0	110	30.00	220	365	10	83.0	0.096
+1N3343B	120.0	100	40.00	240	336	10	91.2	0.095
+1N3344B	130.0	95	50.00	275	310	10	99.8	0.096
+1N3345B	140.0	90	60.00	325	290	10	114.0	0.095
+1N3346B	150.0	85	75.00	400	270	10	114.0	0.095
+1N3347B	160.0	80	80.00	450	250	10	121.6	0.095
+1N3348B	175.0	70	85.00	500	230	10	121.6	0.095
+1N3349B	180.0	68	90.00	525	220	10	136.8	0.095
+1N3350B	200.0	65	100.00	600	200	10	152.0	0.100

* JEDEC Registered Data.

**Not JEDEC Data.

† Have JAN and JANTX and TXV Qualifications to MIL-S-19500/358.

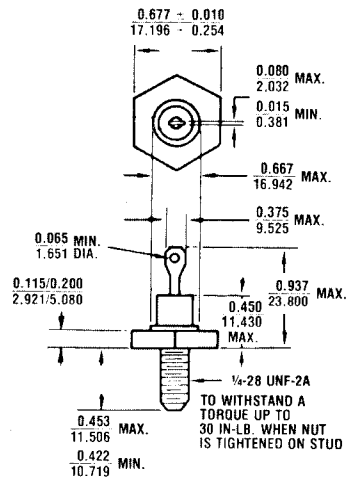

FIGURE 1

All dimensions in INCH
m. m.

MECHANICAL CHARACTERISTICS

CASE: Industry Standard DO-5, 11/16" Hex. stud with 1/4-28 threads, welded, hermetically sealed metal and glass.

DIMENSIONS: See outline drawing Fig. 1.

FINISH: All external surfaces are corrosion resistant and terminal solderable.

THERMAL RESISTANCE: 1.5°C/W (Typical) junction to stud.

POLARITY: Standard polarity anode to case. Reverse polarity (cathode to case) indicated by suffix R.

MOUNTING HARDWARE: See page 2-9.

1N3305 thru 1N3350B, 1N4549B thru 1N4556B

NOTE 1

When using JEDEC numbers an R suffix should be used to signify reversed polarity. The suffixes A and B indicate tolerances of 10% and 5% respectively. No suffix or just R denotes $\pm 20\%$ tolerance. Example: 1N3319RB is a REVERSED polarity, 20 volt unit having a $\pm 5\%$ tolerance on Zener Voltage.

NOTE 2

Zener Voltage (V_z) is measured with junction in thermal equilibrium with 30°C stud temperature.

NOTE 3

The zener impedance is derived from the 60 cycle A.C. voltage, which results when an A.C. current having an R.M.S. value equal to 10% of the D.C. zener current (I_{zt} or I_{zk}) is superimposed on I_{zt} or I_{zk} . Zener impedance is measured at 2 points to insure a sharp knee on the breakdown curve and to eliminate unstable units. A curve showing the variation of zener impedance vs. zener current for three representative types is shown in Figure 3.

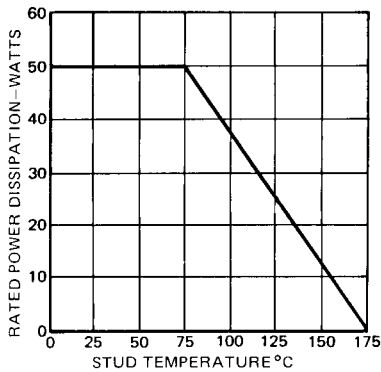

FIGURE 2
POWER DERATING CURVE

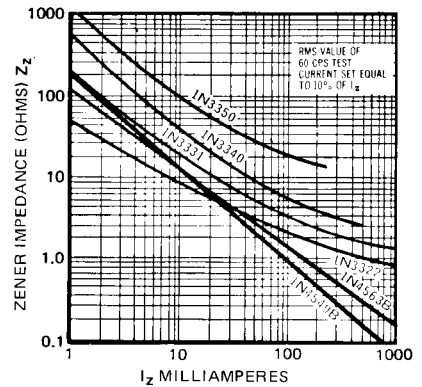

FIGURE 3
TYPICAL ZENER IMPEDANCE
vs. ZENER CURRENT