

# ACT4438-1

## Transceiver for MIL-STD-1553 / 1760

### in a Chipscale Package

*Preliminary*



### Features

- Transceiver meets military data bus requirements, MIL-STD-1553 and MIL-STD-1760
- Low power dissipation at full output power
- Single +5V power supply
- Current Source Transmitter Output
- Bipolar Monolithic Construction
- Miniature Chipscale Package Bumped Chip Carrier™ (BCC++)

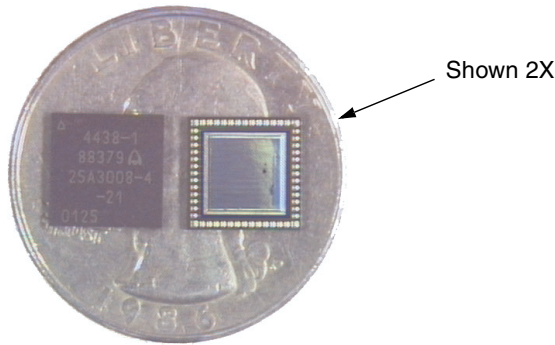

NOTE: BCC++ and Bumped Chip Carrier are Trademarks of Fujitsu Ltd.

### General Description

The Aeroflex Circuit Technology Model ACT4438-1 is a next generation monolithic transceiver which provide full compliance with MIL-STD-1553/1760 and data bus requirements in a Bumped Chip Carrier™ (BCC++) with the lowest standby power consumption and single power supply operation.

The Model ACT4438-1 performs the front-end analog function of inputting and outputting data through a transformer to a MIL-STD-1553/1760 data bus with a few external components.

Design of these transceivers reflects particular attention to active filter performance. This results in low bit and word error rate with superior waveform purity and minimal zero crossover distortion. Efficient transmitter electrical and thermal design provides low internal power dissipation and heat rise at high as well as low duty cycles.

### Transmitter

The Transmitter section accepts bi-phase TTL data at the input and when coupled to the data bus with a 1:2.5 transformer, isolated on the data bus side with two 55 Ohm fault isolation resistors for direct stub coupling. The data bus signal produced for RISET = 2.7K Ohm is typically 7.5 Volts nominal P-P at A-A', See Figure 5. When both DATA and DATA inputs are held low, the transmitter output becomes a high impedance and is "removed" from the line. In addition, an overriding "INHIBIT" input provides for the removal of the transmitter output from the line. A logic "1" applied to the "INHIBIT" takes priority over the

Block Diagram (without Transformer)

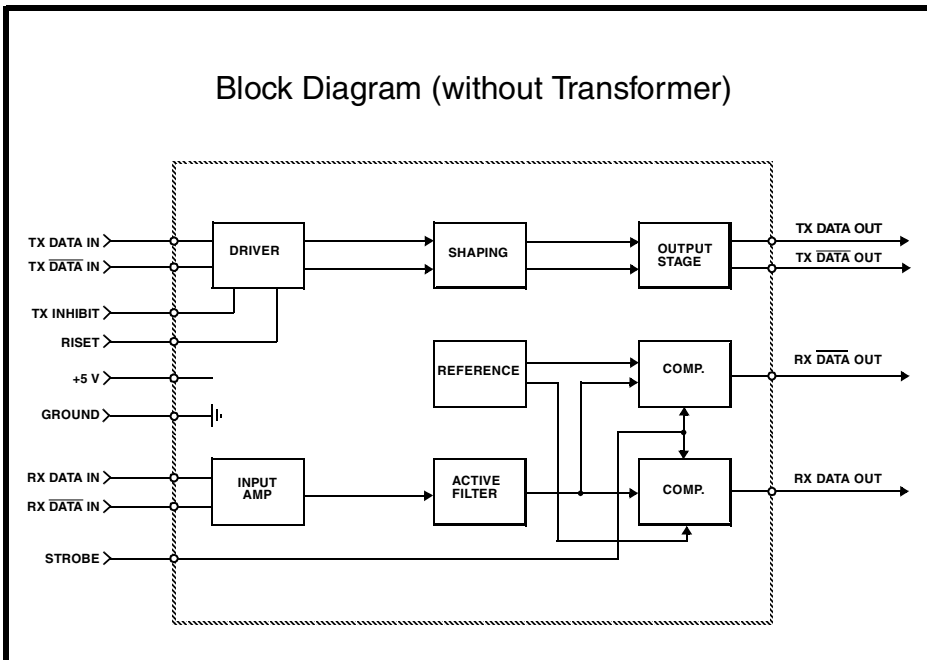

condition of the data inputs and disables the transmitter. (See Transmitter Logic Waveform, Figure 1.)

The transceiver utilizes an active filter to suppress harmonics above 1MHz. The Transmitter may be safely operated at 100% duty cycle for an indefinite period into a short circuited 1553 bus.

### Receiver

The Receiver section accepts bi-phase differential data at the input and produces two TTL signals at the output. The outputs are DATA and  $\overline{\text{DATA}}$ , and represent positive and negative excursions of the input beyond a pre-determined threshold. (See Receiver Logic Waveform, Figure 2.)

The pre-set internal thresholds will detect data bus signals exceeding 1.150 Volts P-P and reject signals less than 0.6 volts P-P when used with a 1:2.5 turns ratio transformer. (See Figure 5 for transformer data and typical connection.)

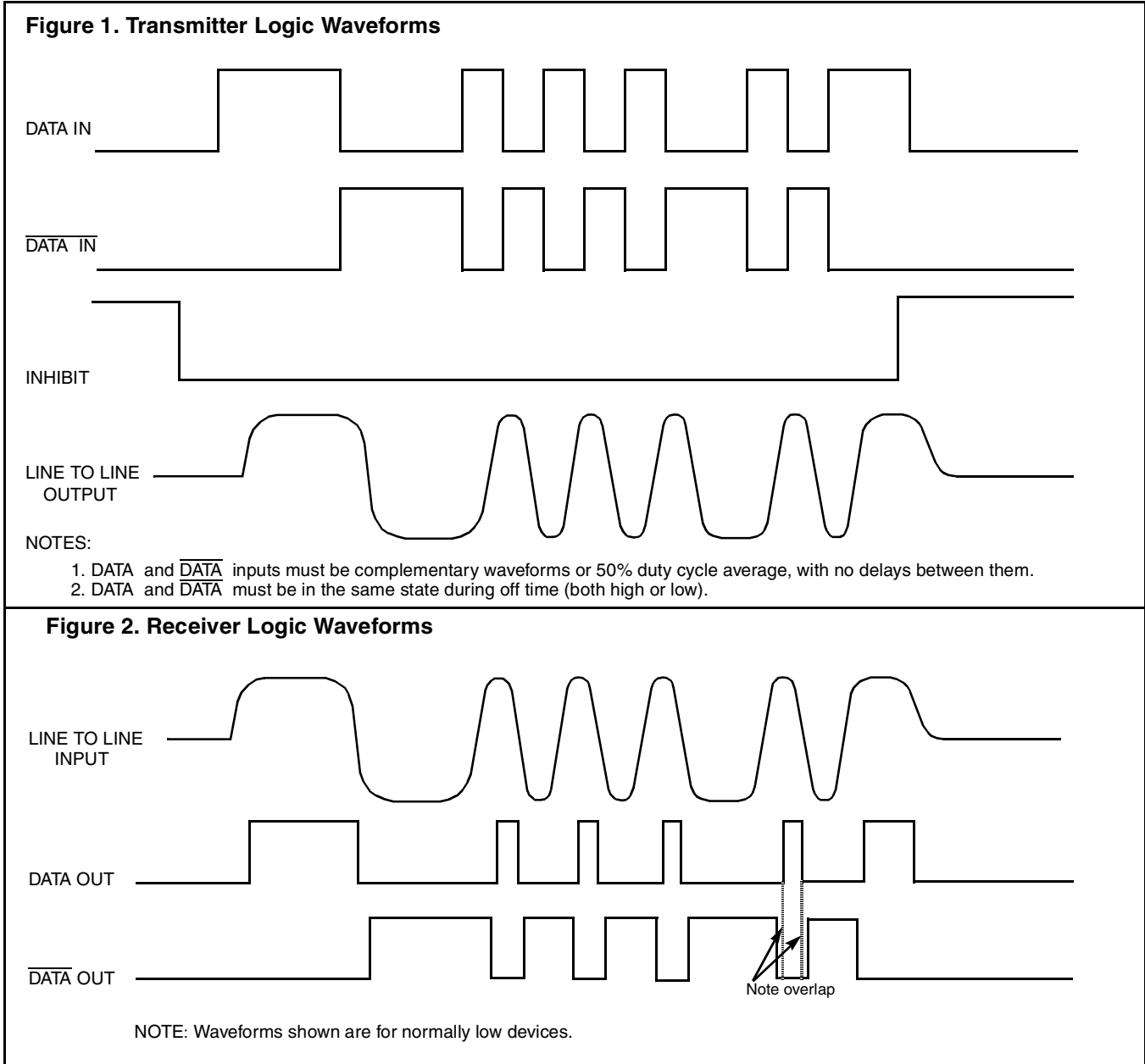

## Absolute Maximum Ratings

Operating Case Temperature	-55°C to +90°C
Storage Case Temperature	-65°C to +150°C
Positive Power Supply Voltage	-0.3 V to +7.0 V
Receiver Differential Input	±10 V
Receiver Input Voltage (Common Mode)	±5 V
Driver Peak Output Current	650 mA
Total Package Power Dissipation over the full operating case temperature rise at 100% duty cycle	2.2 Watt
Maximum Junction to Case temperature rise	44°C
Thermal Resistance, Junction to bottom of case	20°C/W

## Electrical Characteristics – Driver Section

### Input Characteristics, TX DATA in or TX $\overline{\text{DATA}}$ in

Parameter	Condition	Symbol	Min	Typ	Max	Unit
"0" Input Current	$V_{IN} = 0.4 \text{ V}$	$I_{ILD}$	-	-0.2	-0.4	mA
"1" Input Current	$V_{IN} = 2.7 \text{ V}$	$I_{IHD}$	-	1	40	μA
"0" Input Voltage		$V_{IHD}$	-	-	0.7	V
"1" Input Voltage		$V_{IHD}$	2.0	-	-	V

### Inhibit Characteristics

"0" Input Current	$V_{IN} = 0.4 \text{ V}$	$I_{ILI}$	-	-0.2	-0.4	mA
"1" Input Current	$V_{IN} = 2.7 \text{ V}$	$I_{IHI}$	-	1.0	40	μA
"0" Input Voltage		$V_{ILI}$	-	-	0.7	V
"1" Input Voltage		$V_{IHI}$	2	-	-	V
Delay from TX inhibit, (0→1) to inhibited output		$t_{DXOFF}$	-	150	300	nS
Delay from TX inhibit, (1→0) to active output		$t_{DXON}$	-	150	300	nS
Differential Output Noise, inhibit mode		$V_{NOI}$	-	2	10	mV p-p
Differential Output Impedance (inhibited)	Note 1	$Z_{OI}$	2K	-	-	Ω

### Output Characteristics

Differential output level	$R_L = 35 \text{ } \Omega$	$V_O$	6.5	7.5	8.0	V p-p
Rise and Fall Times (10% to 90% of p-p output)		$t_r$	100	200	300	nS
Output Offset at point A-A' on Fig 5., 2.5 μS after midpoint crossing of the parity bit of the last word of a 660 μS message	$R_L = 35 \text{ } \Omega$	$V_{OS}$	-	-	±90	mV peak
Delay from 50% point of TX DATA or TX $\overline{\text{DATA}}$ input to zero crossing of differential signal		$t_{DTX}$	-	150	300	nS

Note 1. Power ON/OFF, measured from 75KHz to 1MHz at Point A-A. See Figure 5

## Electrical Characteristics – Receiver Section

Parameter	Condition	Symbol	Min	Typ	Max	Unit
Differential Voltage Range		$V_{IDR}$	-	-	20	V peak
Common Mode Rejection Ratio		CMRR	45	-	-	dB

### Strobe Characteristics (Logic "0" inhibits output) if not used, a 1K pullup to 5 V is recommended

"0" Input Current	$V_S = 0.4 V$	$I_{IL}$	-	-0.2	-0.4	mA
"1" Input Current	$V_S = 2.7V$	$I_{IH}$	-	1	+40	$\mu A$
"0" Input Voltage		$V_{IL}$	-	-	0.7	V
"1" Input Voltage		$V_{IH}$	2.0	-	-	V
Strobe Delay (turn-on)		$t_{SD(ON)}$	-	90	200	nS
Strobe Delay (turn-off)		$t_{SD(OFF)}$	-	90	200	nS

### Threshold Characteristics (Sinewave input )

Input Threshold Voltage (Referred to the bus)	100KHz-1MHz	$V_{TH}$	0.60	0.8	1.15	V p-p
---	-------------	----------	------	-----	------	-------

### Output Characteristics, RX DATA and $\overline{RX DATA}$

"1" State	$I_{OH} = -0.4 mA$	$V_{OH}$	2.5	3.7	-	V
"0" State	$I_{OL} = 4 mA$	$V_{OL}$	-	0.3	0.5	V
Delay, (average) from differential input zero crossings to RX DATA and $\overline{RX DATA}$ output 50% points		$t_{DRX}$	-	330	450	nS

## Power Data

### Maximum Currents, (+5V) For R<sub>ISET</sub> = 2.2 K $\Omega$

Duty Cycle	Typ	Max
Transmitter Standby	20 mA	30 mA
25% duty cycle	155 mA	185 mA
50% duty cycle	264 mA	335 mA
100% duty cycle	600 mA	650 mA

### Power Supply Voltage

+V	4.75 to 5.5 Volts
----	-------------------

Note 2.  $V_{cc} = 5 \text{ Volts} \pm 0.1 \text{ V}$ , for all measurements unless otherwise specified.

Note 3. Specifications apply over the case temperature range of  $-55^{\circ}\text{C}$  to  $+90^{\circ}\text{C}$  unless otherwise specified.

Note 4. All typical values are measured at  $+25^{\circ}\text{C}$ .

**Figure 3 – Transmitter (TX) Output Waveform**

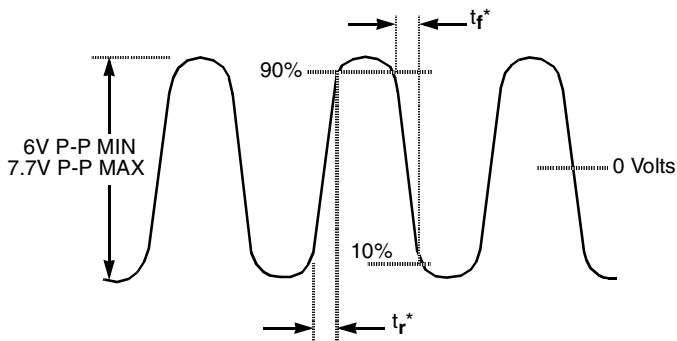

\* Rise and fall times measured at point A-A' in Fig 5

**Figure 4 – Transmitter (TX) Output Offset**

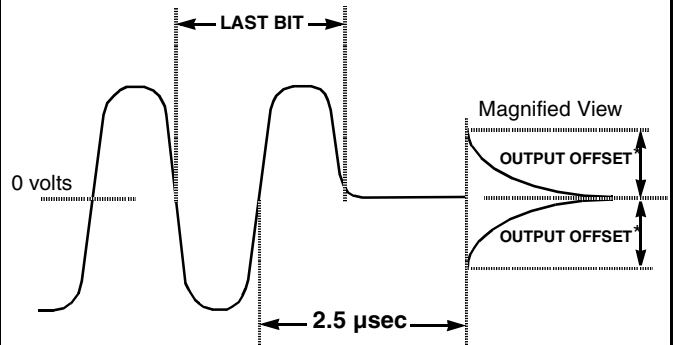

\*Offset measured at point A-A' in Fig 5

**Figure 5 – Typical Transformer Connection Direct Stub**

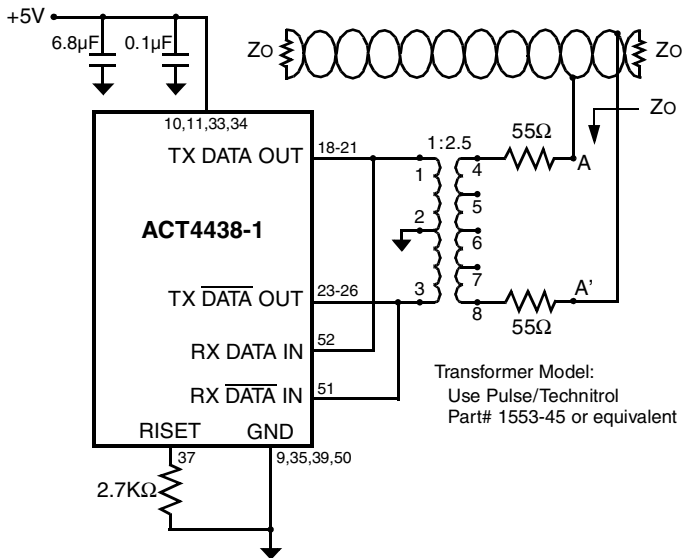

**Figure 6 – Power Dissipation vs. Duty Cycle**

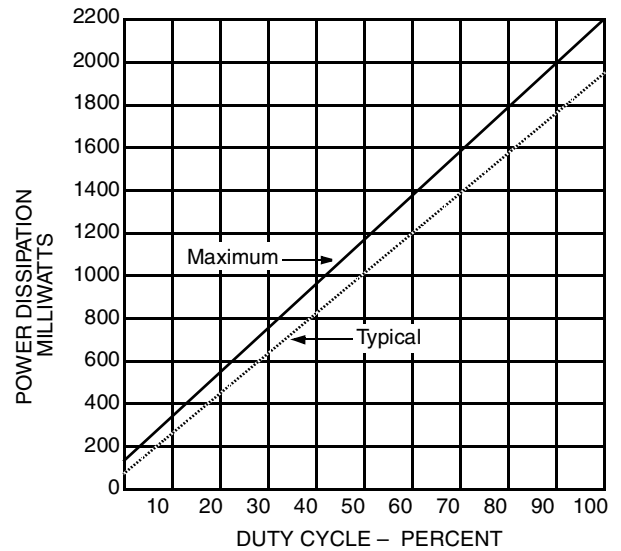

Note:  $V_{cc} = 5$  Volts,  $V_{bus}$  (pt A-A') at 7.5 Volts P-P

## Configurations and Ordering Information

Model No.	Screening Level	Receiver and Transmitter Data Levels (See Figure 1)	Case
ACT4438-1	Industrial Temperature -55°C to +90°C	Normally Low	56 Bump Chip Carrier

## Package Pin Out Description - ACT4438-1

Pin #	Function	Pin #	Function
1	NC	29	NC
2	NC	30	NC
3	NC	31	NC
4	NC	32	NC
5	V <sub>CC</sub>	33	V <sub>CC</sub> *
6	TX DATA IN	34	V <sub>CC</sub> *
7	TX $\overline{\text{DATA}}$ IN	35	GND
8	TX INHIBIT IN	36	NC
9	GND	37	RISET
10	V <sub>CC</sub> *	38	NC
11	V <sub>CC</sub> *	39	GND
12	NC	40	RX $\overline{\text{DATA}}$ OUT
13	NC	41	RX STROBE
14	NC	42	RX DATA OUT
15	NC	43	NC
16	NC	44	NC
17	NC	45	NC
18	TX DATA OUT *	46	NC
19	TX DATA OUT *	47	NC
20	TX DATA OUT *	48	NC
21	TX DATA OUT *	49	V <sub>CC</sub>
22	NC	50	GND
23	TX $\overline{\text{DATA}}$ OUT *	51	RX $\overline{\text{DATA}}$ IN
24	TX $\overline{\text{DATA}}$ OUT *	52	RX DATA IN
25	TX $\overline{\text{DATA}}$ OUT *	53	NC
26	TX $\overline{\text{DATA}}$ OUT *	54	NC
27	NC	55	NC
28	NC	56	NC

\* High current lines

## Package Description

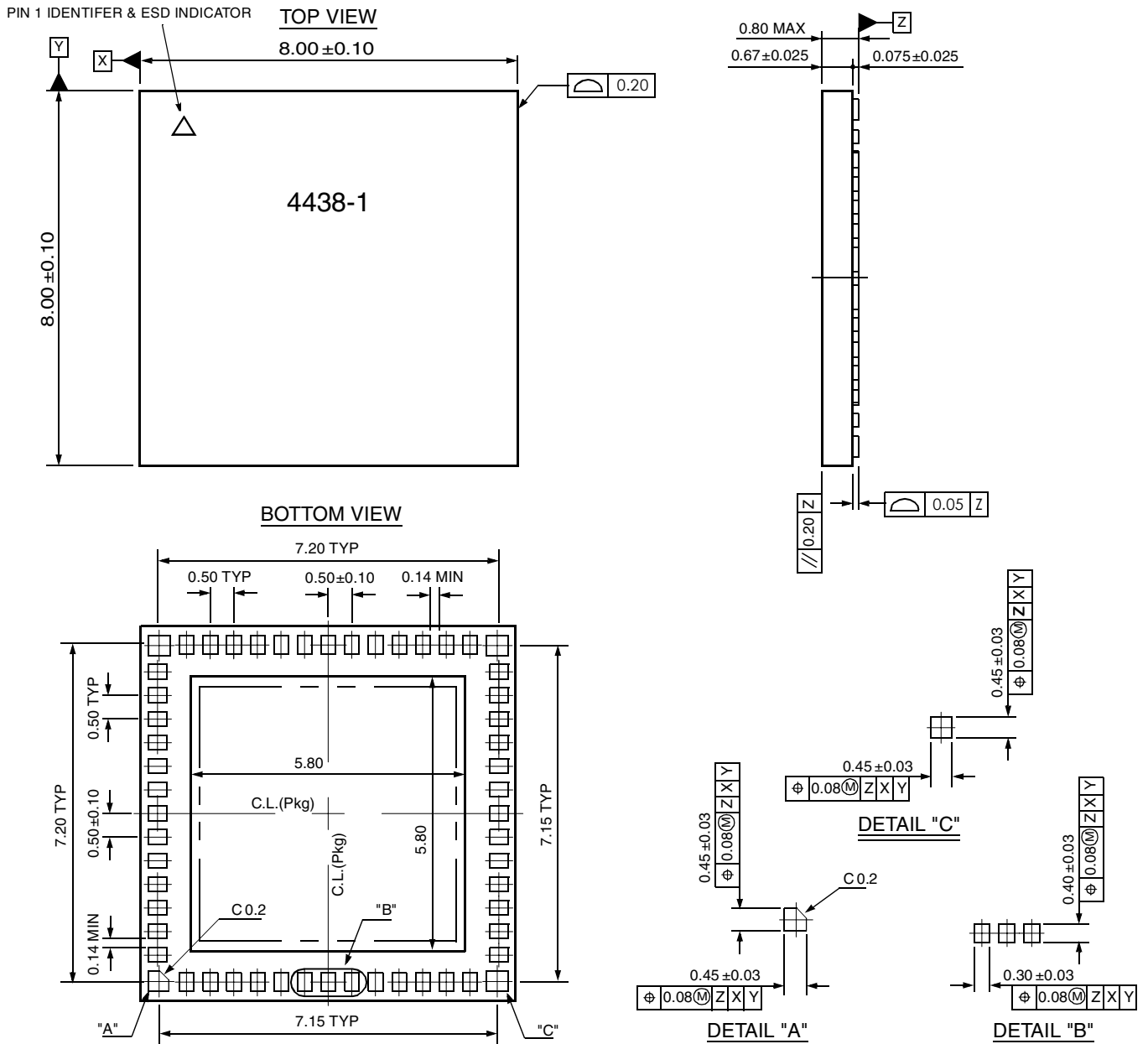

Notes  
1. Dimensions in millimeters

Specifications subject to change without notice.

**Aeroflex Circuit Technology**  
35 South Service Road  
Plainview New York 11803

**Telephone: (516) 694-6700**  
**FAX: (516) 694-6715**  
**Toll Free Inquiries: 1-(800) THE-1553**