

Philips Components

Document No.	853-0682
ECN No.	99799
Date of Issue	June 14, 1990
Status	Product Specification
ECL Products	

10180 Adder/Subtractor

Dual 2-Bit Adder/Subtractor

FEATURES

- Typical propagation delay: A_n, B_n to C_{OUT} 4.5ns
- Typical supply current ($-I_{EE}$): 70mA

DESCRIPTION

The 10180 is a high-speed, low power, general purpose adder/subtractor. Inputs for each adder are: Carry-in (C_{0IN}, C_{1IN}), Operand A (A_0, A_1), Operand B (B_0, B_1). Outputs are Sum (F_0, F_1), \overline{SUM} ($\overline{F_0}, \overline{F_1}$) and Carry-out (C_{0OUT}, C_{1OUT}). Common select inputs act as controlled lines to invert A or B for subtraction. A very high-speed operation is possible with Operand in the Sum or Carryout propagation delay of 4.5ns, and Carry-in to Carry-out propagation delay of 2.2ns. The 10180 is designed to be used in special purpose adder/subtractor or in high-speed multiplier arrays.

All unused inputs can be left open due to integrated pull-down resistors which avoid the need for a supply voltage.

ORDERING INFORMATION

DESCRIPTION	ORDER CODE
16-Pin Plastic DIP	10180N
16-Pin Ceramic DIP	10180F

PIN DESCRIPTION

PINS	DESCRIPTION
A_0, A_1	A Operand Inputs
B_0, B_1	B Operand Inputs
S_0, S_1	Select Inputs
C_{0IN}, C_{1IN}	Carry-in Inputs
C_{0OUT}, C_{1OUT}	Carry-out Outputs
$F_0, \overline{F_0}, F_1, \overline{F_1}$	Sum Outputs

PIN CONFIGURATION

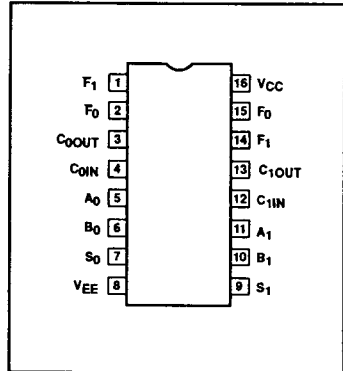

LOGIC DIAGRAM

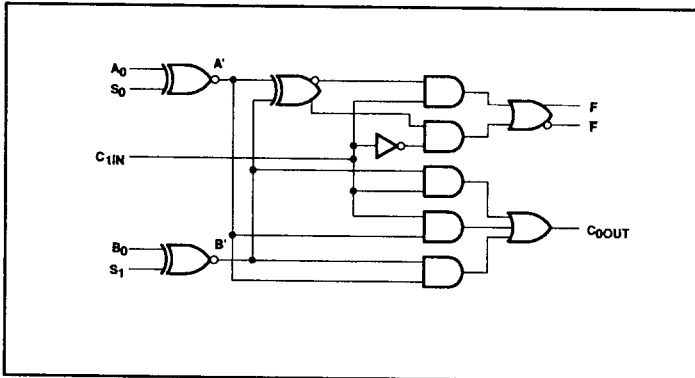

Adder/Subtractor

10180

FUNCTION SELECT TABLE

INPUTS		OUTPUTS
S ₀	S ₁	FUNCTIONS F
H	H	A + B + C _{IN}
H	L	C _{IN} + A - B
L	H	C _{IN} + B - A
L	L	C _{IN} - A - B

H = High Voltage Level

L = Low Voltage Level

 $A' = A \oplus S_0 = A \odot S_0$ $B' = B \oplus S_1 = B \odot S_1$

Both positive and negative logic:

 $F = C_{IN} (A' B' + A' B) + C_{IN} (A' B' + A' B')$ $C_{OUT} = C_{IN} A' + C_{IN} B' + A' B'$

FUNCTION TABLE

FUNCTION	INPUTS					OUTPUTS		
	S ₀	S ₁	A	B	C _{IN}	F	F	C _{OUT}
ADD (A + B + C ₁)	H	H	L	L	L	L	H	L
	H	H	L	L	H	L	L	L
	H	H	L	H	L	H	L	L
	H	H	L	H	H	H	H	H
	H	H	H	L	L	L	L	L
	H	H	H	L	H	L	L	L
	H	H	H	H	L	L	L	L
	H	H	H	H	H	H	H	H
SUBTRACT (C ₁ + A - B)	H	L	L	L	L	H	L	L
	H	L	L	L	H	L	H	L
	H	L	L	H	L	L	L	L
	H	L	L	H	H	L	L	L
	H	L	H	L	L	L	H	L
	H	L	H	L	H	L	H	L
	H	L	H	H	L	L	L	L
	H	L	H	H	H	L	L	L
Reverse SUBTRACT (C ₁ + B - A)	L	H	L	L	L	H	L	L
	L	H	L	L	H	L	H	L
	L	H	L	H	L	L	L	L
	L	H	L	H	H	L	L	L
	L	H	H	L	L	L	L	L
	L	H	H	L	L	L	L	L
	L	H	H	H	L	L	L	L
	L	H	H	H	H	L	L	L
(C ₁ - A - B)	L	L	L	L	L	L	H	H
	L	L	L	L	H	L	L	L
	L	L	L	H	L	L	L	L
	L	L	L	H	H	L	L	L
	L	L	H	L	L	L	L	L
	L	L	H	L	L	L	L	L
	L	L	H	H	L	L	L	L
	L	L	H	H	H	L	L	L

Adder/Subtractor**10180****ABSOLUTE MAXIMUM RATINGS**

SYMBOL	PARAMETER	LIMITS	UNIT	
V_{EE}	Supply voltage	-8.0	V	
V_{IN}	Input voltage (V_{IN} should never be more negative than V_{EE})	0 to V_{EE}	V	
I_O	Output source current (continuous)	-50	mA	
T_S	Storage temperature range	-55 to +150	°C	
T_J	Maximum junction temperature	Ceramic Package	+165	°C
		Plastic Package	+150	°C

NOTE:

Operation beyond the limits set forth in this table may impair the useful life of the device. Unless otherwise noted, these limits are specified over the operating ambient temperature range.

DC OPERATING CONDITIONS

SYMBOL	PARAMETER	TEST CONDITIONS	LIMITS			UNIT
			MIN.	NOM.	MAX.	
V_{CC}	Circuit ground		0	0	0	V
V_{EE}	Supply voltage (negative)			-5.2		V
V_{IH}	High level input voltage	$T_A = -30^\circ\text{C}$			-890	mV
		$T_A = +25^\circ\text{C}$			-810	mV
		$T_A = +85^\circ\text{C}$			-700	mV
V_{IHT}	High level input threshold voltage	$T_A = -30^\circ\text{C}$	-1205			mV
		$T_A = +25^\circ\text{C}$	-1105			mV
		$T_A = +85^\circ\text{C}$	-1035			mV
V_{ILT}	Low level input threshold voltage	$T_A = -30^\circ\text{C}$			-1500	mV
		$T_A = +25^\circ\text{C}$			-1475	mV
		$T_A = +85^\circ\text{C}$			-1440	mV
V_{IL}	Low level input voltage	$T_A = -30^\circ\text{C}$	-1890			mV
		$T_A = +25^\circ\text{C}$	-1850			mV
		$T_A = +85^\circ\text{C}$	-1825			mV
T_A	Operating ambient temperature range		-30	+25	+85	°C

NOTE:

When operating at other than the specified V_{EE} voltage (-5.2V), the DC and AC Electrical Characteristics will vary slightly from specified values.

Adder/Subtractor

10180

DC ELECTRICAL CHARACTERISTICS $V_{CC} = \text{ground}, V_{EE} = -5.2V \pm 0.010V, T_A = -30^\circ\text{C}$ to $+85^\circ\text{C}$ output loading with 50Ω to $-2.0V \pm 0.010V$ unless otherwise specified^{1,3}

SYMBOL	PARAMETER		TEST CONDITIONS ²		LIMITS			UNIT
					MIN.	TYP.	MAX.	
V_{OH}	High level output voltage		$T_A = -30^\circ\text{C}$	Using V_{IHMAX} and V_{ILMIN} , apply a functional pattern as indicated in the FUNCTION TABLE and measure V_{OH} on the respective outputs.	-1060		-890	mV
			$T_A = +25^\circ\text{C}$		-960		-810	mV
			$T_A = +85^\circ\text{C}$		-890		-700	mV
V_{OHT}	High level output threshold voltage		$T_A = -30^\circ\text{C}$	Apply V_{IHT} or V_{ILT} to one input at a time while applying V_{IHMAX} or V_{ILMIN} to all other inputs in accordance with the FUNCTION TABLE and measure V_{OHT} on the respective outputs.	-1080			mV
			$T_A = +25^\circ\text{C}$		-980			mV
			$T_A = +85^\circ\text{C}$		-910			mV
V_{OLT}	Low level output threshold voltage		$T_A = -30^\circ\text{C}$	Apply V_{ILT} or V_{IHT} to one input at a time while applying V_{IHMAX} or V_{ILMIN} to all other inputs in accordance with the FUNCTION TABLE and measure V_{OLT} on the respective outputs.			-1655	mV
			$T_A = +25^\circ\text{C}$				-1630	mV
			$T_A = +85^\circ\text{C}$				-1595	mV
V_{OL}	Low level output voltage		$T_A = -30^\circ\text{C}$	Using V_{IHMAX} and V_{ILMIN} , apply a functional pattern as indicated in the FUNCTION TABLE and measure V_{OL} on the respective outputs.	-1890		-1675	mV
			$T_A = +25^\circ\text{C}$		-1850		-1650	mV
			$T_A = +85^\circ\text{C}$		-1825		-1615	mV
I_{IH}	High level input current	C_{0IN}, C_{1IN} outputs	$T_A = -30^\circ\text{C}$	Apply V_{IHMAX} to each input under test, one at a time, with V_{ILMIN} applied to all other inputs.			590	μA
			$T_A = +25^\circ\text{C}$				370	μA
			$T_A = +85^\circ\text{C}$				370	μA
		A_0, A_1, B_0, B_1 inputs	$T_A = -30^\circ\text{C}$				350	μA
			$T_A = +25^\circ\text{C}$				220	μA
			$T_A = +85^\circ\text{C}$				220	μA
		S_0, S_1 inputs	$T_A = -30^\circ\text{C}$				460	μA
			$T_A = +25^\circ\text{C}$				290	μA
			$T_A = +85^\circ\text{C}$				290	μA
I_{IL}	Low level input current		$T_A = -30^\circ\text{C}$	Apply V_{ILMIN} to each input under test, one at a time, with V_{IHMAX} applied to all other inputs.	0.5			μA
			$T_A = +25^\circ\text{C}$		0.5			μA
			$T_A = +85^\circ\text{C}$		0.3			μA
$-I_{EE}$	V_{EE} supply current		$T_A = -30^\circ\text{C}$				95	mA
			$T_A = +25^\circ\text{C}$			70	86	mA
			$T_A = +85^\circ\text{C}$				95	mA
$\frac{\Delta V_{OH}}{\Delta V_{EE}}$	High level output voltage compensation		$T_A = +25^\circ\text{C}$			0.016		V/V
$\frac{\Delta V_{OL}}{\Delta V_{EE}}$	Low level output voltage compensation					0.250		V/V
$\frac{\Delta V_{BB}}{\Delta V_{EE}}$	Reference bias voltage compensation					0.148		V/V

NOTES:

- The specified limits represent the worst case values for the parameter. Since these worst case values normally occur at the supply voltage and temperature extremes, additional noise immunity can be achieved by decreasing the allowable operating condition ranges.
- Conditions for testing shown in the tables are not necessarily worst case. For worst case testing guidelines, refer to DC Testing, Chapter 1, Section 3.
- The specified limits shown in the DC Electrical Characteristics table can be met only after thermal equilibrium has been established. Thermal equilibrium is established by applying power for at least 2 minutes, while maintaining transverse airflow of 2.5 meters/sec (500 linear feet/min) over the device, mounted either in a test socket or on a printed circuit board. Test voltage values are given in the DC Operating Conditions table.

Adder/Subtractor

10180

AC ELECTRICAL CHARACTERISTICS $V_{CC} = \text{ground}, V_{EE} = -5.2V \pm 0.010V$

SYMBOL	PARAMETER	TEST CONDITIONS	LIMITS							UNIT
			$T_A = -30^\circ\text{C}$		$T_A = +25^\circ\text{C}$			$T_A = +85^\circ\text{C}$		
			MIN.	MAX.	MIN.	TYP.	MAX.	MIN.	MAX.	
t_{PLH} t_{PHL}	Propagation delay A_0, A_1, B_0, B_1 to F_0, F_1	Waveform 1	1.30	5.80	1.30	4.50	5.40	1.10	5.80	ns
t_{PLH} t_{PHL}	Propagation delay C_{0IN} to C_{0OUT}		1.30	5.80	1.30	4.50	5.40	1.10	5.80	ns
t_{PLH} t_{PHL}	Propagation delay S_0, S_1 to F_0, F_1		1.00	3.40	1.00	2.20	3.30	0.90	3.60	ns
t_{PLH} t_{PHL}	Propagation delay S_0, S_1 to F_0, F_1		1.00	3.40	1.00	2.20	3.30	0.90	3.60	ns
t_{TLH} t_{THL}	Transition time 20% to 80%, 80% to 20%		1.30	5.80	1.30	4.50	5.40	1.10	5.80	ns
t_{TLH} t_{THL}	Transition time 20% to 80%, 80% to 20%		1.00	3.80	1.10	2.40	3.70	1.10	3.90	ns

NOTE:

For AC test setup information, see AC Testing, Chapter 2, Section 3.

AC WAVEFORMS

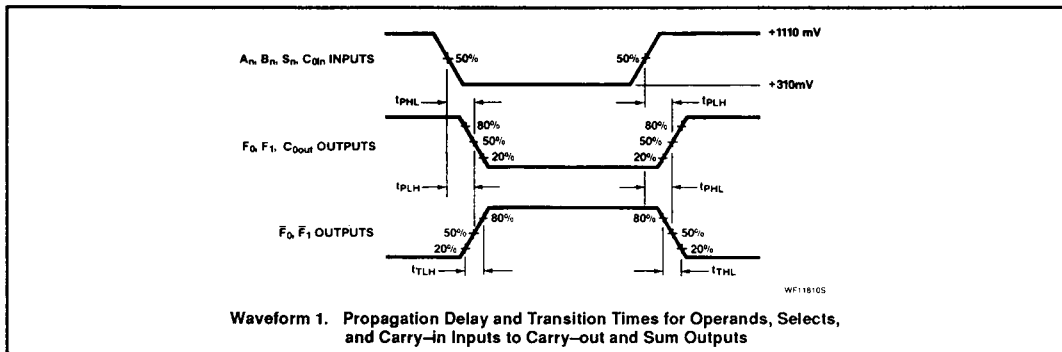

Waveform 1. Propagation Delay and Transition Times for Operands, Selects, and Carry-in Inputs to Carry-out and Sum Outputs