

## Programmable Watchdog Supervisory E<sup>2</sup>PROM

### FEATURES

- Programmable Watchdog Timer
- Low VCC Detection
- Reset Signal Valid to VCC = 1.0 Volt
- 1MHz Clock Rate
- 512 X 8 Bits Serial E<sup>2</sup>PROM
  - 4 Byte Page Mode
- Low Power CMOS
  - 150µA Standby Current
  - 5mA Active Current
- 2.7V To 5.5V Power Supply
- Block Lock™
  - Protect 1/4, 1/2 or all of E<sup>2</sup>PROM Array
- Built-in Inadvertent Write Protection
  - Power-Up/Power-Down protection circuitry
  - Write Latch
  - Write Protect Pin
- High Reliability
  - Endurance: 100,000 cycles per byte
  - Data Retention: 100 Years
  - ESD protection: 2000V on all pins
- 8-Pin Mini-DIP Package
- 8-Pin SOIC Package

### DESCRIPTION

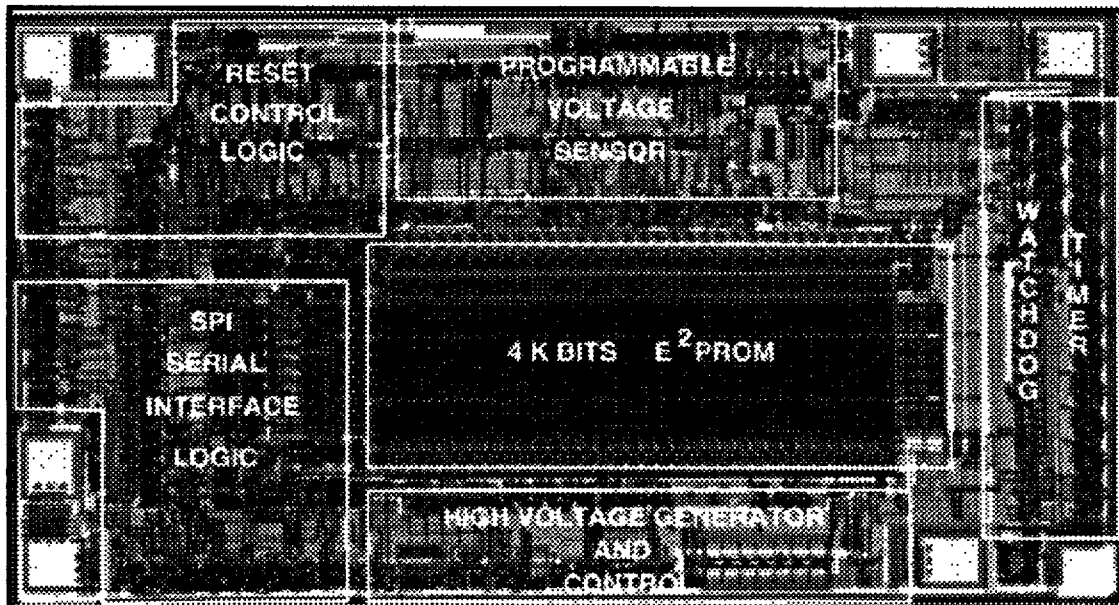
The X25043 is a CMOS 4096 bit serial E<sup>2</sup>PROM, internally organized as 512 x 8. The X25043 features a Serial Peripheral Interface (SPI) and software protocol allowing operation on a simple three wire bus. The bus signals are a clock input (SCK) plus separate data in (SI) and data out (SO) lines. Access to the device is controlled through a chip select (CS) input, allowing any number of devices to share the same bus.

The X25043 also features an additional input,  $\overline{WP}$  which is used as a hardware input to disable all write attempts thus providing a mechanism for limiting end user capability of altering the memory.

In addition the X25043 offers a  $\overline{RESET}$  output which provides a signal to the system whenever VCC drops below the minimum VCC trip point or  $\overline{CS}$  has remained either high or low longer than the watchdog time-out period.

The X25043 utilizes Xicor's proprietary Direct Write™ cell, providing a minimum endurance of 100,000 cycles per byte and a minimum data retention of 100 years.

### FUNCTIONAL DIAGRAM



Direct Write™ is a trademark of Xicor, Inc.

3844 FHD F01

©Xicor, 1994 Patents Pending

Characteristics subject to change without notice

3844-4 T2/C0/D1

■ 9941743 0005276 906 ■

# X25043

## PIN DESCRIPTIONS

### Serial Output (SO)

SO is a push-pull serial data output pin. During a read cycle, data is shifted out on this pin. Data is clocked out by the falling edge of the serial clock.

### Serial Input (SI)

SI is the serial data input pin. All opcodes, byte addresses, and data to be written to the memory are input on this pin. Data is latched by the rising edge of the serial clock.

### Serial Clock (SCK)

The Serial Clock controls the serial bus timing for data input and output. Opcodes, addresses, or data present on the SI pin are latched on the rising edge of the clock input, while data on the SO pin change after the falling edge of the clock input.

### Chip Select ( $\overline{CS}$ )

When  $\overline{CS}$  is high, the X25043 is deselected and the SO output pin is at high impedance and unless an internal write operation is underway the X25043 will be in the standby power mode.  $\overline{CS}$  low enables the X25043, placing it in the active power mode. It should be noted that after power-on, a high to low transition on  $\overline{CS}$  is required prior to the start of any operation.

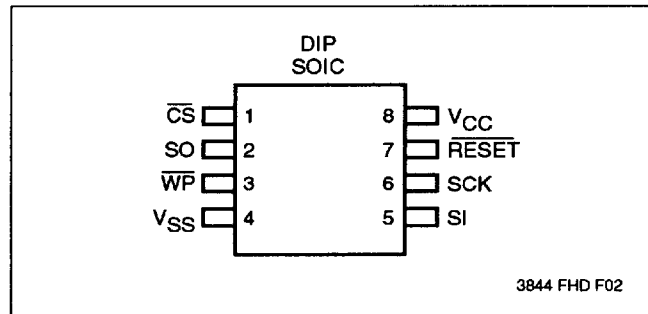
### Write Protect ( $\overline{WP}$ )

When  $\overline{WP}$  is low, nonvolatile writes to the X25043 are disabled, but the part otherwise functions normally. When  $\overline{WP}$  is held high, all functions, including nonvolatile writes operate normally.  $\overline{WP}$  going low while  $\overline{CS}$  is still low will interrupt a write to the X25043. If the internal write cycle has already been initiated,  $\overline{WP}$  going low will have no affect on write.

### Reset ( $\overline{RESET}$ )

$\overline{RESET}$  is an active low, open drain output which goes low whenever VCC falls below the minimum VCC sense level. It will remain low until VCC rises above the minimum VCC sense level for 200ms.  $\overline{RESET}$  also goes low if the Watchdog timer is enabled and  $\overline{CS}$  remains either high or low longer than the Watchdog time-out period. A falling edge of  $\overline{CS}$  will reset the watchdog timer.

## PIN CONFIGURATION



## PIN NAMES

Symbol	Description
$\overline{CS}$	Chip Select Input
SO	Serial Output
SI	Serial Input
SCK	Serial Clock Input
$\overline{WP}$	Write Protect Input
V <sub>SS</sub>	Ground
V <sub>CC</sub>	Supply Voltage
$\overline{RESET}$	Reset Output

3844 PGM T01

# X25043

## PRINCIPLES OF OPERATION

The X25043 is a 512 x 8 E<sup>2</sup>PROM designed to interface directly with the synchronous serial peripheral interface (SPI) of the popular 6805 and 68HC11 microcontroller families.

The X25043 contains an 8-bit instruction register. It is accessed via the SI input, with data being clocked in on the rising SCK. CS must be low and WP input must be high during the entire operation. The X25043 monitors the bus and provides a RESET output if there is no bus activity within the preset time period.

Table 1 contains a list of the instructions and their operation codes. All instructions, addresses and data are transferred MSB first. Bit 3 of the Read and Write instructions contain the higher order address bit, A<sub>8</sub>.

Data input is sampled on the first rising edge of SCK after CS goes low. SCK is static, allowing the user to stop the clock and then resume operations.

### Write Enable (WREN) and Write Disable (WRDI)

The X25043 contains a write enable latch. This latch must be SET before a write operation will be completed internally. The WREN instruction will set the latch and the WRDI instruction will reset the latch. This latch is automatically reset upon a power-on condition and after the completion of a byte, page or status register write cycle. The latch is also reset if WP is brought low.

### Read Status Register (RDSR)

The RDSR instruction provides access to the status register. The status register may be read at any time, even during a write cycle. The status register is formatted as follows:

7	6	5	4	3	2	1	0
X	X	WD1	WD0	BL1	BL0	WEL	WIP

The **Write-In-Process (WIP)** bit indicates whether the X25043 is busy with a write operation. When set to a "1" a write is in progress, when set to a "0" no write is in progress. During a write all other bits are set to "1". The WIP bit is read only.

The **Write Enable Latch (WEL)** bit indicates the status of the write enable latch. When set to a "1" the latch is set, when set to a "0" the latch is reset. The WEL bit is read only and is set by the WREN instruction and reset by WRDI instruction or successful completion of a write cycle.

The **Block Protect (BL0 and BL1)** bits indicate the extent of protection employed. These bits are set by the user issuing the WRSR instruction.

The **Watchdog Timer (WD0 and WD1)** bits allow setting of the watchdog time-out function as shown in the table. These bits are set by issuing the WRSR instruction.

### Write Status Register (WRSR)

The write status register instruction allows the user to select one of four levels of protection and program the watchdog timer. The X25043 is divided into four 1024-bit segments. One, two, or all four of the segments may be locked. That is, the user may read the segments but will be unable to alter (write) data within the selected segments. The partitioning is controlled as illustrated below with the state of BL1 and BL0.

Status Register Bits		Watchdog Time-out
WD1	WD0	
0	0	1.4 Seconds
0	1	600 Milliseconds
1	0	200 Milliseconds
1	1	Disabled

Status Register Bits		Array Addresses Protected
BL1	BL0	
0	0	None
0	1	\$180-\$1FF
1	0	\$100-\$1FF
1	1	\$000-\$1FF

# X25043

## DEVICE OPERATION

### Clock and Data Timing

Data input on the SI line is latched on the rising edge of SCK. Data is output on the SO line by the falling edge of SCK.

### Read Sequence

The  $\overline{CS}$  line is first pulled low to select the device. The 8 bit read instruction is transmitted to the X25043, followed by the 8 bit byte address. Bit 3 of the Read instruction contains address  $A_8$ . This bit is used to select the upper or lower half of the device. After the read opcode and byte address are sent, the data stored in the memory at the selected address is shifted out on the SO line. The data stored in memory at the next address can be read sequentially by continuing to provide clock pulses. The byte address is automatically incremented to the next higher address after each byte of data is shifted out. When the highest address is reached (\$1FF) the address counter rolls over to address \$000 allowing the read cycle to be continued indefinitely. The read operation is terminated by taking  $\overline{CS}$  high. Refer to the read operation sequence illustrated in Figure 1.

### Write Sequence

Prior to any attempt to write data into the X25043 the write enable latch must first be set by issuing the WREN instruction. (See Fig. 2)  $\overline{CS}$  is first taken low, then the instruction is clocked into the X25043. After all eight bits of the instruction are transmitted,  $\overline{CS}$  must then be taken high. If the user continues the write operation without taking  $\overline{CS}$  high after issuing the WREN instruction the write operation will be ignored.

Once the write enable latch is set, the user may proceed by issuing the write instruction, followed by the address and then the data to be written. Bit 3 of the Write instruction contains address  $A_8$ . This bit is used to select the upper or lower half of the device. This is minimally a twenty-four clock operation.  $\overline{CS}$  must go low and remain low for the duration of the operation. The host may continue to write up to four bytes of data to the X25043. The only restriction is the four bytes must reside on the same page. A page address begins with address X XXXX XX00 and ends with X XXXX XX11. If the byte address counter reaches X XXXX XX11 and the clock continues the counter will roll back to the first address of the page and overwrite any data that may have been written.

For the write operation (byte or page write) to be completed,  $\overline{CS}$  can only be brought high after the twenty-fourth, thirty-second, fortieth or fortyeighth clock. If it is brought high at any other time the write operation will not be completed. Refer to Figure 4 below for a detailed illustration of the page write sequence and time frames in which  $\overline{CS}$  going high are valid.

While the write is in progress the status register may be read to check the WIP bit. During this time the WIP bit will be high and all other bits in the status register will be undefined.

### RESET Operation

The  $\overline{RESET}$  output is designed to go low whenever  $V_{CC}$  has dropped below the minimum trip point and/or the Watchdog timer has reached its programmable time-out limit.

Table 1. Instruction Set

Instruction Name	Instruction Format*	Operation
WREN	0000 0110	Set the Write Enable Latch (Enable Write Operations)
WRDI	0000 0100	Reset the Write Enable Latch (Disable Write Operations)
RDSR	0000 0101	Read Status Register
WRSR	0000 0001	Write Status Register (Block Protect Bits)
READ	0000 A011	Read Data from Memory Array beginning at selected address
WRITE	0000 A010	Write Data to Memory Array beginning at Selected Address (1 to 4 Bytes)

\*Instructions are shown MSB in leftmost position. Instructions are transferred MSB first.

# X25043

## Operational Notes

The X25043 powers-on in the following state:

- The device is in the low power standby state.
- A high to low transition on  $\overline{CS}$  is required to enter an active state and receive an instruction.
- SO pin is high impedance.
- The write enable latch is reset.

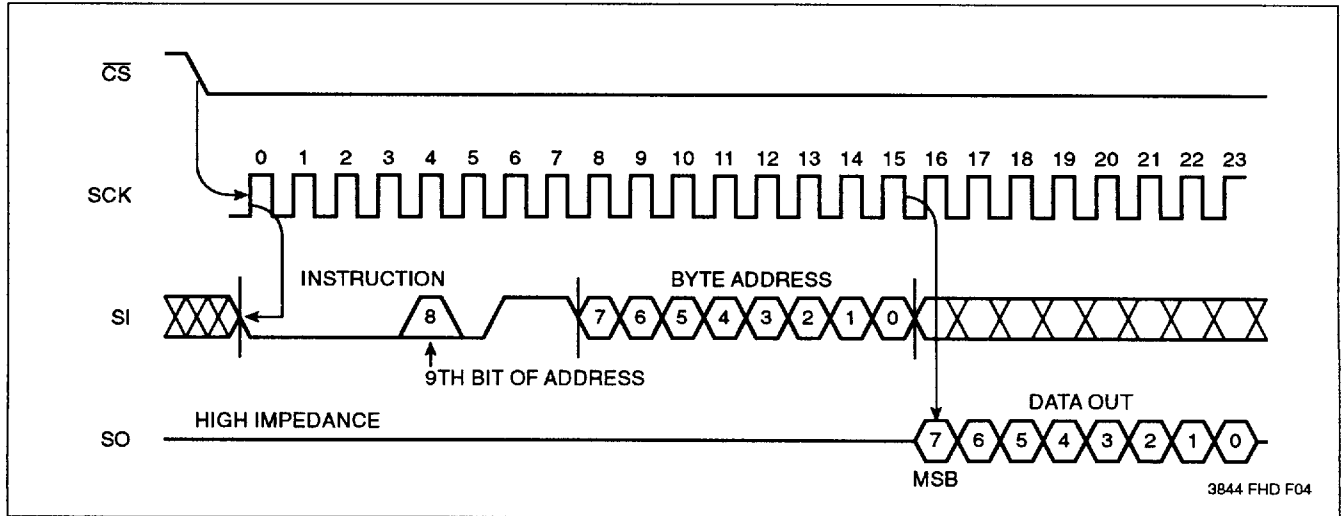
## Data Protection

The following circuitry has been included to prevent inadvertent writes:

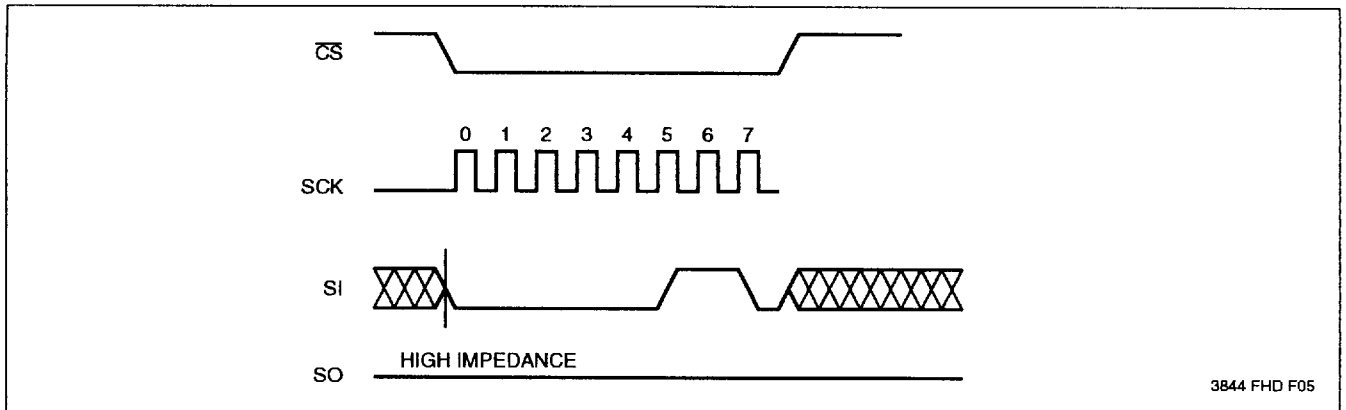
- The write enable latch is reset upon power-up.
- A write enable instruction must be issued to set the write enable latch.
- $\overline{CS}$  must come high at the proper clock count in order to start a write cycle.

The write enable latch is reset when  $\overline{WP}$  is brought low.

**Figure 1. Read Operation Sequence**

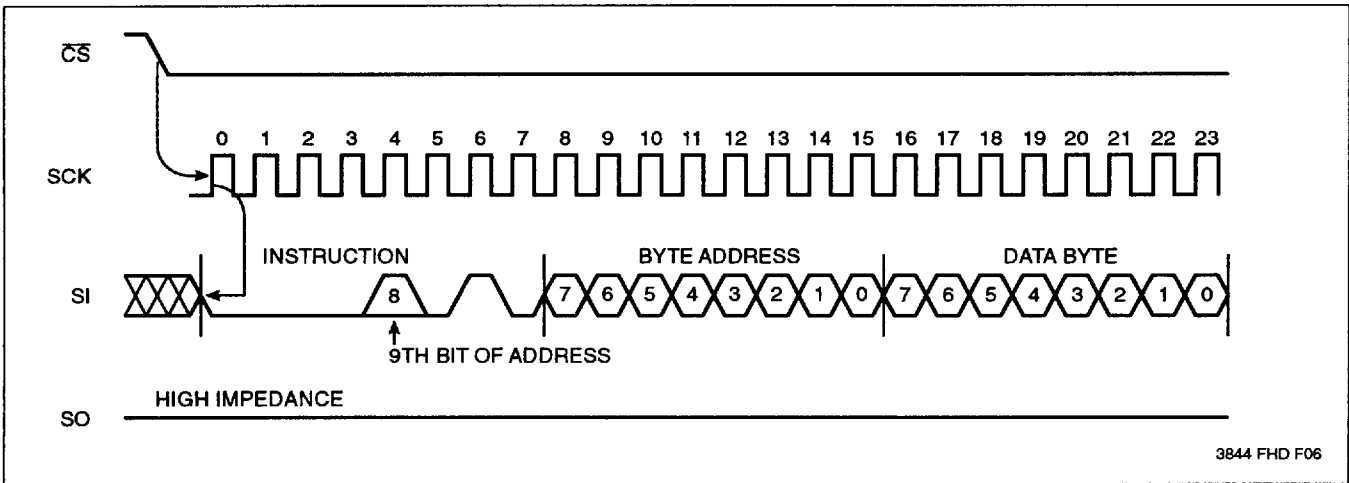


**Figure 2. Write Enable Latch**

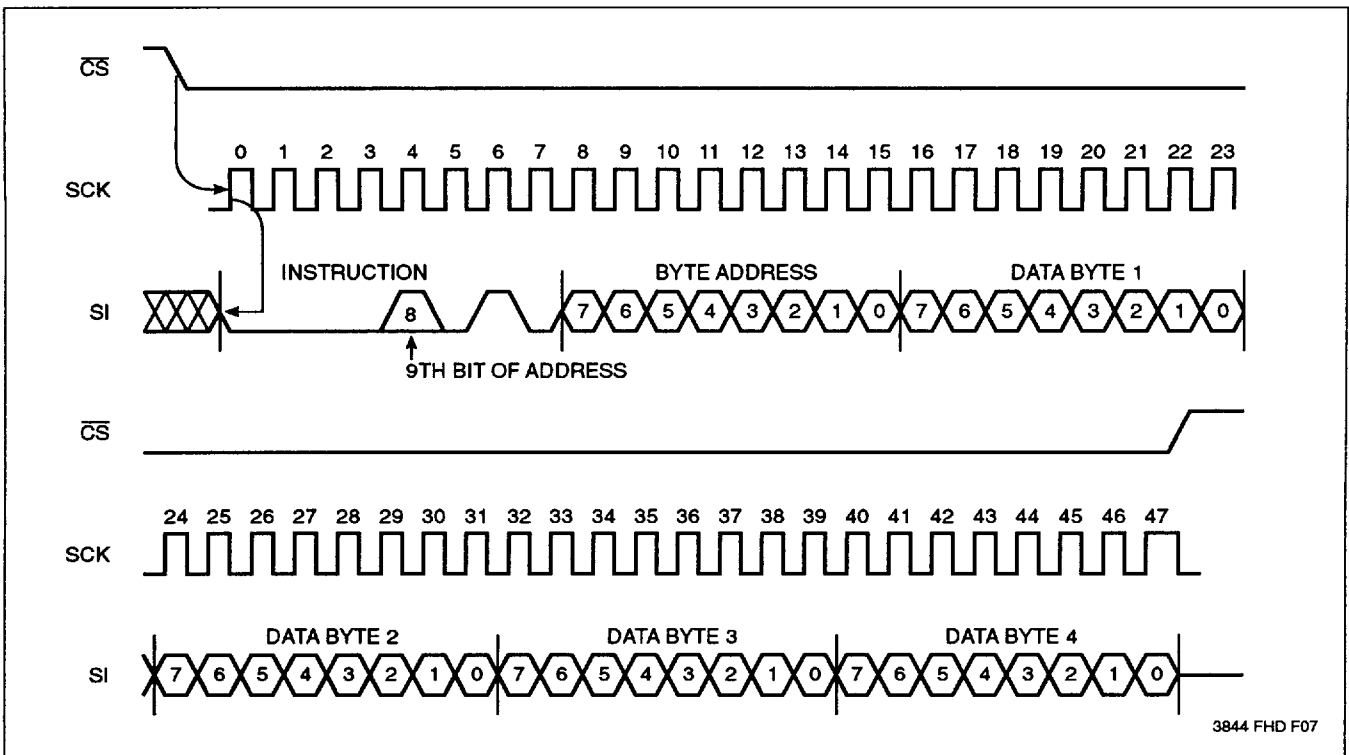


# X25043

**Figure 3. Write Operation Sequence**



**Figure 4. Page Write Operation Sequence**



# X25043

## ABSOLUTE MAXIMUM RATINGS\*

Temperature Under Bias .....	-65°C to +135°C
Storage Temperature .....	-65°C to +150°C
Voltage on any Pin with Respect to Ground	-1.0V to +7V
D.C. Output Current .....	5mA
Lead Temperature (Soldering, 10 Seconds) .....	300°C

## \*COMMENT

Stresses above those listed under "Absolute Maximum Ratings" may cause permanent damage to the device. This is a stress rating only and the functional operation of the device at these or any other conditions above those listed in the operational sections of this specification is not implied. Exposure to absolute maximum rating conditions for extended periods may affect device reliability.

## RECOMMENDED OPERATING CONDITIONS

Temp	Min.	Max.
Commercial	0°C	70°C
Industrial	-40°C	+85°C
Military	-55°C	+125°C

3844 PGM T03

Supply Voltage	Limits
X25043	5V ± 10%
X25043-2.7	2.7 to 5.5V
X25043-3	3.0 to 5.5

3844 PGM T04

## D.C. OPERATING CHARACTERISTICS (Over the recommended operating conditions unless otherwise specified.)

Symbol	Parameter	Limits		Units	Test Conditions
		Min.	Max.		
I <sub>CC</sub>	V <sub>CC</sub> Supply Current (Active)		3	mA	SCK = V <sub>CC</sub> x 0.1/V <sub>CC</sub> x 0.9 @ 1MHz, SO = OPEN
I <sub>SB1</sub>	V <sub>CC</sub> Standby Current		200	µA	$\overline{CS} = V_{CC}=5.5V, V_{IN} = Gnd \text{ or } V_{CC}$
I <sub>SB2</sub>	V <sub>CC</sub> Standby Current		150	µA	$\overline{CS} = V_{CC}=2.7V, V_{IN} = Gnd \text{ or } V_{CC}$
I <sub>LI</sub>	Input Leakage Current		10	µA	V <sub>IN</sub> = GND to V <sub>CC</sub>
I <sub>LO</sub>	Output Leakage Current		10	µA	V <sub>OUT</sub> = GND to V <sub>CC</sub>
V <sub>IL</sub> <sup>(1)</sup>	Input Low Voltage	-1.0	V <sub>CC</sub> x 0.3	V	
V <sub>IH</sub> <sup>(1)</sup>	Input High Voltage	V <sub>CC</sub> x 0.7	V <sub>CC</sub> + 0.5	V	
V <sub>OL</sub>	Output Low Voltage		0.4	V	I <sub>OL</sub> = 2mA
V <sub>OH1</sub>	Output High Voltage	V <sub>CC</sub> -0.8		V	I <sub>OH</sub> = -1.6mA, V <sub>CC</sub> =5V
V <sub>OH2</sub>	Output High Voltage	V <sub>CC</sub> -0.4		V	I <sub>OH</sub> = -.4mA, V <sub>CC</sub> =2.7V
V <sub>OLRS</sub>	Reset Output Low Voltage		0.4	V	I <sub>OL</sub> = 1mA

3844 PGM T05

## POWER-UP TIMING

Symbol	Parameter	Min.	Max.	Units
t <sub>PUR</sub> <sup>(2)</sup>	Power-up to Read Operation		1	ms
t <sub>PUW</sub> <sup>(2)</sup>	Power-up to Write Operation		5	ms

3844 PGM T09

## CAPACITANCE T<sub>A</sub> = 25°C, f = 1.0MHz, V<sub>CC</sub> = 5V.

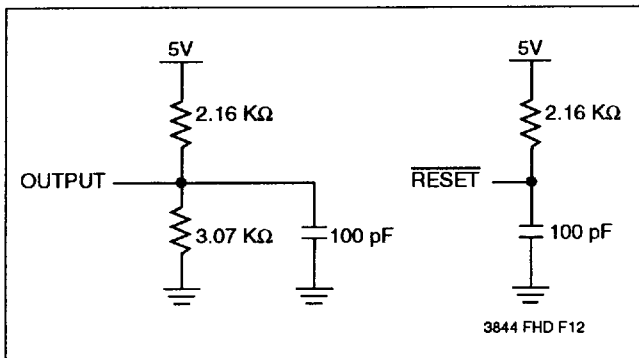
Symbol	Test	Max.	Units	Conditions
C <sub>OUT</sub> <sup>(2)</sup>	Output Capacitance (SO, RESET)	8	pF	V <sub>OUT</sub> = 0V
C <sub>IN</sub> <sup>(2)</sup>	Input Capacitance (SCK, SI, $\overline{CS}$ , WP)	6	pF	V <sub>IN</sub> = 0V

Notes: (1) V<sub>IL</sub> Min and V<sub>IH</sub> Max. are for reference only and are not tested.  
(2) This parameter is periodically sampled and not 100% tested.

3844 PGM T06

# X25043

## EQUIVALENT A.C. LOAD CIRCUIT AT 5V VCC



## A.C. TEST CONDITIONS

Input Pulse Levels	$V_{CC} \times 0.1$ to $V_{CC} \times 0.9$
Input Rise and Fall Times	10ns
Input and Output Timing Level	$V_{CC} \times 0.5$

3844 PGM T07

## A.C. CHARACTERISTICS (Over recommended operating conditions, unless otherwise specified)

### Data Input Timing

Symbol	Parameter	Min.	Max.	Units
f <sub>SCK</sub>	Clock Frequency	0	1	MHz
t <sub>CYC</sub>	Cycle Time	1000		ns
t <sub>LEAD</sub>	$\overline{CS}$ Lead Time	500		ns
t <sub>LAG</sub>	$\overline{CS}$ Lag Time	500		ns
t <sub>WH</sub>	Clock High Time	400		ns
t <sub>WL</sub>	Clock Low Time	400		ns
t <sub>SU</sub>	Data Setup Time	100		ns
t <sub>H</sub>	Data Hold Time	100		ns
t <sub>RI</sub> <sup>(3)</sup>	Data In Rise Time		2.0	μs
t <sub>FI</sub> <sup>(3)</sup>	Data In Fall Time		2.0	μs
t <sub>CS</sub>	$\overline{CS}$ Deselect Time	500		ns
t <sub>WC</sub> <sup>(4)</sup>	Write Cycle Time		10	ms

3844 PGM T08

### Data Output Timing

Symbol	Parameter	Min.	Max.	Units
f <sub>SCK</sub>	Clock Frequency	0	1	MHz
t <sub>DIS</sub>	Output Disable Time		500	ns
t <sub>V</sub>	Output Valid from clock Low		400	ns
t <sub>HO</sub>	Output Hold Time	0		ns
t <sub>RO</sub> <sup>(3)</sup>	Output Rise Time		300	ns
t <sub>FO</sub> <sup>(3)</sup>	Output Fall Time		300	ns

3844 PGM T09

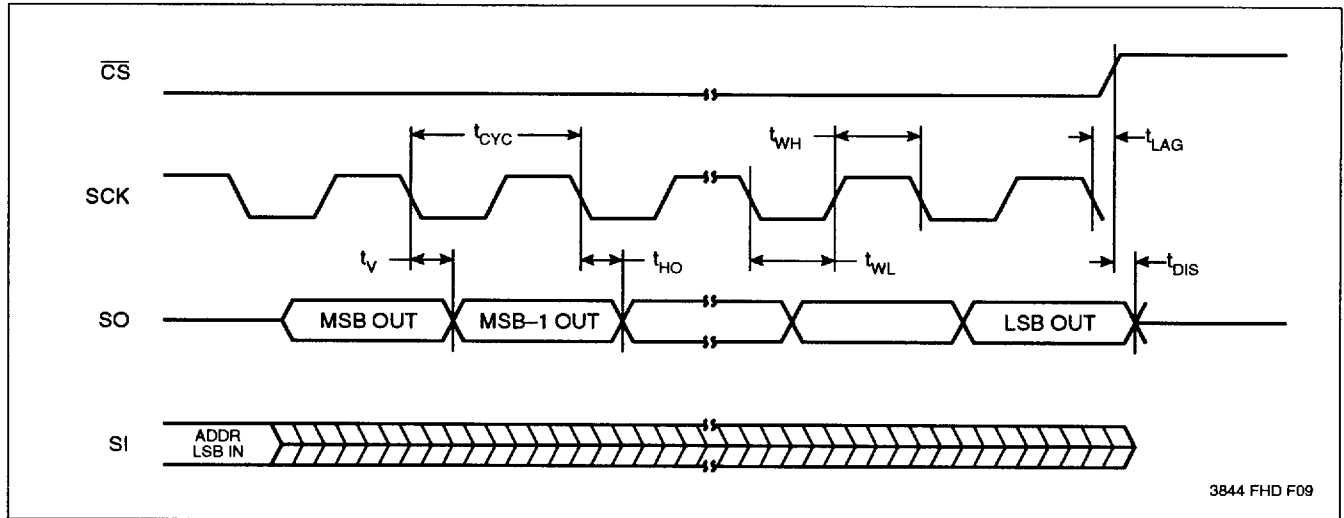
**Notes:** (3) This parameter is periodically sampled and not 100% tested.

(4) t<sub>WC</sub> is the time from the rising edge of  $\overline{CS}$  after a valid write sequence has been sent to the end of the self-timed internal nonvolatile write cycle.

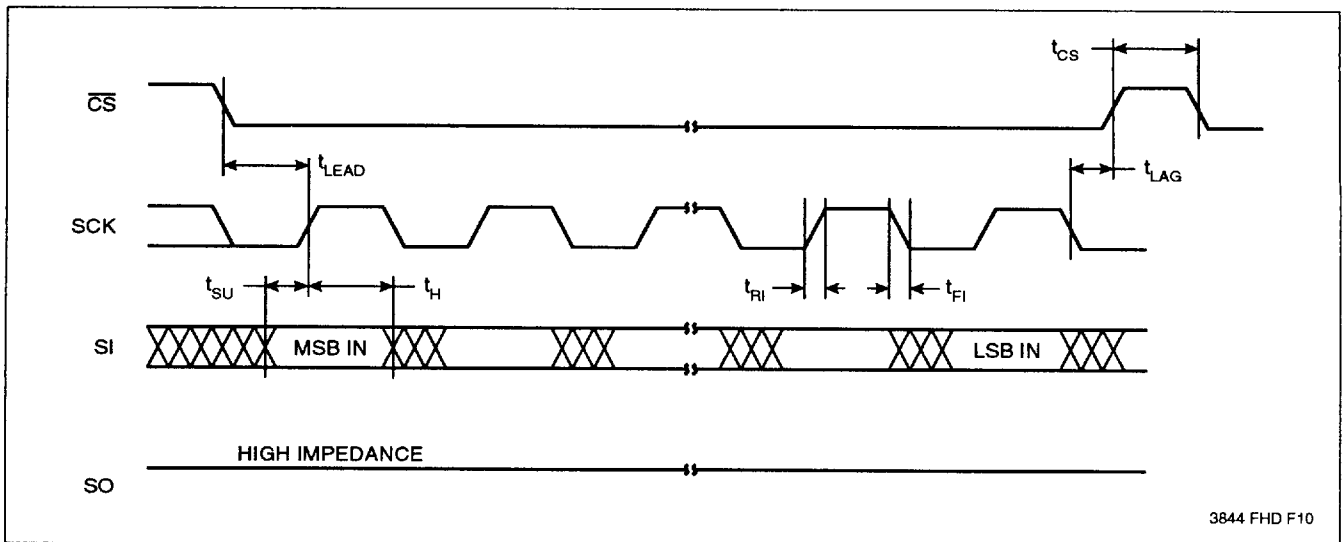


# X25043

## Serial Output Timing

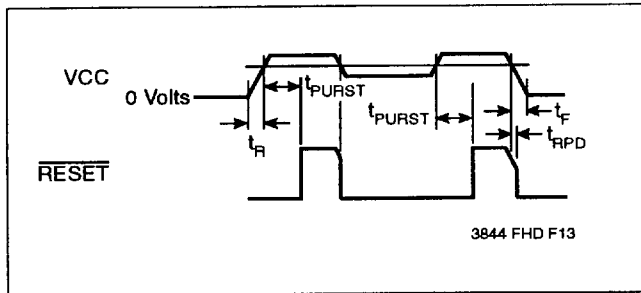


## Serial Input Timing

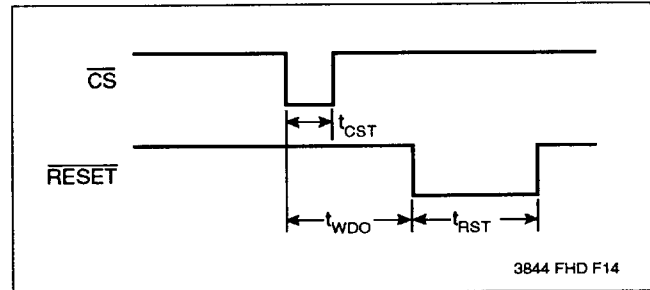


# X25043

## Power-Up and Power-Down Timing



## CS vs RESET Timing



## RESET Output Timing

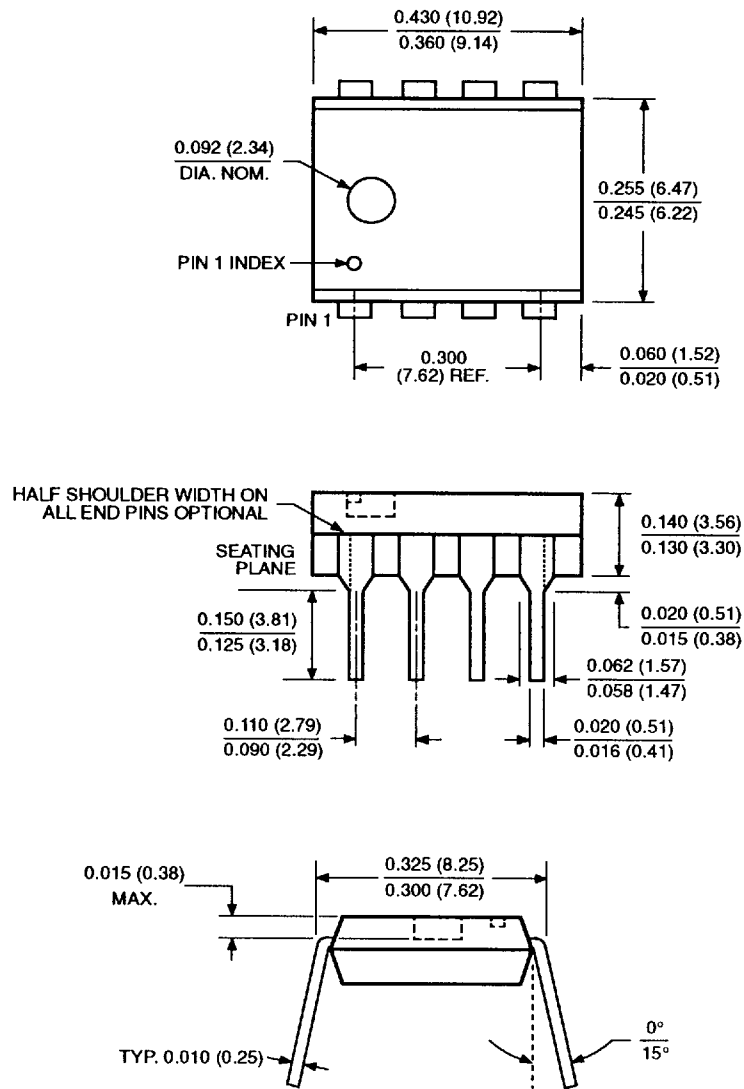
Symbol	Parameter	Min.	Typ.	Max.	Units
VTRIP	Reset Trip Point Voltage, 5V Device	4.0		4.5	V
	Reset Trip Point Voltage, 2.7V Device	2.3		2.7	V
tWDO	Watchdog Timeout Period, WD1=1, WD0=0	100	200	300	ms
	WD1=0, WD0=1	450	600	800	ms
	WD1=0, WD0=0	1.0	1.4	2.0	sec
tCST	CS Pulse Width to Reset the watchdog	400			ns
tPURST	Power-up Reset Timeout	100		400	ms
tRST	Reset Timeout	100		400	ms
tRPD(5)	VCC Detect to RESET Low			500	ns
tF(5)	VCC Fall Time	10			ns
tR(5)	VCC Rise Time	0			ns
VRVALID	Reset Valid VCC	1.0			V

3844 PGM T09

Notes: (5) This parameter is periodically sampled and not 100% tested.

PACKAGING INFORMATION

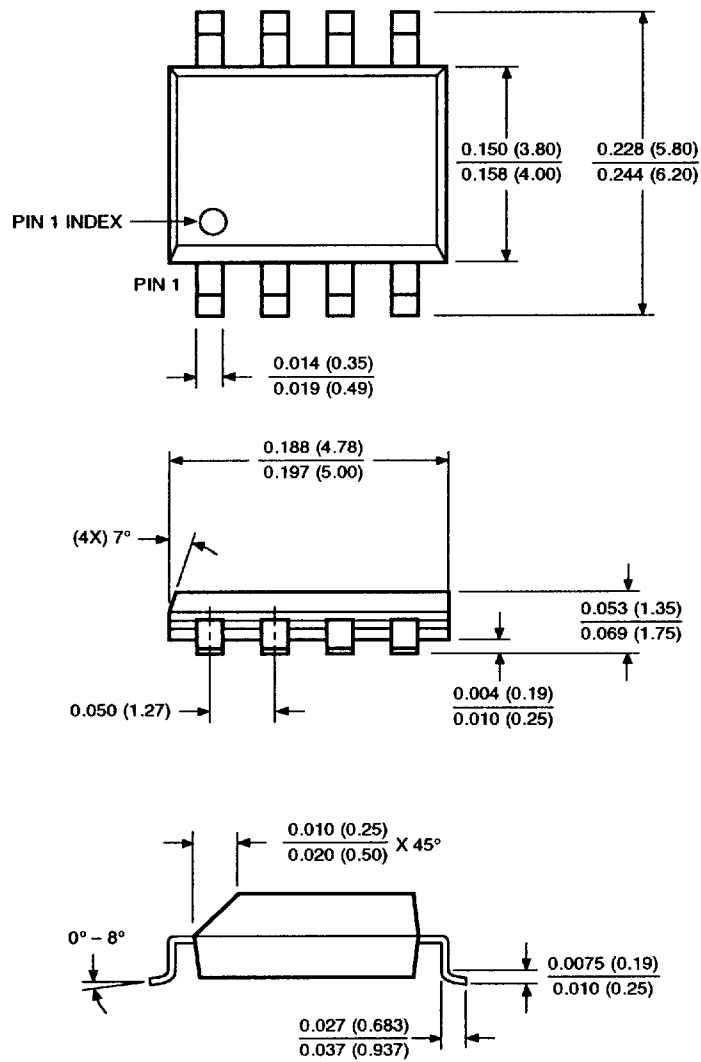
8-LEAD PLASTIC DUAL IN-LINE PACKAGE TYPE P



NOTE: ALL DIMENSIONS IN INCHES (IN PARENTHESES IN MILLIMETERS)

PACKAGING INFORMATION

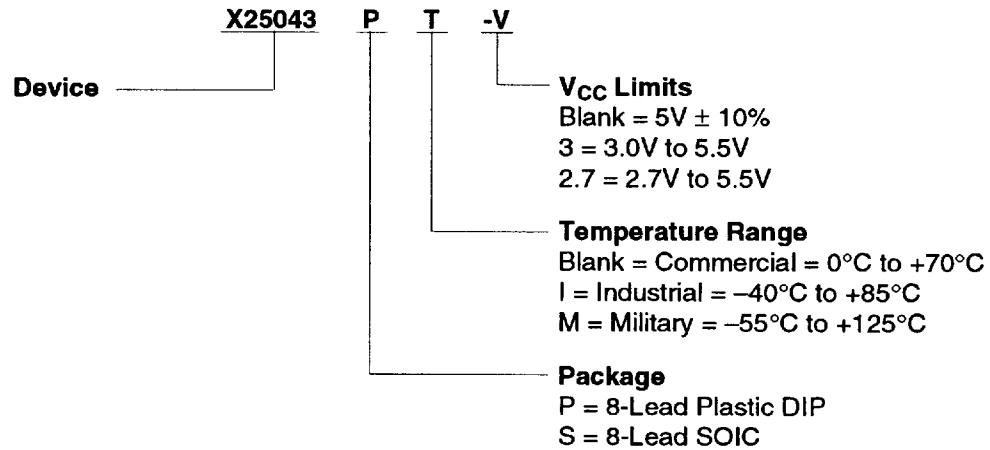
8-LEAD PLASTIC SMALL OUTLINE GULL WING PACKAGE TYPE S



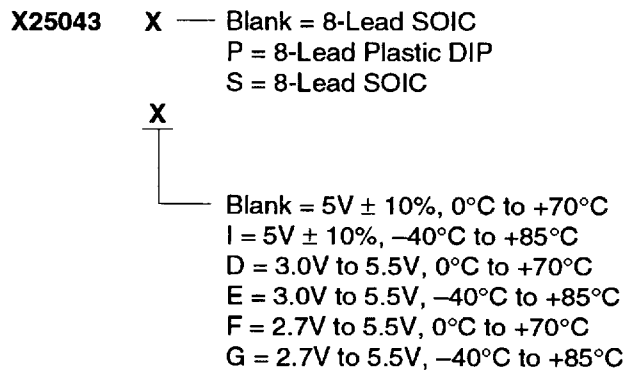
NOTE: ALL DIMENSIONS IN INCHES (IN PARENTHESIS IN MILLIMETERS)

# X25043

## ORDERING INFORMATION



## Part Mark Convention



## LIMITED WARRANTY

Devices sold by Xicor, Inc. are covered by the warranty and patent indemnification provisions appearing in its Terms of Sale only. Xicor, Inc. makes no warranty, express, statutory, implied, or by description regarding the information set forth herein or regarding the freedom of the described devices from patent infringement. Xicor, Inc. makes no warranty of merchantability or fitness for any purpose. Xicor, Inc. reserves the right to discontinue production and change specifications and prices at any time and without notice.

Xicor, Inc. assumes no responsibility for the use of any circuitry other than circuitry embodied in a Xicor, Inc. product. No other circuits, patents, licenses are implied.

## U.S. PATENTS

Xicor products are covered by one or more of the following U.S. Patents: 4,263,664; 4,274,012; 4,300,212; 4,314,265; 4,326,134; 4,393,481; 4,404,475; 4,450,402; 4,486,769; 4,488,060; 4,520,461; 4,533,846; 4,599,706; 4,617,652; 4,668,932; 4,752,912; 4,829,482; 4,874,967; 4,883,976. Foreign patents and additional patents pending.

## LIFE RELATED POLICY

In situations where semiconductor component failure may endanger life, system designers using this product should design the system with appropriate error detection and correction, redundancy and back-up features to prevent such an occurrence.

Xicor's products are not authorized for use in critical components in life support devices or systems.

1. Life support devices or systems are devices or systems which, (a) are intended for surgical implant into the body, or (b) support or sustain life, and whose failure to perform, when properly used in accordance with instructions for use provided in the labeling, can be reasonably expected to result in a significant injury to the user.
2. A critical component is any component of a life support device or system whose failure to perform can be reasonably expected to cause the failure of the life support device or system, or to affect its safety or effectiveness.