

Structure Silicon monolithic integrated circuit
 Product NTSC/PAL Digital Video Encoder

Type **BU9972GU**

Features

Video Format: NTSC-M, PAL-B/D/G/H/I standard compliant
 Input Image Data Format: YCbCr 4:2:2 8 bits/16 bits, RGB 16 bits (R: 5 bits/G: 6 bits/B: 5 bits)
 BUS I/F: Master / Slave mode Support
 10-bit Video-DAC Built-in, PLL Built-in
 Image Expansion Function, Image Display Position Adjustment Function

○ Absolute Maximum Ratings (Ta = 25°C)

Parameter	Symbol	Ratings	Unit
Digital supply voltage	DVDD	-0.2 ~ 2.5	V
PLL supply voltage	PVDD	-0.2 ~ 2.5	V
DAC supply voltage	AVDD	-0.2 ~ 4.5	V
I/O supply voltage	IOVDD	-0.2 ~ 4.5	V
Power dissipation (*1)	Pd	570	mW
Storage temperature range	Tstg	-25 ~ +125	°C

(*1) A measured value at mounting on a board (Size: 114.3mm x 76.2mm x 1.6mm, 4-layer) implemented in relation to SEMI.

In the case of exceeding Ta=25°C, 5.7mW should be reduced per 1°C.

- * The radiation-resistance design is not carried out.
- * Operation is not guaranteed.

○ Operating Conditions (Ta= -20~+70°C)

Parameter	Symbol	Min.	Typ.	Max.	Unit
Digital supply voltage	DVDD	1.7	1.8	1.9	V
PLL supply voltage	PVDD	1.7	1.8	1.9	V
DAC supply voltage	AVDD	2.7	2.85	3.0	V
I/O supply voltage (*1)	IOVDD	1.7	1.8	1.9	V
		2.7	2.85	3.0	V

(*1) Usage limitation: IOVDD = 1.8V±0.1V or 2.85V±0.15V

Application example

- ROHM cannot provide adequate confirmation of patents.
- The product described in this document is designed to be used with ordinary electronic equipment or devices (such as audio-visual equipment, office-automation equipment, communications devices, electrical appliances, and electronic toys). Should you intend to use this product with equipment or devices which require an extremely high level of reliability and the malfunction of which would directly endanger human life (such as medical instruments, transportation equipment, aerospace machinery, nuclear-reactor controllers, fuel controllers and other safety devices), please be sure to consult with our sales representative in advance.
- ROHM assumes no responsibility for use of any circuits described herein, conveys no license under any patent or other right, and makes no representations that the circuits are free from patent infringement.

○ Electrical characteristics

(Unless otherwise noted, Ta=25°C, DVDD=PVDD=1.8V, IOVDD=2.85V, AVDD=2.85V, DVSS=PVSS=IOVSS=AVSS=GND=0V)

Parameter	Symbol	Mi.	Typ.	Max.	Unit	Conditions
Digital Operating Current	IDDCO	-	40	60	mA	Ta=25°C (*1)
I/O Operating Current	IDDIO	-	5	10	mA	Ta=25°C (*1)
Digital Static Current	ISTDCO	-	10	25	μA	RESETB=GND, Ta=25°C
I/O Static Current	ISTDIO	-	5	15	μA	RESETB=GND, Ta=25°C Fix input terminals to GND.
H Input Voltage	VIH	IOVDD *0.8	-	IOVDD +0.2	V	
L Input Voltage	VIL	-0.2	-	IOVDD *0.2	V	
H/L Input Leak Current	IIL	-3	-	3	μA	VIN=IOVDD/GND
H Input Current	IIHT	10	-	200	μA	VIN=IOVDD
H Output Voltage	VOH	IOVDD -0.4	-	IOVDD	V	IOH=2mA
L Output Voltage	VOL	IOVSS	-	0.4	V	IOL=2mA
Video DAC Resolution	RES	-	-	10	Bits	
Video DAC Operating Current	IDDV	-	38	45	mA	RL=37.5Ω, RIREF=1.2kΩ
Video DAC Static Current	ISTV	-	1	5	μA	RESETB=GND, Ta=25°C
PLL Operating Current	IDDP	-	0.5	1.5	mA	
PLL Static Current	ISTP	-	1	5	μA	RESETB=GND, Ta=25°C

(*1) A measured value at QVGA color-bar image output in expand mode.

○ Block diagram

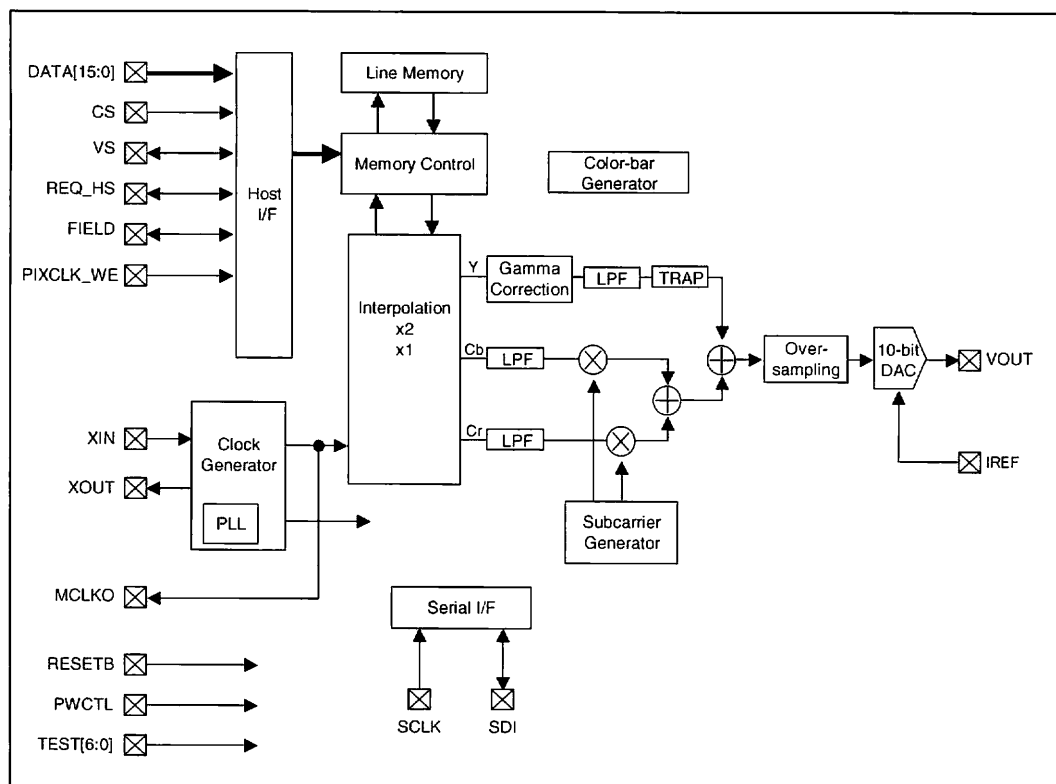

○ Terminal functions

Terminal No.	Terminal name	Description of terminals	Terminal No.	Terminal name	Description of terminals	Terminal No.	Terminal name	Description of terminals
1	TEST0	Test pin.	23	DATA14	Pixel data input.	45	GND	Connect to ground.
2	N.C.	No Connection.	24	DATA13	Pixel data input.	46	REQ_HS	Data request / Horizontal synchronizing signal.
3	TEST1	Test pin.	25	DATA12	Pixel data input.	47	GND	Connect to ground.
4	TEST2	Test pin.	26	DATA11	Pixel data input.	48	VS	Vertical synchronizing signal.
5	GND	Connect to ground.	27	GND	Connect to ground.	49	DVDD	Digital power supply.
6	SCLK	Serial clock.	28	DATA10	Pixel data input.	50	GND	Connect to ground.
7	SDI	Serial data.	29	DATA9	Pixel data input.	51	DVSS	Connect to ground.
8	TEST3	Test pin.	30	DATA8	Pixel data input.	52	GND	Connect to ground.
9	GND	Connect to ground.	31	GND	Connect to ground.	53	CS	Identify whether input pixel data is valid or not.
10	PVSS	PLL ground.	32	DATA7	Pixel data input.	54	FIELD	Field identification signal.
11	GND	Connect to ground.	33	DVSS	Connect to ground.	55	PWCTL	Power down control input.
12	DVDD	Digital power supply.	34	GND	Connect to ground.	56	TEST4	Test pin.
13	PVDD	PLL power supply.	35	DVDD	Digital power supply.	57	TEST5	Test pin.
14	MCLKO	System clock signal output.	36	DATA6	Pixel data input.	58	TEST6	Test pin.
15	XIN	PLL reference clock output / connect to oscillator.	37	DATA5	Pixel data input.	59	AVSS	DAC ground.
16	XOUT	Oscillator output.	38	DATA4	Pixel data input.	60	IREF	Reference voltage output for DAC.
17	IOVDD	I/O power supply.	39	DATA3	Pixel data input.	61	AVDD	DAC power supply.
18	GND	Connect to ground.	40	DATA2	Pixel data input.	62	GND	Connect to ground.
19	IOVSS	Connect to ground.	41	GND	Connect to ground.	63	VOUT	Analog composite video signal output.
20	GND	Connect to ground.	42	DATA1	Pixel data input.	64	GND	Connect to ground.
21	RESETB	System reset input.	43	DATA0	Pixel data input.			
22	DATA15	Pixel data input.	44	PIXCLK_WE	Pixel clock input.			

○ Package outline

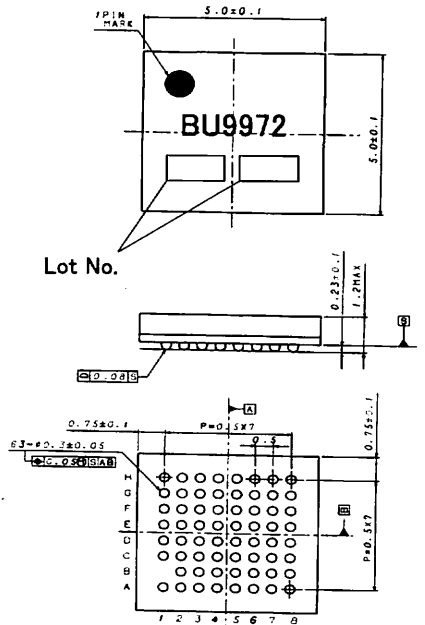

VBGA063T050 (Unit: mm)

○ Ball assignment (Bottom View)

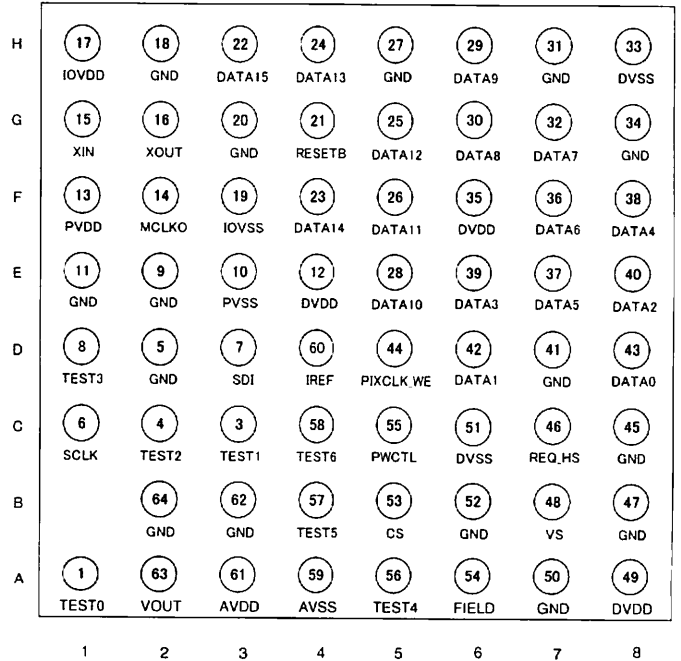

○ Cautions on use

(1) Absolute Maximum Ratings

An excess in the absolute maximum ratings, such as supply voltage, temperature range of operating conditions, etc., can break down devices, thus making impossible to identify breaking mode such as a short circuit or an open circuit. If any special mode exceeding the absolute maximum ratings is assumed, consideration should be given to take physical safety measures including the use of fuses, etc.

(2) Operating conditions

These conditions represent a range within which characteristics can be provided approximately as expected. The electrical characteristics are guaranteed under the conditions of each parameter.

(3) Reverse connection of power supply connector

The reverse connection of power supply connector can break down ICs. Take protective measures against the breakdown due to the reverse connection, such as mounting an external diode between the power supply and the IC's power supply terminal.

(4) Power supply line

Design PCB pattern to provide low impedance for the wiring between the power supply and the GND lines. In this regard, for the digital block power supply and the analog block power supply, even though these power supplies has the same level of potential, separate the power supply pattern for the digital block from that for the analog block, thus suppressing the diffraction of digital noises to the analog block power supply resulting from impedance common to the wiring patterns. For the GND line, give consideration to design the patterns in a similar manner.

Furthermore, for all power supply terminals to ICs, mount a capacitor between the power supply and the GND terminal. At the same time, in order to use an electrolytic capacitor, thoroughly check to be sure the characteristics of the capacitor to be used present no problem including the occurrence of capacity dropout at a low temperature, thus determining the constant.

(5) GND voltage

Make setting of the potential of the GND terminal so that it will be maintained at the minimum in any operating state. Furthermore, check to be sure no terminals are at a potential lower than the GND voltage including an actual electric transient.

(6) Short circuit between terminals and erroneous mounting

In order to mount ICs on a set PCB, pay thorough attention to the direction and offset of the ICs. Erroneous mounting can break down the ICs. Furthermore, if a short circuit occurs due to foreign matters entering between terminals or between the terminal and the power supply or the GND terminal, the ICs can break down.

(7) Operation in strong electromagnetic field

Be noted that using ICs in the strong electromagnetic field can malfunction them.

(8) Inspection with set PCB

On the inspection with the set PCB, if a capacitor is connected to a low-impedance IC terminal, the IC can suffer stress. Therefore, be sure to discharge from the set PCB by each process. Furthermore, in order to mount or dismount the set PCB to/from the jig for the inspection process, be sure to turn OFF the power supply and then mount the set PCB to the jig. After the completion of the inspection, be sure to turn OFF the power supply and then dismount it from the jig. In addition, for protection against static electricity, establish a ground for the assembly process and pay thorough attention to the transportation and the storage of the set PCB.

(9) Input terminals

In terms of the construction of IC, parasitic elements are inevitably formed in relation to potential. The operation of the parasitic element can cause interference with circuit operation, thus resulting in a malfunction and then breakdown of the input terminal. Therefore, pay thorough attention not to handle the input terminals, such as to apply to the input terminals a voltage lower than the GND respectively, so that any parasitic element will operate. Furthermore, do not apply a voltage to the input terminals when no power supply voltage is applied to the IC. In addition, even if the power supply voltage is applied, apply to the input terminals a voltage lower than the power supply voltage or within the guaranteed value of electrical characteristics.

(10) Ground wiring pattern

If small-signal GND and large-current GND are provided, It will be recommended to separate the large-current GND pattern from the small-signal GND pattern and establish a single ground at the reference point of the set PCB so that resistance to the wiring pattern and voltage fluctuations due to a large current will cause no fluctuations in voltages of the small-signal GND. Pay attention not to cause fluctuations in the GND wiring pattern of external parts as well.

(11) External capacitor

In order to use a ceramic capacitor as the external capacitor, determine the constant with consideration given to a degradation in the nominal capacitance due to DC bias and changes in the capacitance due to temperature, etc.

Notes

- No technical content pages of this document may be reproduced in any form or transmitted by any means without prior permission of ROHM CO.,LTD.
- The contents described herein are subject to change without notice. The specifications for the product described in this document are for reference only. Upon actual use, therefore, please request that specifications to be separately delivered.
- Application circuit diagrams and circuit constants contained herein are shown as examples of standard use and operation. Please pay careful attention to the peripheral conditions when designing circuits and deciding upon circuit constants in the set.
- Any data, including, but not limited to application circuit diagrams information, described herein are intended only as illustrations of such devices and not as the specifications for such devices. ROHM CO.,LTD. disclaims any warranty that any use of such devices shall be free from infringement of any third party's intellectual property rights or other proprietary rights, and further, assumes no liability of whatsoever nature in the event of any such infringement, or arising from or connected with or related to the use of such devices.
- Upon the sale of any such devices, other than for buyer's right to use such devices itself, resell or otherwise dispose of the same, no express or implied right or license to practice or commercially exploit any intellectual property rights or other proprietary rights owned or controlled by
- ROHM CO., LTD. is granted to any such buyer.
- Products listed in this document are no antiradiation design.

The products listed in this document are designed to be used with ordinary electronic equipment or devices (such as audio visual equipment, office-automation equipment, communications devices, electrical appliances and electronic toys).

Should you intend to use these products with equipment or devices which require an extremely high level of reliability and the malfunction of which would directly endanger human life (such as medical instruments, transportation equipment, aerospace machinery, nuclear-reactor controllers, fuel controllers and other safety devices), please be sure to consult with our sales representative in advance.

About Export Control Order in Japan

Products described herein are the objects of controlled goods in Annex 1 (Item 16) of Export Trade Control Order in Japan.

In case of export from Japan, please confirm if it applies to "objective" criteria or an "informed" (by MITI clause) on the basis of "catch all controls for Non-Proliferation of Weapons of Mass Destruction.

Thank you for your accessing to ROHM product informations.
More detail product informations and catalogs are available,
please contact your nearest sales office.

Please contact our sales offices for details ;

U.S.A / San Diego	TEL : +1(858)625-3630	FAX : +1(858)625-3670
Atlanta	TEL : +1(770)754-5972	FAX : +1(770)754-0691
Dallas	TEL : +1(972)312-8818	FAX : +1(972)312-0330
Germany / Dusseldorf	TEL : +49(2154)9210	FAX : +49(2154)921400
United Kingdom / London	TEL : +44(1)908-282-666	FAX : +44(1)908-282-528
France / Paris	TEL : +33(0)1 56 97 30 60	FAX : +33(0) 1 56 97 30 80
China / Hong Kong	TEL : +852(2)740-6262	FAX : +852(2)375-8971
Shanghai	TEL : +86(21)6279-2727	FAX : +86(21)6247-2066
Dilian	TEL : +86(411)8230-8549	FAX : +86(411)8230-8537
Beijing	TEL : +86(10)8525-2483	FAX : +86(10)8525-2489
Taiwan / Taipei	TEL : +866(2)2500-6956	FAX : +866(2)2503-2869
Korea / Seoul	TEL : +82(2)8182-700	FAX : +82(2)8182-715
Singapore	TEL : +65-6332-2322	FAX : +65-6332-5662
Malaysia / Kuala Lumpur	TEL : +60(3)7958-8355	FAX : +60(3)7958-8377
Philippines / Manila	TEL : +63(2)807-6872	FAX : +63(2)809-1422
Thailand / Bangkok	TEL : +66(2)254-4890	FAX : +66(2)256-6334

Japan /
(Internal Sales)

Tokyo	2-1-1, Yaesu, Chuo-ku, Tokyo 104-0082	TEL : +81(3)5203-0321	FAX : +81(3)5203-0300
Yokohama	2-4-8, Shin Yokohama, Kohoku-ku, Yokohama, Kanagawa 222-8575	TEL : +81(45)476-2131	FAX : +81(45)476-2128
Nagoya	Dainagayo Building 9F 3-28-12, Meieki, Nakamura-ku, Nagoya, Aichi 450-0002	TEL : +81(52)581-8521	FAX : +81(52)561-2173
Kyoto	579-32 Higashi Shiokouji-cho, Karasuma Nishi-iru, Shiokoujidori, Shimogyo-ku, Kyoto 600-8216	TEL : +81(75)311-2121	FAX : +81(75)314-6559

(Contact address for overseas customers in Japan)

Yokohama	TEL : +81(45)476-9270	FAX : +81(045)476-9271
----------	-----------------------	------------------------