

HIGH FREQUENCY NPN TRANSISTOR ARRAY

FEATURES

- 9 GHz CONFIGURABLE TRANSISTOR BASED OR/NOR CIRCUITRY
- OUTSTANDING h_{FE} LINEARITY
- TWO PACKAGE OPTIONS:
 - μ PA104B: Studied ceramic package provides superior thermal dissipation
 - μ PA104G: Reduced circuit size due to 14-pin plastic SOP package for surface mounting
- EXCELLENT FOR ANALOG ADDITIONS & FORMATION OF 2-INPUT OR/NOR GATES

DESCRIPTION AND APPLICATIONS

The μ PA104 is a user-configurable, Si bipolar transistor array for formation of high speed OR/NOR gates. Its internal transistor configuration and external connection options allow the user considerable flexibility in its application. Its high gain bandwidth product ($f_T = 9$ GHz) make it applicable for electro-optical, signal processing, cellular telephone systems, instrumentation, and high speed gigabit logic circuits.

ORDERING INFORMATION

PART NUMBER	PACKAGE
μ PA104B-E1	14-pin ceramic package
μ PA104G-E1	14-pin plastic SOP (225 mil)

ABSOLUTE MAXIMUM RATINGS ($T_A = +25$ °C)

SYMBOLS	PARAMETERS	UNITS	RATINGS
V_{CBO}^*	Collector to Base Voltage	V	15
V_{CEO}^*	Collector to Emitter Voltage	V	6
V_{EBO}^*	Emitter to Base Voltage	V	2.5
I_C^*	Collector Current	mA	40
P_T	Power Dissipation		
	μ PA104B	mW	650
	μ PA104G	mW	350
T_J	Junction Temperature		
	μ PA104B	°C	200
	μ PA104G	°C	125
T_{STG}	Storage Temperature		
	μ PA104B	°C	-55 to +200
	μ PA104G	°C	-55 to +125

* Absolute maximum ratings for each transistor.

Caution electro-static sensitive devices

The information in this document is subject to change without notice. Before using this document, please confirm that this is the latest version.
Not all devices/types available in every country. Please check with local NEC representative for availability and additional information.

PACKAGE DIMENSIONS (UNIT: mm)

μPA104B

14 PIN CERAMIC PACKAGE

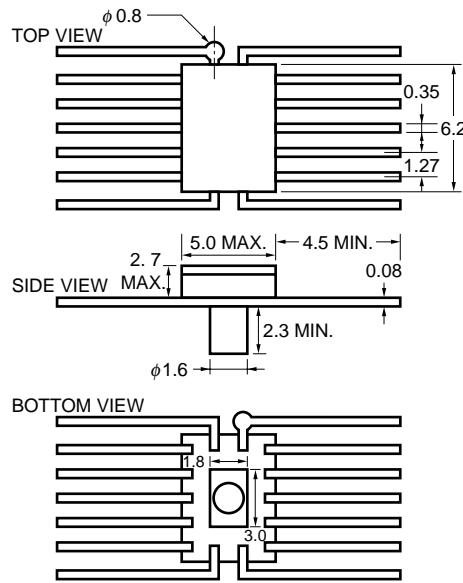

μPA104G

★ 14 PIN PLASTIC SOP (225 mil)

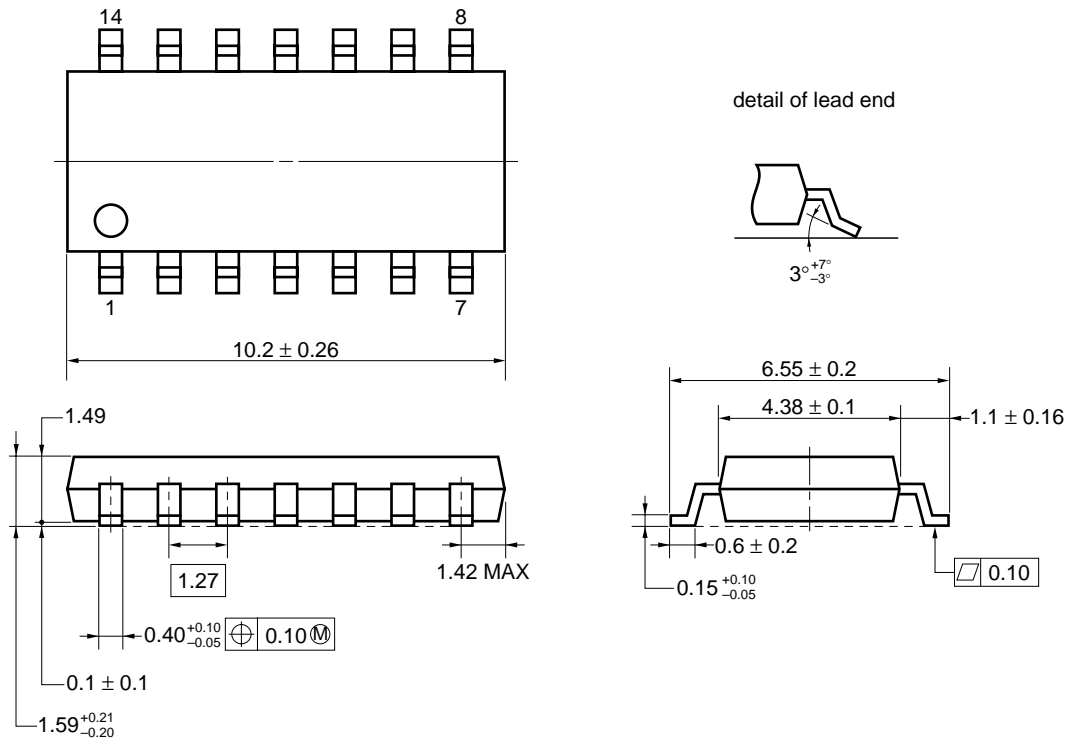

NOTE Each lead centerline is located within 0.10 mm of its true position (T.P.) at maximum material condition.

See connection diagram for description of leads.

ELECTRICAL CHARACTERISTICS (Unless otherwise specified $T_A = +25\text{ }^\circ\text{C}$ μPA104B, μPA104G common)

SYMBOLS	PARAMETERS AND CONDITIONS	UNITS	MIN.	TYP.	MAX.
I_{CBO}	Collector Cutoff Current at $V_{CB} = 5\text{ V}$, $I_E = 0$ (Q1 thru Q6)	μA			1.0
I_{EBO}	Emitter Cutoff Current at $V_{EB} = 1\text{ V}$, $I_C = 0$ (Q4 thru Q6)	μA			1.0
h_{FE}	Direct Current Amplification at $V_{CE} = 3\text{ V}$, $I_C = 5\text{ mA}$ (Q4 and Q6)		40	100	250
C_{CB}	Collector to Base Capacitance at $V_{CB} = 3\text{ V}$, $f = 1\text{ MHz}$ (Q3, Q5, Q6)	pF		0.9	1.8
C_{EB}	Emitter to Base Capacitance at $V_{EB} = 0$, $f = 1\text{ MHz}$ (Q4 thru Q6)	pF		1.4	2.8
C_{CS}	Collector/Substrate Capacitance, $V_{CS} = 3\text{ V}$, $f = 1\text{ MHz}$ (Q3, Q5, Q6)	pF		1.4	2.8
f_T	Gain Bandwidth Product* at $V_{CE} = 3\text{ V}$, $I_C = 10\text{ mA}$	GHZ		9.0	

* Measured by installing a single transistor in a Micro-X package: the value shown is a reference value.

CONNECTION DIAGRAM (Top View)

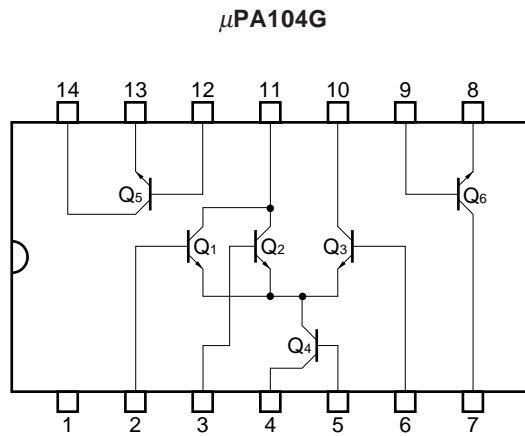
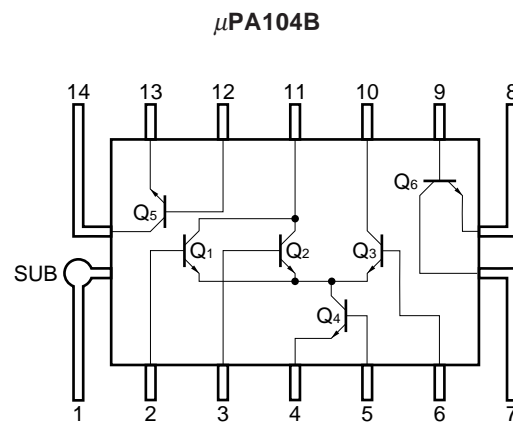

Note: Substrate should be connected to the lowest voltage point in order to prevent latch-up.

TYPICAL PERFORMANCE CHARACTERISTICS ($T_A = +25\text{ }^\circ\text{C}$)

COLLECTOR CURRENT vs. COLLECTOR TO EMITTER VOLTAGE

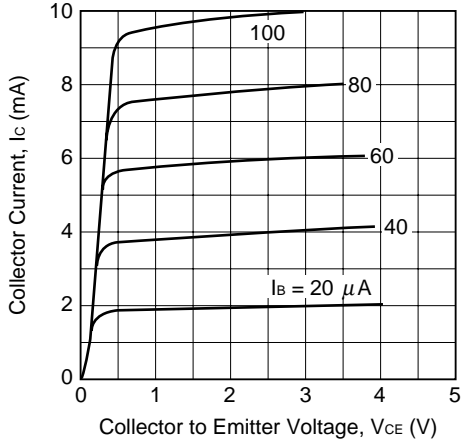

COLLECTOR CURRENT vs. BASE TO EMITTER VOLTAGE

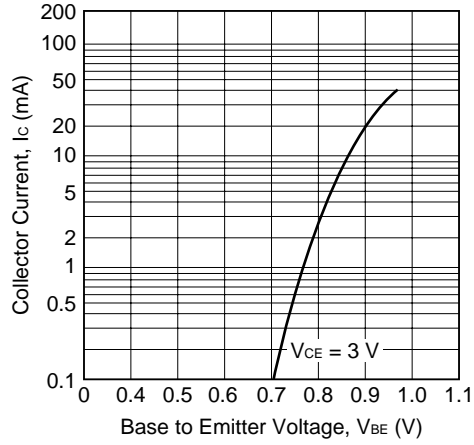

DC CURRENT GAIN vs. COLLECTOR CURRENT

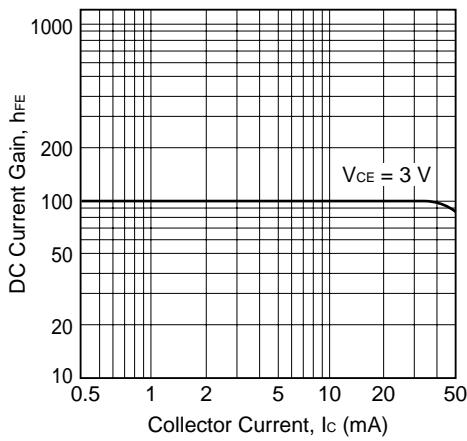

GAIN BANDWIDTH PRODUCT vs. COLLECTOR CURRENT

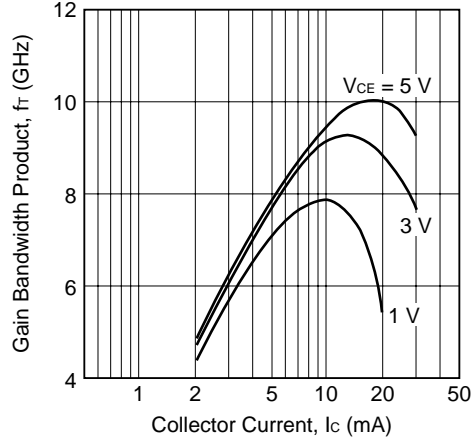

GAIN AND NOISE FIGURE OF INDIVIDUAL TRANSISTOR

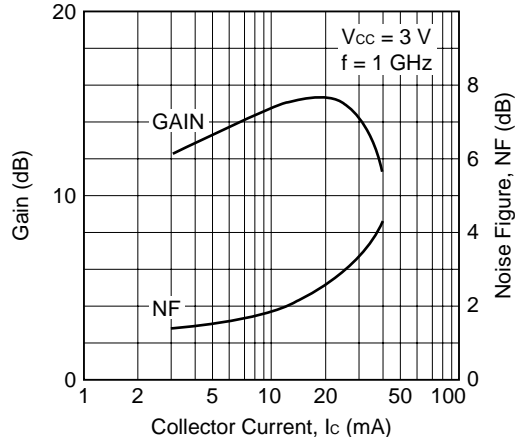

TYPICAL APPLICATION

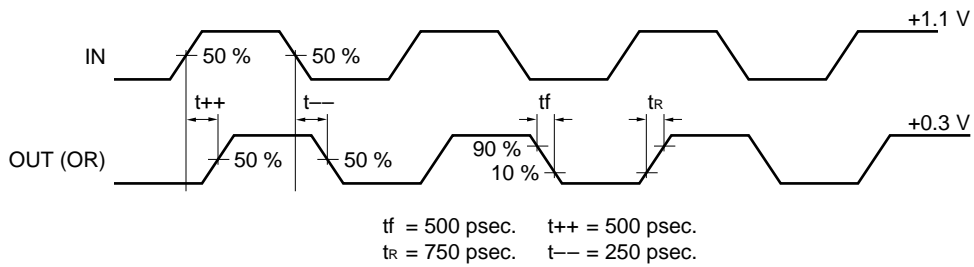
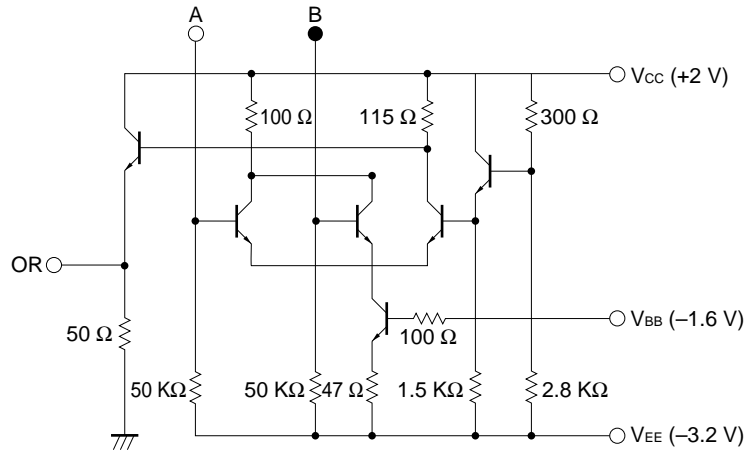
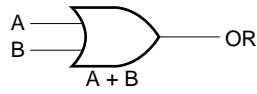

The application circuits and their parameters are for references only and are not intended for use in actual design-in's.

NOTES ON CORRECT USE

- (1) Observe precautions for handling because of electro-static sensitive devices.
- (2) Form a ground pattern as wide as possible to maintain the minimum ground impedance (to prevent undesired oscillation).
- (3) Design circuits connected Sub pin to the lowest voltage to prevent latch-up.
- (4) Design circuits as each pin voltage difference within 15 V maximum.

RECOMMENDED SOLDERING CONDITIONS

This product should be soldered in the following recommended conditions. Other soldering methods and conditions than the recommended conditions are to be consulted with our sales representatives.

μPA104G

Soldering process	Soldering conditions	Recommended condition symbol
Infrared ray reflow	Package peak temperature: 235 °C, Hour: within 30 s. (more than 210 °C), Time: 2 times, Limited days: no. ^{Note}	IR35-00-2
VPS	Package peak temperature: 215 °C, Hour: within 40 s. (more than 200 °C), Time: 2 times, Limited days: no. ^{Note}	VP15-00-2
Wave soldering	Soldering tub temperature: less than 260 °C, Hour: within 10 s. Time: 1 time, Limited days: no. ^{Note}	WS60-00-1
Pin part heating	Pin area temperature: less than 300 °C, Hour: within 3 s./pin Limited days: no. ^{Note}	

μPA104B

Soldering process	Soldering conditions	Symbol
Infrared ray reflow	Peak package's surface temperature: 230 °C or below, Reflow time: 10 seconds or below (210 °C or higher), Number of reflow process: 1, Exposure limit*: None	
Partial heating method	Terminal temperature: 260 °C or below, Flow time: 10 seconds or below, Exposure limit*: None	

Note It is the storage days after opening a dry pack, the storage conditions are 25 °C, less than 65 % RH.

Caution The combined use of soldering method is to be avoided (However, except the pin area heating method).

For details of recommended soldering conditions for surface mounting, refer to information document SEMICONDUCTOR DEVICE MOUNTING TECHNOLOGY MANUAL (C10535E).

[MEMO]

NESAT (NEC Silicon Advanced Technology) is a trademark of NEC Corporation.

- **The information in this document is subject to change without notice. Before using this document, please confirm that this is the latest version.**
 - No part of this document may be copied or reproduced in any form or by any means without the prior written consent of NEC Corporation. NEC Corporation assumes no responsibility for any errors which may appear in this document.
 - NEC Corporation does not assume any liability for infringement of patents, copyrights or other intellectual property rights of third parties by or arising from use of a device described herein or any other liability arising from use of such device. No license, either express, implied or otherwise, is granted under any patents, copyrights or other intellectual property rights of NEC Corporation or others.
 - Descriptions of circuits, software, and other related information in this document are provided for illustrative purposes in semiconductor product operation and application examples. The incorporation of these circuits, software, and information in the design of the customer's equipment shall be done under the full responsibility of the customer. NEC Corporation assumes no responsibility for any losses incurred by the customer or third parties arising from the use of these circuits, software, and information.
 - While NEC Corporation has been making continuous effort to enhance the reliability of its semiconductor devices, the possibility of defects cannot be eliminated entirely. To minimize risks of damage or injury to persons or property arising from a defect in an NEC semiconductor device, customers must incorporate sufficient safety measures in its design, such as redundancy, fire-containment, and anti-failure features.
 - NEC devices are classified into the following three quality grades:
"Standard", "Special", and "Specific". The Specific quality grade applies only to devices developed based on a customer designated "quality assurance program" for a specific application. The recommended applications of a device depend on its quality grade, as indicated below. Customers must check the quality grade of each device before using it in a particular application.
 - Standard: Computers, office equipment, communications equipment, test and measurement equipment, audio and visual equipment, home electronic appliances, machine tools, personal electronic equipment and industrial robots
 - Special: Transportation equipment (automobiles, trains, ships, etc.), traffic control systems, anti-disaster systems, anti-crime systems, safety equipment and medical equipment (not specifically designed for life support)
 - Specific: Aircraft, aerospace equipment, submersible repeaters, nuclear reactor control systems, life support systems or medical equipment for life support, etc.
- The quality grade of NEC devices is "Standard" unless otherwise specified in NEC's Data Sheets or Data Books. If customers intend to use NEC devices for applications other than those specified for Standard quality grade, they should contact an NEC sales representative in advance.