

MAXIM

MAX4141 Evaluation Kit

Evaluates: MAX4141

General Description

The MAX4141 evaluation kit (EV kit) simplifies the evaluation of the MAX4141 wideband 330MHz, 4x1 multiplexer. Access to all inputs is through RF style connectors (SMA). A special scope-probe jack is provided for easy output monitoring on an oscilloscope. A three-position dip switch allows simple control of the enable and address functions.

Component List

DESIGNATION	QTY	DESCRIPTION
U1	1	MAX4141CSD
C1, C4	2	10 μ F, 10V tantalum capacitors Sprague 293D106X0010B2 AVX TAJB106M010
C3, C5	2	1000pF ceramic capacitors Vishay/Vitramon VJ1206Y102KXX Murata-Erie GRM42-6X7R102K025
C2, C6	2	0.1 μ F ceramic capacitors Vishay/Vitramon VJ1206Y104KXX Murata-Erie GRM42-6X7R104K025
R1-R4	4	51 Ω , 5% resistors
R5, R6, R7	3	10k Ω , 5% resistors
SW1	1	3-position dip switch
IN0-IN3	4	SMA jacks
OUT	1	Scope-probe jack Specialty Connectors 33JR135-1
None	1	MAX4141 PC board
None	1	MAX4141 data sheet

Component Suppliers

SUPPLIER	PHONE	FAX
AVX	(207) 282-5111	(207) 283-1941
Murata-Erie	(814) 237-1431	(814) 238-0490
Specialty Connectors	(317) 738-2800	(317) 738-2858
Sprague	(603) 224-1961	(603) 224-1430
Vishay/Vitramon	(203) 268-6261	(203) 452-5670

Features

- ◆ 330MHz -3dB Bandwidth
- ◆ \pm 5V Supply Operation
- ◆ Logic Disable Mode:
 - High-Z Outputs
 - Reduced Power Consumption
- ◆ Fully Assembled and Tested

Ordering Information

PART	TEMP. RANGE	BOARD TYPE
MAX4141EVKIT-SO	+25°C	Surface Mount

Quick Start

The MAX4141 EV kit is fully assembled and tested. Follow these steps to verify board operation. **Do not turn on the power supply until all connections are completed.**

- 1) The circuit requires \pm 5V supply voltages. Connect the +5V supply to the VCC pad, and the -5V supply to the VEE pad. Connect power-supply ground to the pad marked GND.
- 2) On dip switch SW1, set A0 and A1 to logic 0, and set ENABLE to logic 1.
- 3) Apply a signal of \pm 2.5V maximum to the SMA jack input marked IN0.
- 4) Insert an oscilloscope probe into the scope-probe connector labeled OUT. Be sure the scope ground makes contact with the outside of the connector.
- 5) Turn on the power supply and verify the output signal on the oscilloscope. The board should not draw more than 10mA from each supply.
- 6) Accurate gain-flatness measurement:
 - a) Apply a signal to an input.
 - b) Take the measurement with high-frequency FET probes at the pins of the IC, not at the connectors.

MAX4141 Evaluation Kit

Detailed Description

Address and Enable Control

Dip switch SW1 allows simple control of the address lines A0 and A1 as well as the enable function. Refer to Table 1 for switch settings. User pads marked A0, A1, and ENABLE are provided for using an external controller. Note that there are 10kΩ pull-up resistors to VCC on the A0, A1, and ENABLE lines.

Layout Considerations

The MAX4141 evaluation board layout is optimized for high-speed signals. Input traces are 50Ω transmission lines created with microstrip techniques. Ceramic bypass capacitors are located as close to the MAX4141 supply pins as possible to minimize parasitic inductances. Further layout recommendations can be found in the *Grounding, Bypassing, and PC Board Layout* section of the MAX4141 data sheet.

Table 1. Truth Table

A1	A0	ENABLE	OUT
X	X	0	High-Z
0	0	1	IN0
0	1	1	IN1
1	0	1	IN2
1	1	1	IN3

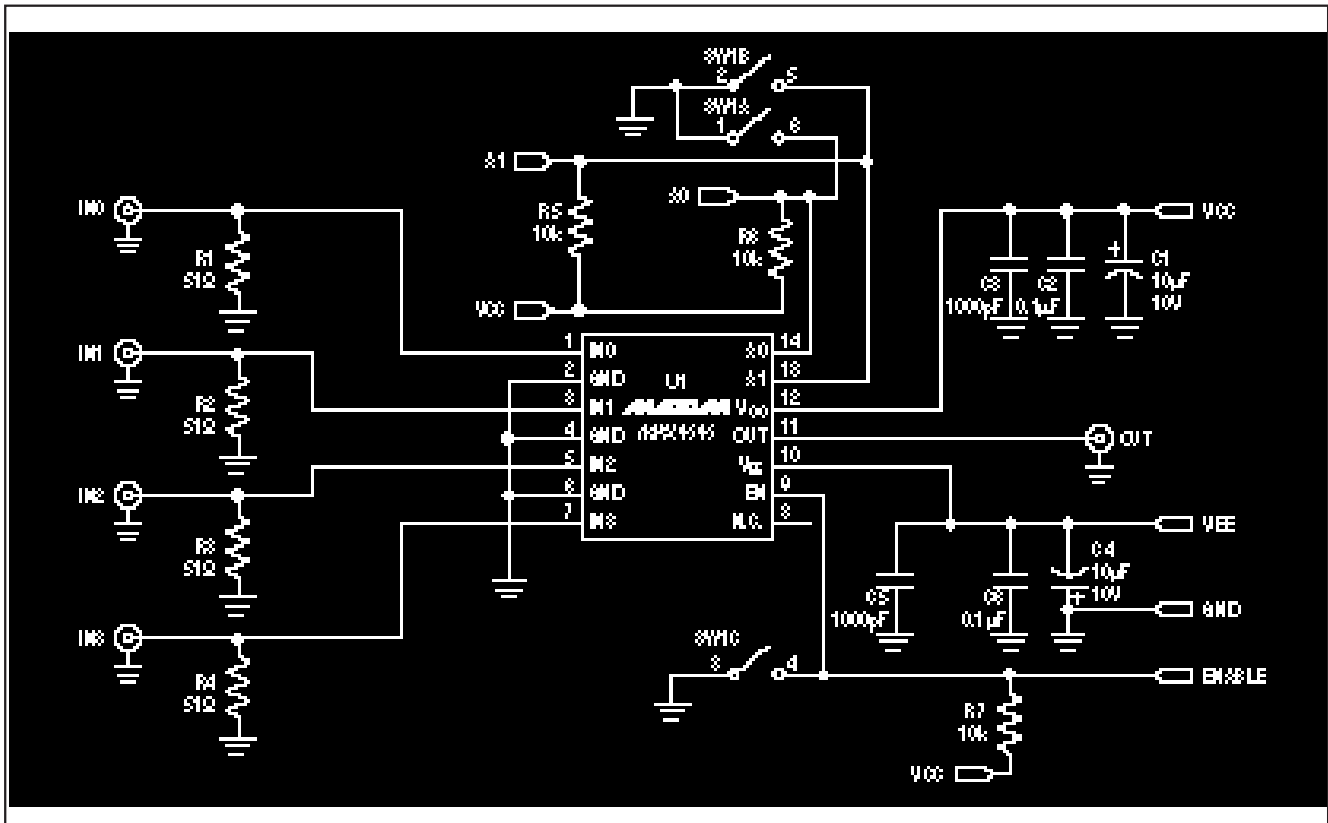

Figure 1. MAX4141 EV Kit Schematic Diagram

MAX4141 Evaluation Kit

Evaluates: MAX4141

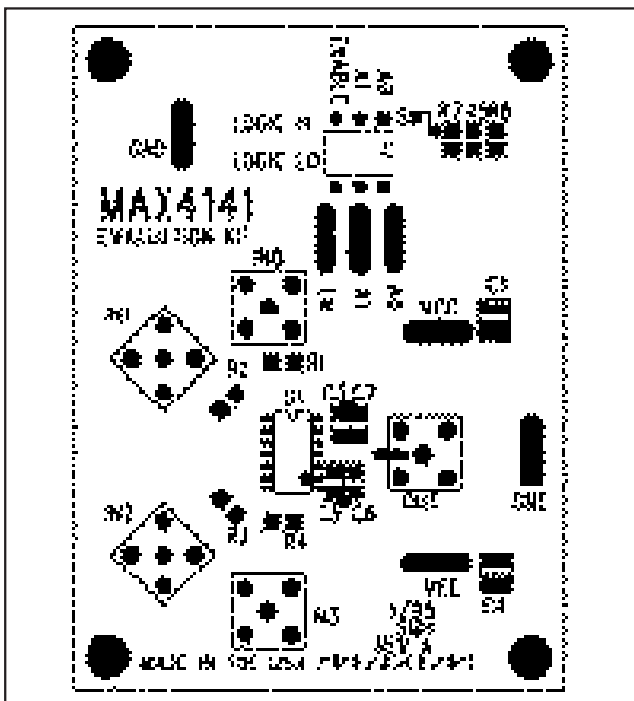

Figure 2. MAX4141 EV Kit Component Placement Guide—Component Side

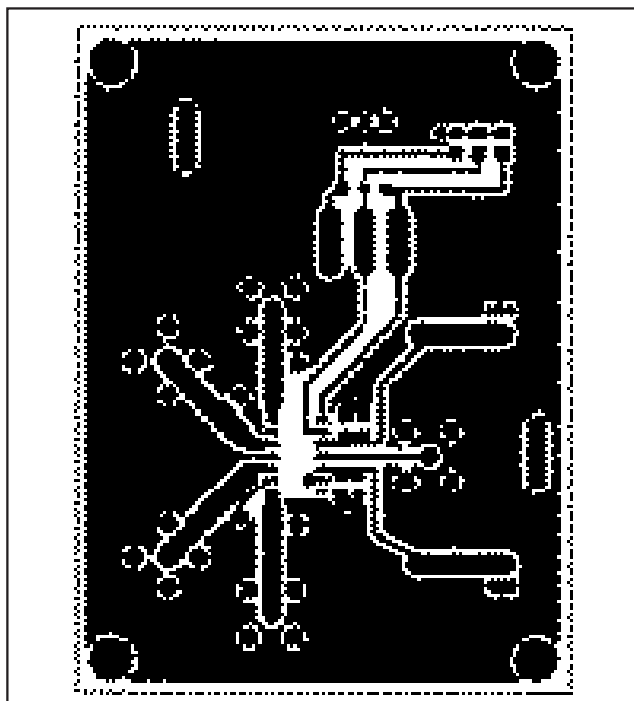

Figure 3. MAX4141 EV Kit PC Board Layout—Component Side

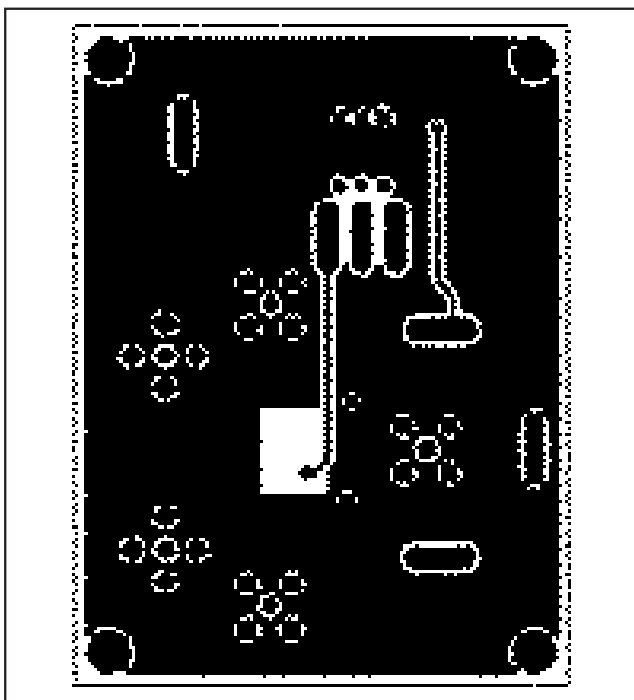

Figure 4. MAX4141 EV Kit PC Board Layout—Solder Side

