

Integrated Power Stage for 15 hp Motor Drives

- 15 hp (11kW) power output
- 380 - 480VAC; 50/60 Hz
- Available as complete system or sub-system assemblies

Power Assembly

- 3-phase rectifier bridge
- 3-phase ultrafast IGBT inverter
- NTC temperature sensor
- Pin-to-base plate isolation 2500 Vrms
- Easy-to-mount package
- Case temperature range -20°C to 95°C operational

Driver-Plus Board

- Capacitor filter with precharge current limit
- Isolated gate drive circuits
- On-board local power supply for gate driver and capacitor precharge control
- MOV surge suppression at input
- Isolated inverter current feedback
- Short circuit, earth/ground fault, over-temperature protection
- Input and output terminals; optional external brake
- Control interface connector

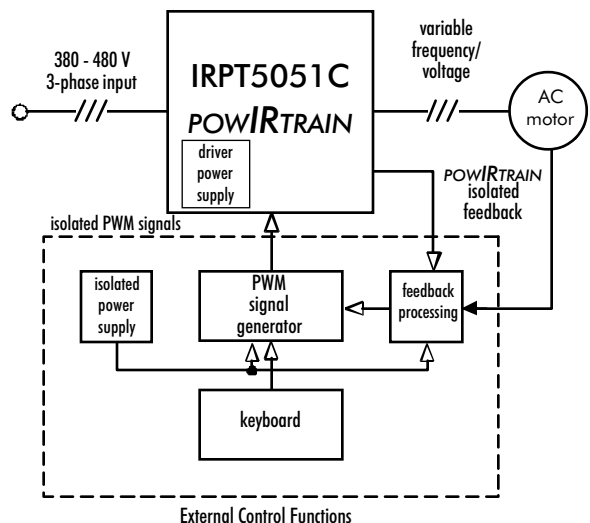
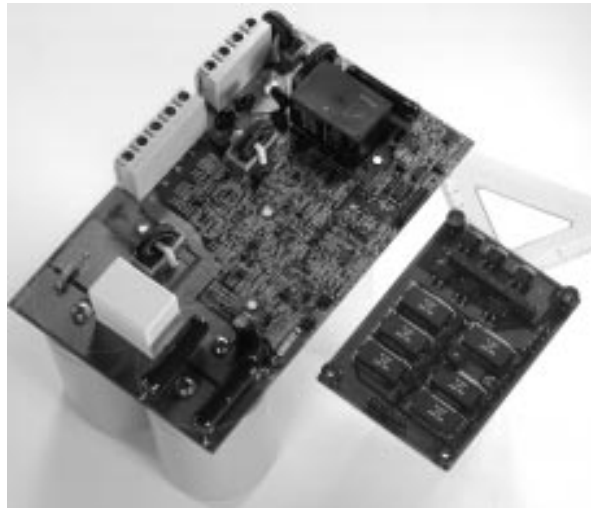

Figure 1. The IRPT5051C POWIRTRAIN within a motor control system

System Description

The IRPT5051C **POWIRTRAIN** provides the complete power conversion function for a 15hp (11kW) variable frequency AC motor controller. It contains a 3-phase input rectifier, DC link capacitor, 3-phase IGBT inverter, isolated gate drive circuits, shutdown protection, isolated trip and current feedback signals, and capacitor pre-charge function. Terminal blocks fitted to the **POWIRTRAIN** allow for end-user input and output connections.

Output power is pulse-width modulated (PWM) 3-phase, variable frequency, variable voltage controlled by externally generated user-provided PWM logic input signals, which control the inverter stage – IGBT switching. The PWM input signal terminals and the output feedback signals are optically isolated from the power circuit.

Figure 1 is a block diagram of the IRPT5051C **POWIRTRAIN** within an AC motor control system. Figure 4 shows the functions and architecture of the IRPT5051C.

The IRPT5051C combines a lower Insulated Metal Substrate (IMS) power board, containing the power semiconductors and a thermistor, with the Driver-Plus Board. The power assembly is designed to be mounted to a heat sink. Figure 2 shows the IRPT5051A power assembly.

The Driver-Plus Board interfaces electrically to the IRPT5051A power assembly via soldered connector pins. All external connections to the **POWIRTRAIN** are made to terminal blocks on the Driver-Plus Board (figure 3.)

The IRPT5051C **POWIRTRAIN** offers several benefits to the motor control manufacturer:

- It eliminates component selection, design layout, interconnection, gate drive, local power supply, thermal sensing, current sensing, and protection.
- It provides committed power semiconductor losses and junction temperatures.
- Parts inventory is reduced.
- Gate drive and protection circuits are designed to closely match the operating characteristics of the power semiconductors. This allows power losses to be minimized and power rating to be maximized to a greater extent than is possible by designing with individual components.
- Optimized layout for performance and efficiency is provided.
- Low inductance system reduces noise and snubber requirements.
- Manufacturing assembly is greatly simplified.

[POWIRTRAIN specifications and ratings are given for system input and output voltage and current, power losses and heat sink requirements over a range of operating conditions. POWIRTRAIN system ratings are verified by IR in final testing.]

The IRPT5051A IMS Power Assembly

The IRPT5051A Power Assembly, shown in figure 2, employs surface-mount 1600V rated D²Pak input rectifiers and surface-mount SMD-10 1200V IGBT Co-pack switches for the output

inverter. A thermistor is included in the inverter section for thermal sensing.

The power stage is designed to minimize inductance in the power path and reduce noise during inverter operation. The power level interfaces to the Driver-Plus Board through solder pins, minimizing assembly and alignment. The power assembly mounts to a heat sink with five screw mount positions, one in each corner and a fifth near the center to insure good thermal contact between the IMS and the heat sink. Wide copper traces on the IMS insure low impedance interconnects for the power components.



Figure 2. IRPT5051A Power Assembly

The IRPT5051D Driver-Plus Board

Figure 3 is a photograph of the IRPT5051D Driver-Plus Board containing the driver, sensing and protection functions. Figure 4 provides detailed functional block diagrams of the IRPT5051D.

The **switching power supply** delivers a nominal 18V DC output, referenced to the negative DC bus, N. This feeds the gate drive, relay control and under voltage (UV) circuits, which are optically isolated from the control input section, and therefore require their own local power source.

The **gate drive circuits** deliver on/off gate drive signals to the IGBTs' gates, corresponding with input PWM control signals IN1 through IN6.

The **PWM gate** normally allows the input PWM control signals to pass to the input opto-isolators of the gate drive circuits. The conduction periods of the inverter switches essentially mimic those demanded by the PWM input signals.

During power-up and power-down, or in the event of overcurrent (OI) or overtemperature (OT), the **latch** inhibits the PWM

gate, deactivating the gate drive circuits and shutting off the inverter.

The **relay control circuit** delivers an on/off signal via an opto-isolator to the relay driver which controls the relay (K1). The relay contact is open during power-up, inserting the resistor R in series with the DC bus capacitor and limiting the capacitor charging current. In normal operation, the relay contact is closed. If the AC line voltage falls below 300V or if one input phase is lost, or if the DC line voltage falls to less than 82% of the peak line voltage, the relay contact opens.

The **UV circuit** senses the voltage of the local power supply, and sends a signal via an opto-isolator to the latch in the event of undervoltage. The UV circuit normally activates the latch only during power-up and power-down, preventing the IGBTs from

being turned on when the local power supply voltage is too low for proper IGBT switching.

The **current signal processing circuit** receives inputs from current transformers connected in series with the input lines and the DC bus capacitor. The output of the current signal processing circuit, IFB, is essentially an isolated replica of the inverter input current. An isolated current feedback signal, I_{FB} , is provided as an output of the IRPT5051A. If the inverter current exceeds the trip level of 65A, I_{FB} also activates the latch.

The **thermistor** activates the latch if the temperature of the IMS substrate exceeds a set level. The 15V isolated power supply used to power the IRPT5051 should be the same as the one for the PWM generation, otherwise the protection functions will be disabled.

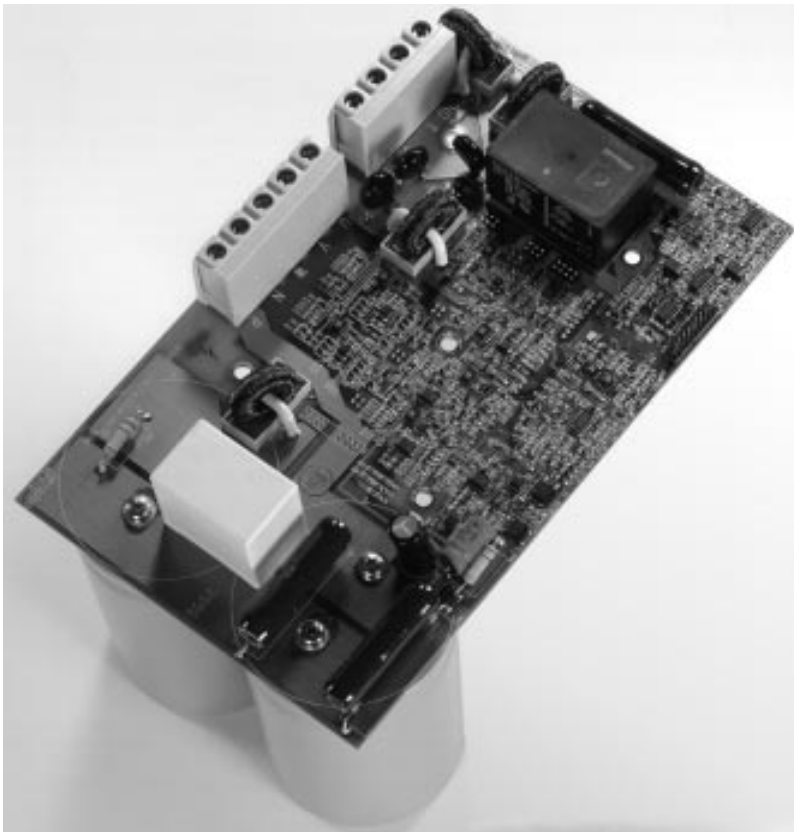

Figure 3. IRPT5051D Driver-Plus Board

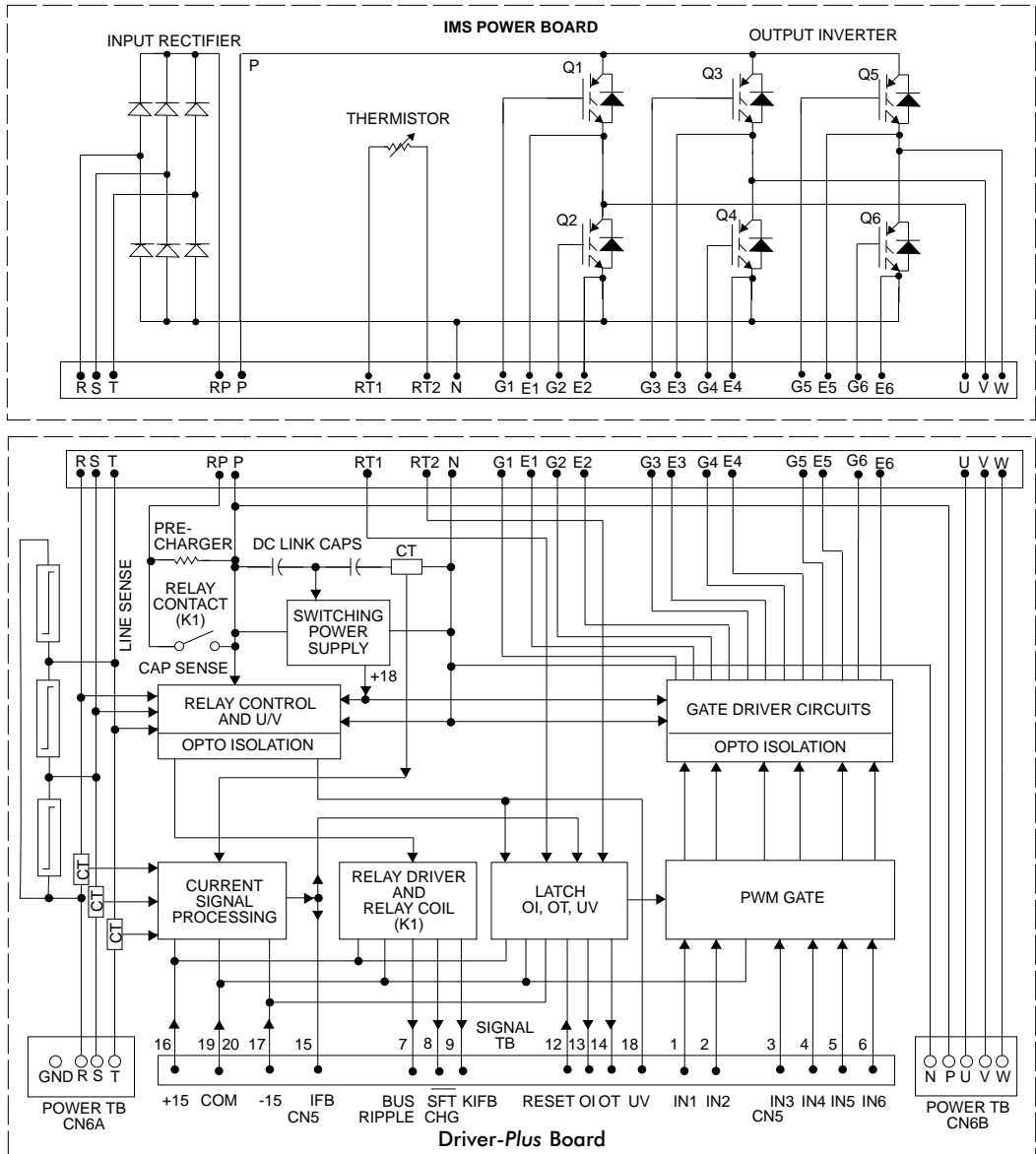

Figure 4. IRPT5051C Basic Architecture

Specifications

PARAMETER	VALUES	CONDITIONS
Input Power		
Voltage	380V -15% to 480V +10%, 3-phase	
Frequency	50 - 60Hz	
Input Current	40A rms 300 A peak	$T_A = 40^\circ\text{C}$, $R_{th SA} = 0.075^\circ\text{C/W}$ 10 ms half-cycle non-repetitive surge
Output Power		
Voltage	0 - 480V rms	defined by external PWM control
Nominal Motor hp (kW)	15hp (11kW)	$V_{in} = 440\text{VAC}$
Nominal Motor Current	25A rms	PWM frequency = 4kHz, $f_o = 60\text{Hz}$, $T_A = 40^\circ\text{C}$, $R_{th SA} = 0.075^\circ\text{C/W}$
DC Link		
DC link voltage	850V maximum	
Control Inputs		
Control Power	15V $\pm 5\%$, 200mA positive supply 15V $\pm 5\%$, 10mA, negative supply	
PWM input signals IN1 - IN6	15V, 10mA, $\pm 10\%$ (max rise/fall time 150nsec)	input signals uninhibited internally
Input resistance IN1 - IN6	720 Ω $\pm 5\%$	input signals inhibited internally
Pulse deadtime	2.5 μsecs , minimum	
Minimum input pulse duration	1.0 μsec	
Maximum pulse duration for each upper IGBT	20ms	
RESET	15V active high, CMOS input (min duration 1 μsec)	
SFT CHG	2 mA pull-down to energize relay (overrides internal control)	
Protection		
Output current trip level	65A peak, $\pm 10\%$	
Overtemperature trip level	100 $^\circ\text{C}$, $\pm 5\%$	
Ground current trip level	40A peak, $\pm 10\%$	
Short circuit shutdown time	1.5 μsec typical	output terminals shorted
Feedback Signals		
Current feedback signal, IFB	100mV/A $\pm 10\%$ max. DC offset 200mV	
Overcurrent trip signal, OI	active high, 15V CMOS	
Overtemp trip signal, OT	active high, 15V CMOS	
BUS RIPPLE	15V high 4.7k pull-up, <0.5V low at 1.0mA; high-to-low transition at $V_{bus} = 82\%$ peak of line voltage	
UV	15V high, 10k pull-up, during UV <0.5 low at 1mA with no UV	
Relay coil feedback, K1FB	15V high when relay coil energized; low when relay coil de-energized	
Capacitor Precharge		
DC bus capacitor precharge time	400msecs max	measured from input line closure; line voltage > 300V
Module		
Isolation Voltage	2500V _{RMS} , 60Hz, 1 minute	pin to baseplate isolation
Operating Case Temperature	-20 $^\circ\text{C}$ to 95 $^\circ\text{C}$	
Mounting Torque	5 N-m	M5 screw type
System Environment		
Ambient Operating Temp. Range	0 to 40 $^\circ\text{C}$	90%RH max. (non-condensing)
Storage Temp. range	-20 to 60 $^\circ\text{C}$	90%RH max. (non-condensing)

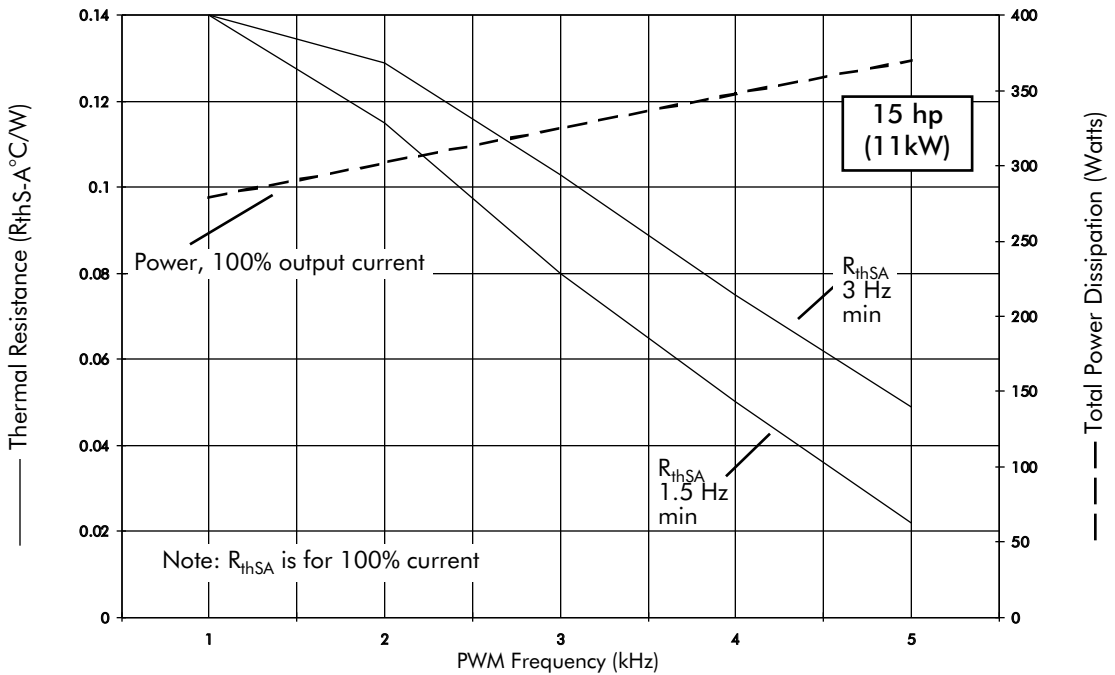

Figure 5a. 15hp/25A output Heat Sink Thermal Resistance and Power Dissipation vs. PWM Frequency

Operating Conditions: $V_{in}=440V_{rms}$, $MI=1.15$, $PF=0.8$, $T_A=40^{\circ}C$, Z_{thSA} limits temperature rise (ΔT_c) during 1 minute overload to $10^{\circ}C$

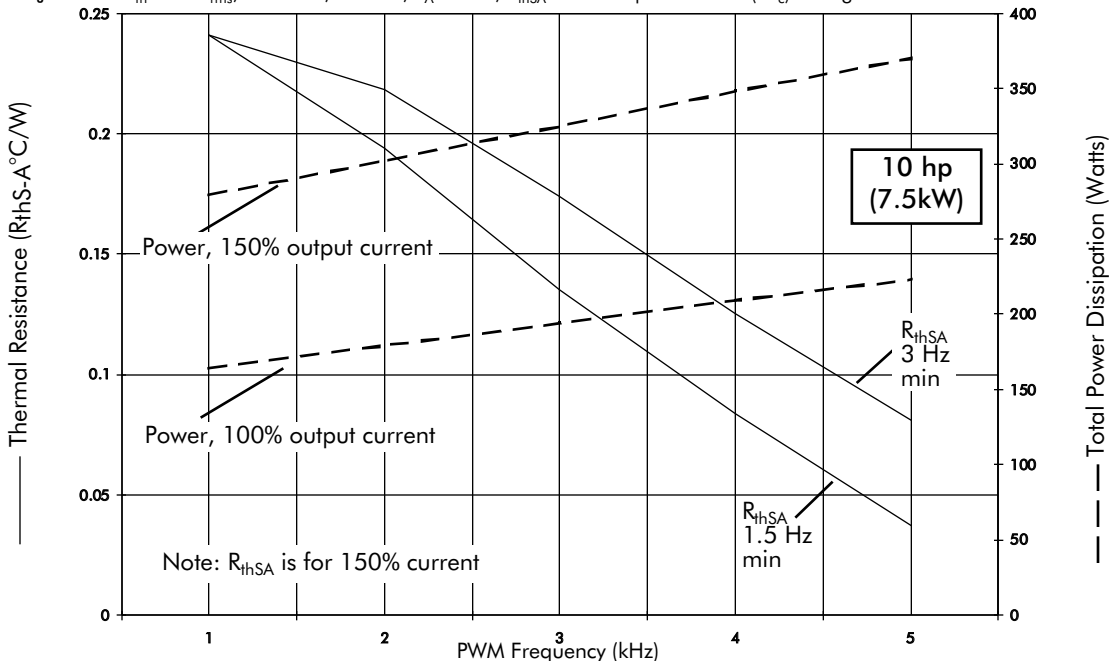

Figure 5b. 10hp/16.5A output Heat Sink Thermal Resistance and Power Dissipation vs. PWM Frequency

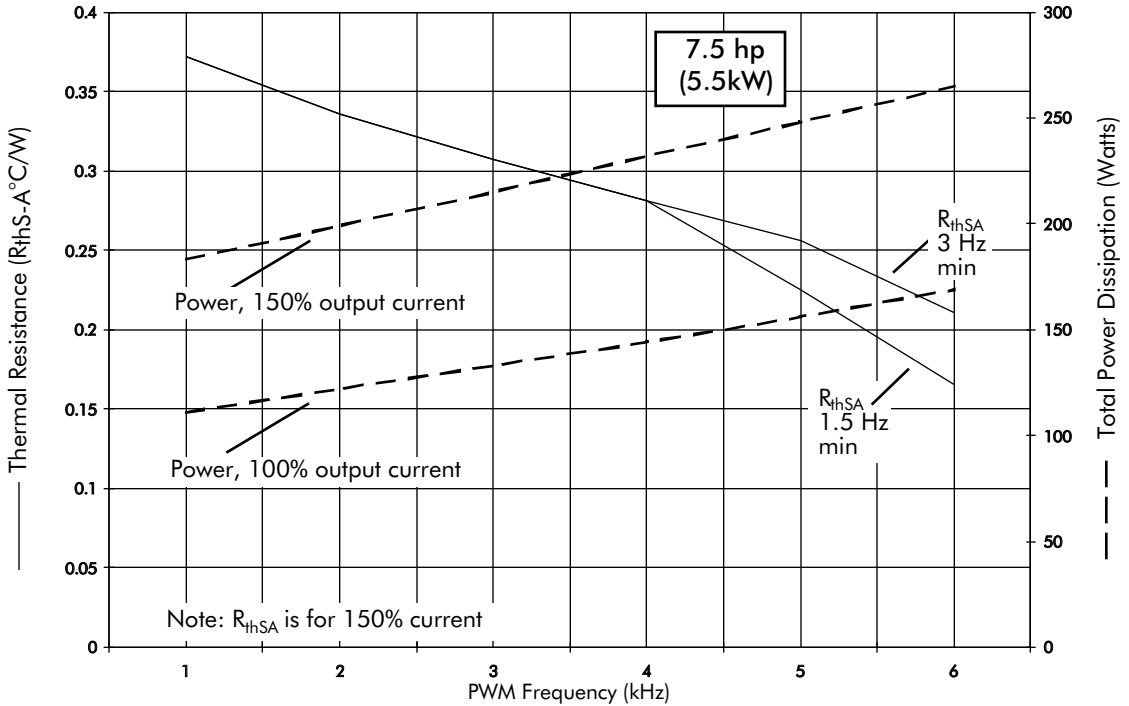

Figure 5c. 7.5hp/12A output Heat Sink Thermal Resistance and Power Dissipation vs. PWM Frequency

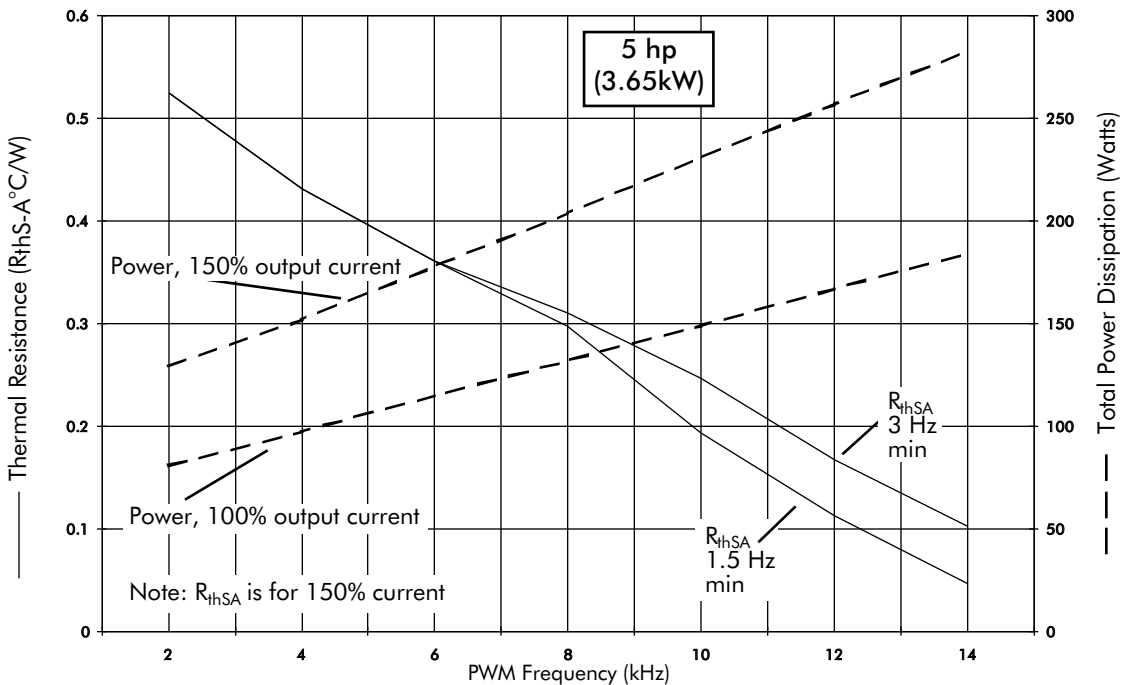

Figure 5d. 5hp/8.4A output Heat Sink Thermal Resistance and Power Dissipation vs. PWM Frequency

Mounting, Hookup and Application Instructions

Mounting

Unless supplied connected, first connect the IRPT5051D and the IRPT5051A power assembly.

1. Remove all particles and grit from the heat sink and power substrate.
2. Spread a .004" to .005" layer of silicone grease on the heat sink, covering the entire area that the power substrate will occupy.
3. Place the power substrate onto the heat sink with the mounting holes aligned and press it firmly into the silicone grease.
4. Place the 5 M5 mounting screws through the PCB and power substrate and into the heat sink and tighten with fingers.

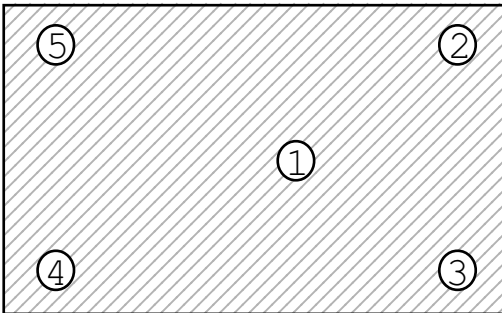

Figure 6. Power Assembly Mounting Screw Sequence

5. Tighten the screws to 2 Nm torque, according to the sequence shown below.
6. Re-tighten the screws to 4-5 Nm using the same sequence as in step 5.

Control Connections

All input and output control connections are made via a female connector to CN6.

Power Connections

3-phase input connections are made to terminals R,S and T. Inverter output terminal connections are made to terminals U,V and W.

Positive and negative dc bus connections are brought out to terminals P (positive) and N (negative). An external braking circuit can be connected across terminals P and N.

Logic Sequence During Power-Up

When 3-phase input power is first switched on, PWM inputs to the IRPT5051 must be inhibited until all the following logic conditions are met:

1. external 15V supply is established
2. UV feedback signal is low, indicating local power supply for gate drive circuits is established
3. K1FB signal is high, indicating capacitor precharge relay is energized.

When these conditions are simultaneously met, a 15V RESET pulse should be applied to the RESET input.

PWM input signals can now be released to the IRPT5051. The first PWM input signal to each of the lower IGBT inputs (IN2, IN4, IN6) should have at least 50µs duration, to allow the bootstrap capacitors to charge.

Logic Sequence During Power-Down

The following sequence is recommended for normal power down:

1. reduce motor speed to zero by PWM control
2. inhibit PWM inputs
3. disconnect main power.

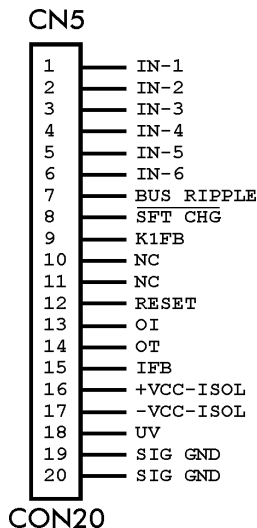

Figure 7a. Control Signal Connector

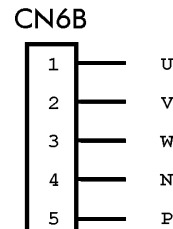
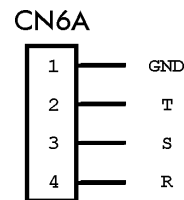
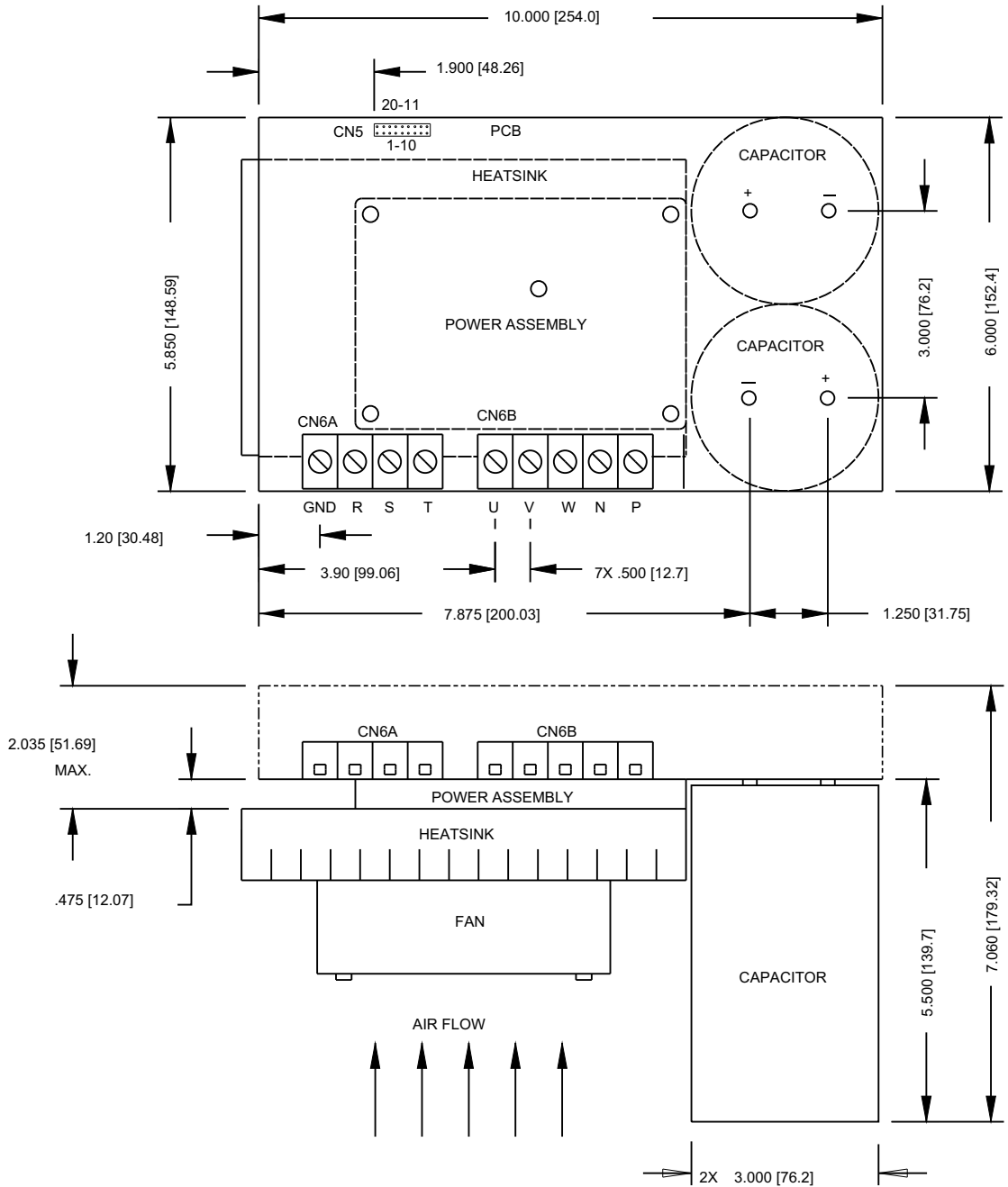

Figure 7b. Input and Output Terminal Blocks

IRPT5051D Mechanical Specifications

NOTE: Dimensions are in inches (millimeters)



IRPT5051

IRPT5051A Mechanical Specifications

NOTE: Dimensions are in inches (millimeters)

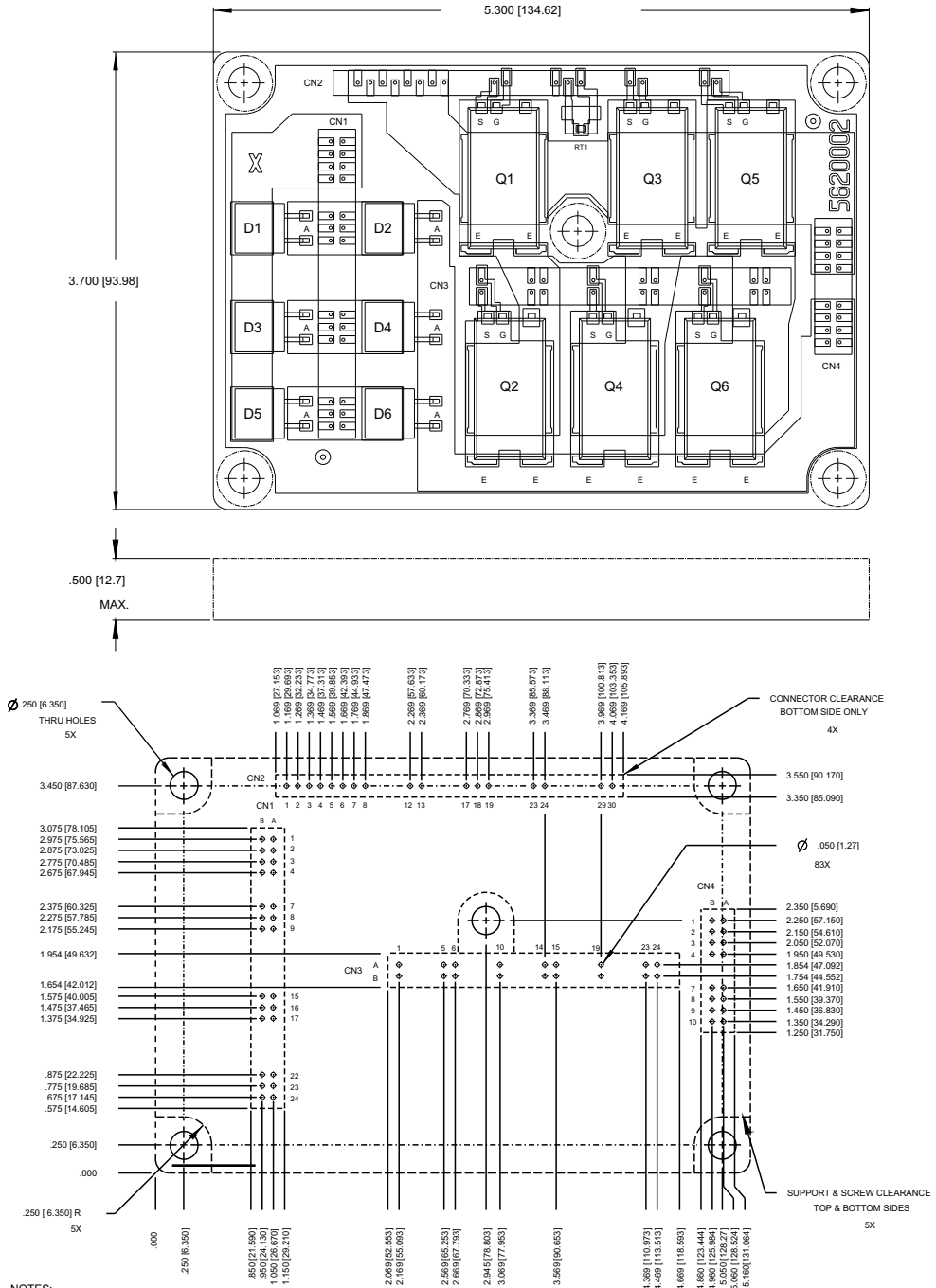

Part Number Identification and Ordering Instructions

IRPT5051A Power Assembly

IMS assembly incorporating 1600V input rectifiers in D²Paks, 1200V ultra-fast IGBT inverter with ultra-fast freewheeling diodes in SMD10 packages, along with a temperature sensing thermistor. The assembly is fully tested to meet all data sheet specifications.

IRPT5051C Complete *POWIRTRAIN*

Power Assembly (IRPT5051A) and Driver-*Plus* Board (IRPT5051D) pre-assembled and tested to meet all system specifications.

IRPT5051D Driver-*Plus* Board

Printed circuit board assembled with DC link capacitors, relay in-rush circuit, high power terminal blocks, surge suppression MOVs, IGBT gate drivers, protection circuitry and low power supply. The PCB is functionally tested with standard power assembly to meet all system specifications.

IRPT5051E Design Kit

Complete *POWIRTRAIN* (IRPT5051C) with full set of design documentation, including schematic diagram, bill of material, mechanical layout, schematic file, Gerber files and design tips.

Functional Information

Capacitor Precharge

When the input line voltage is first switched on, the charging current of the dc bus capacitors is limited by a 100 Ohm pre-charge resistor. When the bus capacitor has charged to approximately 85% of the peak line voltage, the capacitor pre-charge control circuit energizes the relay K1, bypassing the 100Ω pre-charge resistor, so long as the line voltage exceeds 300V rms and all three input phase voltages are present.

The relay feedback signal, K1FB is the voltage across the relay coil. This is 15V high when the relay is energized, and low when the relay is de-energized.

At start-up, the input PWM signals should be inhibited externally until K1FB becomes high, since if the inverter is operated before the pre-charge resistor is bypassed, this resistor will be overloaded.

The relay will drop out during operation if the dc bus voltage falls to less than 82% of the peak line voltage; if one or more input line voltages is lost; or if the input voltage falls below 300V. K1FB then becomes low and the PWM input signals should be inhibited externally to avoid overloading the pre-charge resistor.

The BUS RIPPLE feedback signal is high when the relay is de-energized, and low when it is energized. If one of the input phases is lost, the relay drops out and the BUS RIPPLE signal oscillates from high to low at line frequency.

The relay can be energized, if required, during single-phase operation by pulling down the SFT CHG terminal via an external open-collector transistor. The pull-down current is 2mA.

Discharging the Bus Capacitors

When the input power is switched off, the 'top' bus capacitor is discharged by a 10k resistor.

The 'lower' bus capacitor is discharged by a 10K resistor until its voltage reaches approximately 80V. Thereafter, discharge of the 'lower' capacitor is via a 110k resistor.

Undervoltage

The undervoltage circuit monitors the voltage of the local gate driver power supply and sends a high input signal during undervoltage which sets the latch and inhibits the PWM input signals.

This signal, brought out on pin 18 of CN5, is high during undervoltage. After it has gone low during power-up, a 15V RESET signal must be applied to reset the latch and allow the PWM input signals to pass to the gate drive circuits.

PWM input signals must be 15V positive logic. They must source 10mA into the opto-isolators of the IGBT gate driver circuits.

When inhibited by the internal PWM gate during power up, power down and fault conditions, each PWM input signal becomes loaded by a 720 Ohm resistor.

Maximum rise and fall times of the PWM input signals should be 150 nsecs.

Minimum dead time between outgoing and incoming PWM signals to the IGBTs in a given inverter leg should be 2.5µsecs. This is necessary to avoid inverter shoot-through.

The minimum duration of any PWM input pulse should be 1µsec.

Typical propagation delay between the PWM input and drive output at the gate of the IGBT is 300ns.

Bootstrap Supplies for the Gate Drive Circuits

The gate drive circuits for the upper IGBTs are powered from floating bootstrap capacitors. Each bootstrap capacitor is

charged via the corresponding lower IGBT when this is switched on.

Prior to initial application of the PWM input signals at start-up, the bootstrap capacitors are uncharged. Thus, an upper IGBT will not be turned on until after the corresponding lower IGBT has first been turned on to charge the bootstrap capacitor for the upper IGBT.

The minimum initial conduction period of each lower IGBT at start-up should be about 50µsec, to allow sufficient time for initial charging of the bootstrap capacitors.

In normal operation, the bootstrap capacitor maintains adequate gate drive voltage for a period of 20 milliseconds.

The maximum duration of the PWM input pulses (1N1, 1N3 and 1N5) should not exceed this period.

Peak line-to-line fault current in excess of a nominal value of 65A and peak line-to-ground current in excess of 40A sets the latch and internally inhibits the IGBT gate drive. The overcurrent feedback signal, OI, simultaneously goes high. Reaction time to a bolted short circuit is typically about 1µsec.

The LED1 lights up when any of the fault signals (UV, OI, OT) set the latch, indicating a fault condition. When the RESET signal is applied to the latch, the LED1 goes OFF if the fault that is setting the latch clears.

The internal PWM inhibit condition is cleared by applying 15V signal to the RESET terminal for a minimum period of 1 microsecond.

Overtemperature Trip

If the temperature of the IMS substrate exceeds a nominal value of 100°C, the overtemperature circuit sets the latch and internally inhibits the PWM input signals. The overtemperature feedback signal, OT, simultaneously goes high.

The internal PWM inhibit condition is cleared by applying a 15V signal to the RESET terminal for a minimum period of 1 microsecond.

Heat Sink Requirements

Figures 5a through 5d (pp. 6-7) show the thermal resistance of the heat sink required for various output power levels and PWM switching frequencies. Maximum total losses of the unit are also shown.

This data is based on the following key operating conditions:

- The maximum continuous combined losses of the rectifier and inverter occur at full pulse-width modulation. These maximum losses set the maximum continuous operating temperature of the heat sink.
- The maximum combined losses of the rectifier and inverter at full pulse-width modulation under overload set the incremental temperature rise of the heat sink during overload.
- The minimum output frequency at which full overload current is to be delivered sets the peak IGBT junction temperatures.

At low output frequency IGBT junction temperature tends to follow the instantaneous fluctuations of the output current. Thus, peak junction temperature rise increases as output frequency decreases.

Voltage Rise During Braking

The motor will feed energy back to the dc link during electrical braking, forcing the dc bus voltage to rise above the level defined by the input line voltage.

Deceleration of the motor must be controlled by appropriate PWM control to keep the dc bus voltage within the rated maximum value of 850V.

An external dissipative braking circuit, which keeps the bus voltage within the rated value, can be connected across the P and N terminals if required. □