

## 24-bit, 192kHz 6-Channel DAC with 1.7Vrms Line Driver

### DESCRIPTION

The WM8522 is a multi-channel audio DAC ideal for DVD and surround sound processing applications for home hi-fi, automotive and other audio visual equipment.

Three stereo 24-bit multi-bit sigma delta DACs are used with oversampling digital interpolation filters. Digital audio input word lengths from 16-32 bits and sampling rates from 8kHz to 192kHz are supported.

Each DAC channel has independent digital volume and mute control, and provides 1.7Vrms line drive capability from a 5V supply. This makes the device ideal for cost-sensitive consumer applications requiring high line drive audio outputs

The audio data interface supports I<sup>2</sup>S, left justified, right justified and DSP digital audio formats

The device is controlled via a 3 wire serial interface or directly using the hardware interface. These interfaces provide access to features including channel selection, volume controls, mutes, de-emphasis and power management facilities. The device is available in a 28-lead SSOP.

### FEATURES

- 6-Channel DAC with 1.7Vrms line driver from 5V analogue supply
- Audio performance
  - SNR 102dB ('A' weighted @ 48kHz)
  - THD -85dB (48kHz)
- DAC sampling frequency: 8kHz – 192kHz
- 3-Wire SPI serial or hardware control interface
- Programmable audio data interface modes
  - I<sup>2</sup>S, left, right justified or DSP
  - 16/20/24/32 bit word lengths
- Three independent stereo DAC outputs with independent digital volume controls
- Master or slave audio data interface
- 4.5V to 5.5V analogue, 2.7V to 3.6V digital supply operation
- Pin compatible with WM8766
- 28-lead SSOP package

### APPLICATIONS

- DVD Players
- Surround Sound AV Processors and Hi-Fi systems
- Automotive Audio

### BLOCK DIAGRAM

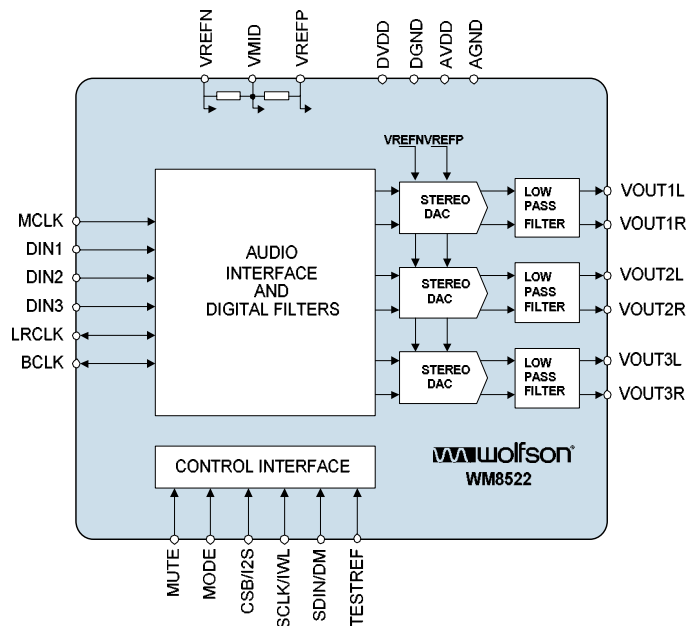

## TABLE OF CONTENTS

<b>DESCRIPTION .....</b>	<b>1</b>
<b>FEATURES.....</b>	<b>1</b>
<b>APPLICATIONS .....</b>	<b>1</b>
<b>BLOCK DIAGRAM .....</b>	<b>1</b>
<b>TABLE OF CONTENTS .....</b>	<b>2</b>
<b>PIN CONFIGURATION 28 LEAD SSOP .....</b>	<b>3</b>
<b>ORDERING INFORMATION .....</b>	<b>3</b>
<b>PIN DESCRIPTION – 28 LEAD SSOP .....</b>	<b>4</b>
<b>ABSOLUTE MAXIMUM RATINGS.....</b>	<b>5</b>
<b>RECOMMENDED OPERATING CONDITIONS .....</b>	<b>6</b>
<b>ELECTRICAL CHARACTERISTICS .....</b>	<b>6</b>
TERMINOLOGY .....	7
MASTER CLOCK TIMING .....	7
DIGITAL AUDIO INTERFACE – MASTER MODE .....	8
DIGITAL AUDIO INTERFACE – SLAVE MODE .....	9
MPU INTERFACE TIMING .....	10
<b>INTERNAL POWER ON RESET CIRCUIT .....</b>	<b>11</b>
<b>DEVICE DESCRIPTION .....</b>	<b>12</b>
INTRODUCTION .....	12
AUDIO DATA SAMPLING RATES.....	12
HARDWARE CONTROL MODES .....	13
DIGITAL AUDIO INTERFACE .....	15
POWERDOWN MODES .....	18
SOFTWARE CONTROL INTERFACE OPERATION.....	19
CONTROL INTERFACE REGISTERS .....	19
<b>REGISTER MAP.....</b>	<b>30</b>
<b>REGISTER MAP DESCRIPTION .....</b>	<b>31</b>
<b>DIGITAL FILTER CHARACTERISTICS .....</b>	<b>34</b>
<b>DAC FILTER RESPONSES .....</b>	<b>34</b>
DIGITAL DE-EMPHASIS CHARACTERISTICS.....	35
<b>APPLICATIONS INFORMATION .....</b>	<b>36</b>
RECOMMENDED EXTERNAL COMPONENTS.....	36
SUGGESTED ANALOGUE LOW PASS POST DAC FILTERS .....	37
<b>PACKAGE DIMENSIONS .....</b>	<b>38</b>
<b>IMPORTANT NOTICE .....</b>	<b>39</b>
ADDRESS: .....	39

**PIN CONFIGURATION 28 LEAD SSOP**

MODE	<input type="checkbox"/> 1 ●	28	<input type="checkbox"/> AVDD
MCLK	<input type="checkbox"/> 2	27	<input type="checkbox"/> AGND
BCLK	<input type="checkbox"/> 3	26	<input type="checkbox"/> VOUT3R
LRCLK	<input type="checkbox"/> 4	25	<input type="checkbox"/> VOUT3L
DVDD	<input type="checkbox"/> 5	24	<input type="checkbox"/> VOUT2R
DGND	<input type="checkbox"/> 6	23	<input type="checkbox"/> VOUT2L
DIN1	<input type="checkbox"/> 7	22	<input type="checkbox"/> VOUT1R
DIN2	<input type="checkbox"/> 8	21	<input type="checkbox"/> VOUT1L
DIN3	<input type="checkbox"/> 9	20	<input type="checkbox"/> NC
DNC	<input type="checkbox"/> 10	19	<input type="checkbox"/> NC
CSB/I2S	<input type="checkbox"/> 11	18	<input type="checkbox"/> VMID
SCLK/IWL	<input type="checkbox"/> 12	17	<input type="checkbox"/> VREFP
SDIN/DM	<input type="checkbox"/> 13	16	<input type="checkbox"/> VREFN
MUTE	<input type="checkbox"/> 14	15	<input type="checkbox"/> TESTREF

**ORDERING INFORMATION**

DEVICE	TEMPERATURE RANGE	PACKAGE	MOISTURE SENSITIVITY LEVEL	PEAK SOLDERING TEMPERATURE
WM8522GEDS/V	-25 to +85°C	28-lead SSOP (Pb-free)	MSL3	260°C
WM8522GEDS/RV	-25 to +85°C	28-lead SSOP (Pb-free, tape and reel)	MSL3	260°C

**Note:**

Reel quantity = 2,000

## PIN DESCRIPTION – 28 LEAD SSOP

PIN	NAME	TYPE	DESCRIPTION
1	MODE	Digital input	Control format selection 0 = Software control 1 = Hardware control
2	MCLK	Digital input	Master clock; 128, 192, 256, 384, 512 or 768fs (fs = word clock frequency)
3	BCLK	Digital input/output	Audio interface bit clock
4	LRCLK	Digital input/output	Audio left/right word clock
5	DVDD	Supply	Digital positive supply
6	DGND	Supply	Digital negative supply
7	DIN1	Digital input	DAC channel 1 data input
8	DIN2	Digital input	DAC channel 2 data input
9	DIN3	Digital input	DAC channel 3 data input
10	DNC	Do not connect	Do not connect
11	CSB/I2S	Digital input	Software Mode: Serial interface Latch signal Hardware Mode: Input Audio Data Format
12	SCLK/IWL	Digital input	Software Mode: Serial control interface clock Hardware Mode: Audio data input word length
13	SDIN/DM	Digital input	Software Mode: Serial interface data Hardware Mode: De-emphasis selection
14	MUTE	Digital input/output	DAC Zero Flag output or DAC mute input
15	TESTREF	Analogue output	Test reference
16	VREFN	Supply	DAC negative supply
17	VREFP	Supply	DAC positive reference supply
18	VMID	Analogue output	Midrail divider decoupling pin; 10uF external decoupling
19	NC	No connect	No internal connection
20	NC	No connect	No internal connection
21	VOUT1L	Analogue output	DAC channel 1 left output
22	VOUT1R	Analogue output	DAC channel 1 right output
23	VOUT2L	Analogue output	DAC channel 2 left output
24	VOUT2R	Analogue output	DAC channel 2 right output
25	VOUT3L	Analogue output	DAC channel 3 left output
26	VOUT3R	Analogue output	DAC channel 3 right output
27	AGND	Supply	Analogue negative supply and substrate connection
28	AVDD	Supply	Analogue positive supply

**Note:** Digital input pins have Schmitt trigger input buffers.

## ABSOLUTE MAXIMUM RATINGS

Absolute Maximum Ratings are stress ratings only. Permanent damage to the device may be caused by continuously operating at or beyond these limits. Device functional operating limits and guaranteed performance specifications are given under Electrical Characteristics at the test conditions specified.



ESD Sensitive Device. This device is manufactured on a CMOS process. It is therefore generically susceptible to damage from excessive static voltages. Proper ESD precautions must be taken during handling and storage of this device.

Wolfson tests its package types according to IPC/JEDEC J-STD-020B for Moisture Sensitivity to determine acceptable storage conditions prior to surface mount assembly. These levels are:

MSL1 = unlimited floor life at <30°C / 85% Relative Humidity. Not normally stored in moisture barrier bag.

MSL2 = out of bag storage for 1 year at <30°C / 60% Relative Humidity. Supplied in moisture barrier bag.

MSL3 = out of bag storage for 168 hours at <30°C / 60% Relative Humidity. Supplied in moisture barrier bag.

The Moisture Sensitivity Level for each package type is specified in Ordering Information.

CONDITION	MIN	MAX
Digital supply voltage	-0.3V	+5V
Analogue supply voltage	-0.3V	+7V
Voltage range digital inputs	DGND -0.3V	DVDD +0.3V
Voltage range analogue inputs	AGND -0.3V	AVDD +0.3V
Master Clock Frequency		38.462MHz
Operating temperature range, T <sub>A</sub>	-25°C	+85°C
Storage temperature after soldering	-65°C	+150°C

### Notes:

1. Analogue and digital grounds must always be within 0.3V of each other for normal operation of the device.

## RECOMMENDED OPERATING CONDITIONS

PARAMETER	SYMBOL	TEST CONDITIONS	MIN	TYP	MAX	UNIT
Digital supply range	DVDD		2.7		3.6	V
Analogue supply range	AVDD, VREFP		4.5		5.5	V
Ground	AGND, VREFN, DGND			0		V
Difference DGND to AGND			-0.3	0	+0.3	V

**Note:** Digital supply DVDD must never be more than 0.3V greater than AVDD for normal operation of the device.

## ELECTRICAL CHARACTERISTICS

### Test Conditions

AVDD, VREFP = 5V, DVDD = 3.3V, AGND, VREFN = 0V, DGND = 0V,  $T_A = +25^\circ\text{C}$ ,  $f_s = 48\text{kHz}$ , MCLK = 256fs.

PARAMETER	SYMBOL	TEST CONDITIONS	MIN	TYP	MAX	UNIT
<b>Digital Logic Levels (CMOS Levels)</b>						
Input LOW level	$V_{IL}$				$0.3 \times \text{DVDD}$	V
Input HIGH level	$V_{IH}$		$0.7 \times \text{DVDD}$			V
Output LOW	$V_{OL}$	$I_{OL}=1\text{mA}$			$0.1 \times \text{DVDD}$	V
Output HIGH	$V_{OH}$	$I_{OH}=-1\text{mA}$	$0.9 \times \text{DVDD}$			V
<b>Analogue Reference Levels</b>						
Reference Voltage	$V_{VMID}$			VREFP/2		V
Potential Divider Resistance	$R_{VMID}$	(VREFP to VMID) and (VMID to VREFN)		50		$\text{k}\Omega$
<b>DAC Performance (Load = 10k<math>\Omega</math>, 50pF)</b>						
0dBfs Full Scale Output Voltage			$1.6 \times \text{VREFP}/5$	$1.7 \times \text{VREFP}/5$	$1.8 \times \text{VREFP}/5$	V <sub>rms</sub>
SNR (Note 1,2,4)		A-weighted, @ $f_s = 48\text{kHz}$	95	102		dB
SNR (Note 1,2,4)		A-weighted @ $f_s = 96\text{kHz}$		101		dB
SNR (Note 1,2,4)		A-weighted @ $f_s = 192\text{kHz}$		101		dB
SNR (Note 1,2,4)		A-weighted @ $f_s = 48\text{kHz}$ , AVDD = 3.3V		101		dB
SNR (Note 1,2,4)		A-weighted @ $f_s = 96\text{kHz}$ , AVDD = 3.3V		99		dB
Dynamic Range (Note 2,4)	DNR	A-weighted, -60dB full scale input	95	102		dB
Total Harmonic Distortion (THD)		1kHz, 0dBfs		-85	-78	dB
Mute Attenuation		1kHz Input, 0dB gain		100		dB
DAC Channel Separation				100		dB
Power Supply Rejection Ratio	PSRR	1kHz 100mVpp		50		dB
		20Hz to 20kHz 100mVp-p		45		dB
<b>Supply Current</b>						
Analogue Supply Current		AVDD, VREFP = 5V		12		mA
Digital Supply Current		DVDD = 3.3V		10		mA

**Notes:**

1. Ratio of output level with 1kHz full scale input, to the output level with all zeros into the digital input, measured 'A' weighted.
2. All performance measurements done with 20kHz low pass filter, and where noted an A-weight filter. Failure to use such a filter will result in higher THD+N and lower SNR and Dynamic Range readings than are found in the Electrical Characteristics. The low pass filter removes out of band noise; although it is not audible it may affect dynamic specification values.
3. VMID decoupled with 10uF and 0.1uF capacitors (smaller values may result in reduced performance).

**TERMINOLOGY**

1. Signal-to-noise ratio (dB) - SNR is a measure of the difference in level between the full scale output and the output with no signal applied. (No Auto-zero or Automute function is employed in achieving these results).
2. Dynamic range (dB) - DNR is a measure of the difference between the highest and lowest portions of a signal. Normally a THD+N measurement at 60dB below full scale. The measured signal is then corrected by adding the 60dB to it. (e.g. THD+N @ -60dB= -32dB, DR= 92dB).
3. THD+N (dB) - THD+N is a ratio, of the rms values, of (Noise + Distortion)/Signal.
4. Stop band attenuation (dB) - Is the degree to which the frequency spectrum is attenuated (outside audio band).
5. Channel Separation (dB) - Also known as crosstalk. This is a measure of the amount one channel is isolated from the other. Normally measured by sending a full scale signal down one channel and measuring the other.
6. Pass-Band Ripple - Any variation of the frequency response in the pass-band region.

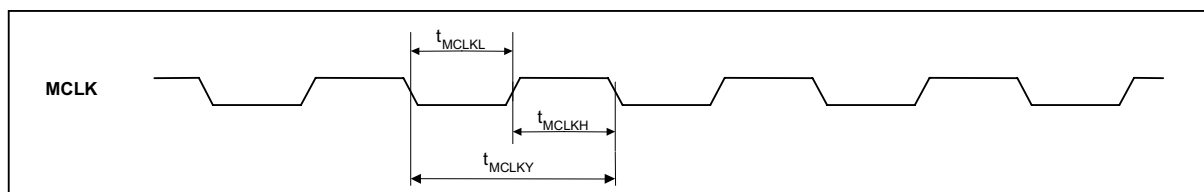
**MASTER CLOCK TIMING****Figure 1 DAC Master Clock Timing Requirements****Test Conditions**

AVDD, VREFP = 5V, DVDD = 3.3V, AGND, VREFN = 0V, DGND = 0V,  $T_A = +25^\circ\text{C}$ ,  $f_s = 48\text{kHz}$ , MCLK = 256fs unless otherwise stated.

PARAMETER	SYMBOL	TEST CONDITIONS	MIN	TYP	MAX	UNIT
<b>System Clock Timing Information</b>						
MCLK System clock pulse width high	$t_{MCLKH}$		11			ns
MCLK System clock pulse width low	$t_{MCLKL}$		11			ns
MCLK System clock cycle time	$t_{MCLKY}$		26		1000	ns
MCLK Duty cycle			40:60		60:40	
Power-saving mode activated		After MCLK stopped	2		10	$\mu\text{s}$
Normal mode resumed		After MCLK re-started	0.5		1	MCLK cycle

**Table 1 Master Clock Timing Requirements****Note:**

If MCLK period is longer than maximum specified above, power-saving mode is entered and DACs are powered down with internal digital audio filters being reset. In this power-saving mode, all registers will retain their values and can be accessed in the normal manner through the control interface. Once MCLK is restored, the DACs are automatically powered up, but a write to the volume update register bit is required to restore the correct volume settings.

DIGITAL AUDIO INTERFACE – MASTER MODE

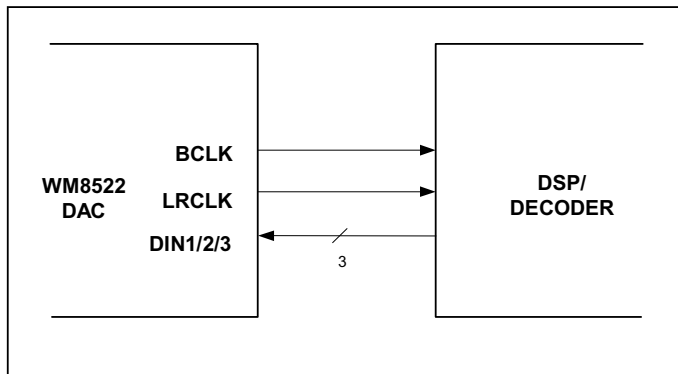

Figure 2 Audio Interface - Master Mode

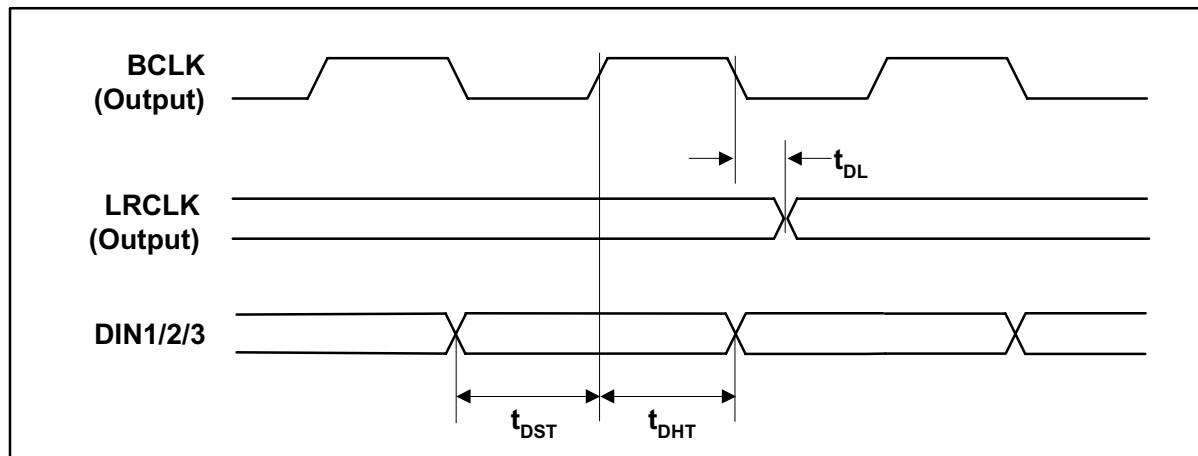

Figure 3 Digital Audio Data Timing – Master Mode

Test Conditions

AVDD, VREFP = 5V, DVDD = 3.3V, AGND, VREFN, DGND = 0V, T<sub>A</sub> = +25°C, Master Mode, fs = 48kHz, MCLK = 256fs unless otherwise stated.

PARAMETER	SYMBOL	TEST CONDITIONS	MIN	TYP	MAX	UNIT
<b>Audio Data Input Timing Information</b>						
LRCLK propagation delay from BCLK falling edge	t <sub>DL</sub>		0		10	ns
DIN1/2/3 setup time to BCLK rising edge	t <sub>DST</sub>		10			ns
DIN1/2/3 hold time from BCLK rising edge	t <sub>DHT</sub>		10			ns

Table 2 Digital Audio Data Timing – Master Mode



## DIGITAL AUDIO INTERFACE – SLAVE MODE

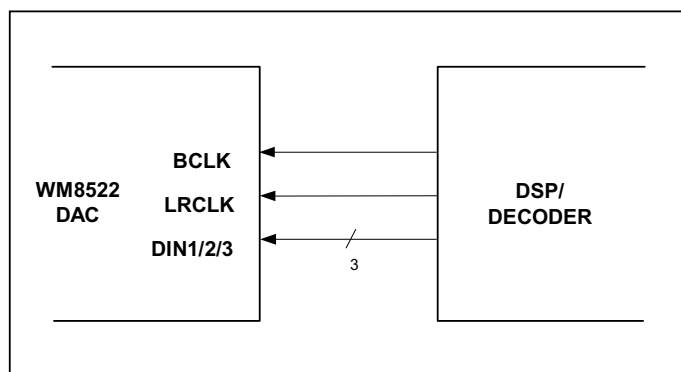

Figure 4 Audio Interface – Slave Mode

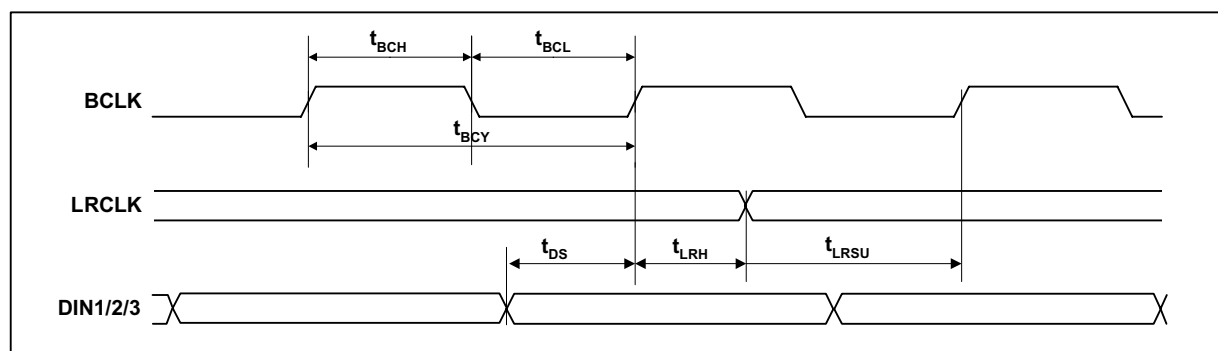

Figure 5 Digital Audio Data Timing – Slave Mode

## Test Conditions

AVDD = 5V, DVDD = 3.3V, AGND = 0V, DGND = 0V,  $T_A = +25^\circ\text{C}$ , Slave Mode,  $f_s = 48\text{kHz}$ , MCLK = 256fs unless otherwise stated.

PARAMETER	SYMBOL	TEST CONDITIONS	MIN	TYP	MAX	UNIT
<b>Audio Data Input Timing Information</b>						
BCLK cycle time	$t_{BCY}$		50			ns
BCLK pulse width high	$t_{BCH}$		20			ns
BCLK pulse width low	$t_{BCL}$		20			ns
LRCLK set-up time to BCLK rising edge	$t_{LRSU}$		10			ns
LRCLK hold time from BCLK rising edge	$t_{LRH}$		10			ns
DIN1/2/3 set-up time to BCLK rising edge	$t_{DS}$		10			ns
DIN1/2/3 hold time from BCLK rising edge	$t_{DH}$		10			ns

Table 3 Digital Audio Data Timing – Slave Mode

MPU INTERFACE TIMING

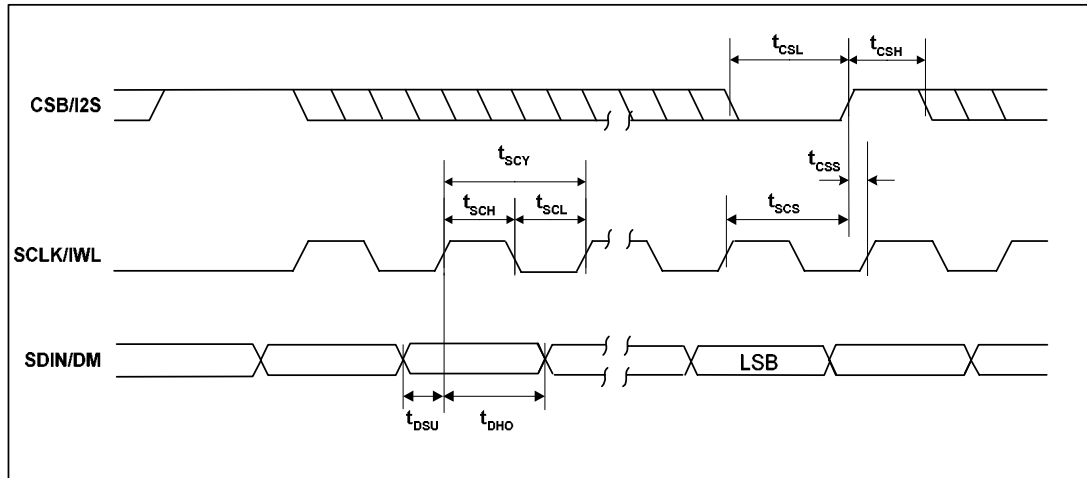
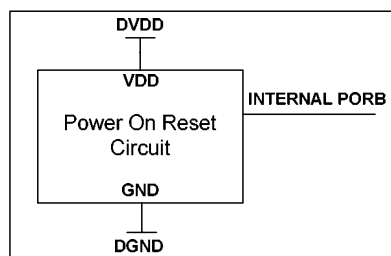

Figure 6 SPI Compatible Control Interface Input Timing

Test Conditions					
AVDD = 5V, DVDD = 3.3V, AGND, DGND = 0V, T <sub>A</sub> = +25°C, fs = 48kHz, MCLK = 256fs unless otherwise stated					
PARAMETER	SYMBOL	MIN	TYP	MAX	UNIT
SCLK/IWL rising edge to CSB/I2S rising edge	t <sub>SCS</sub>	60			ns
SCLK/IWL pulse cycle time	t <sub>SCY</sub>	80			ns
SCLK/IWL pulse width low	t <sub>SCL</sub>	30			ns
SCLK/IWL pulse width high	t <sub>SCH</sub>	30			ns
SDIN/DM to SCLK/IWL set-up time	t <sub>DSU</sub>	20			ns
SCLK/IWL to SDIN/DM hold time	t <sub>DHO</sub>	20			ns
CSB/I2S pulse width low	t <sub>CSL</sub>	20			ns
CSB/I2S pulse width high	t <sub>CSH</sub>	20			ns
CSB/I2S rising to SCLK/IWL rising	t <sub>CSS</sub>	20			ns

Table 4 3-Wire SPI Compatible Control Interface Input Timing Information

## INTERNAL POWER ON RESET CIRCUIT



**Figure 7 Internal Power on Reset Circuit Schematic**

The WM8522 includes an internal Power-On-Reset Circuit, as shown in Figure 7, which is used to reset the digital logic into a default state after power up. The POR circuit is powered from DVDD and monitors DVDD. It asserts PORB low if DVDD is below a minimum threshold.

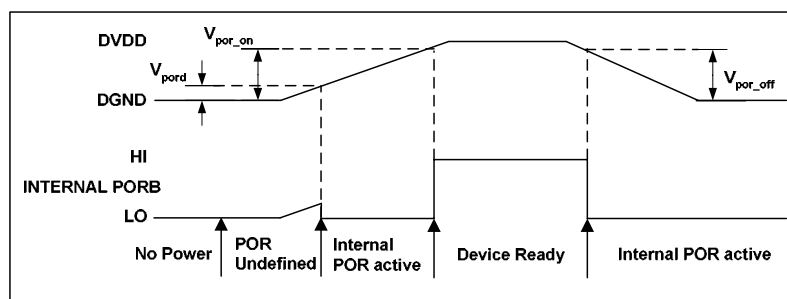

**Figure 8 Typical Power-Up Sequence**

Figure 8 shows a typical power-up sequence. When DVDD goes above the minimum threshold,  $V_{por\_on}$ , there is enough voltage for the circuit to guarantee PORB is asserted low and the chip is held in reset. In this condition, all writes to the control interface are ignored. When DVDD rises to  $V_{por\_on}$ , PORB is released high and all registers are in their default state and writes to the control interface may take place.

On power down, PORB is asserted low whenever DVDD drops below the minimum threshold  $V_{por\_off}$ .

SYMBOL	MIN	TYP	MAX	UNIT
$V_{por\_d}$	0.3	0.5	0.8	V
$V_{por\_on}$	1.3	1.7	2.0	V
$V_{por\_off}$	1.3	1.7	2.0	V

**Table 5 Typical POR Operation (typical values, not tested)**

## DEVICE DESCRIPTION

### INTRODUCTION

WM8522 is a complete 6-channel DAC including digital interpolation and decimation filters and switched capacitor multi-bit sigma delta DACs with digital volume controls on each channel and output smoothing filters. The device is capable of driving line levels up to 1.7V<sub>rms</sub> from a 5V analogue supply, minimising external filter component count.

The device is implemented as 3 separate stereo DACs in a single package and controlled by a single interface.

Each stereo DAC has its own data input DIN1/2/3. DAC word clock LRCLK, DAC bit clock BCLK and DAC master clock MCLK are shared between them.

The Audio Interface may be configured to operate in either master or slave mode. In Slave mode, LRCLK and BCLK are all inputs. In Master mode, LRCLK and BCLK are all outputs.

Each DAC has its own digital volume control that is adjustable in 0.5dB steps. The digital volume controls may be operated independently. In addition, a zero cross detect circuit is provided for each DAC for the digital volume controls. The digital volume control detects a transition through the zero point before updating the volume. This minimises audible clicks and 'zipper' noise as the gain values change.

Control of internal functionality of the device is by 3-wire serial or pin programmable control interface. The software control interface may be asynchronous to the audio data interface as control data will be re-synchronised to the audio processing internally.

Operation using master clocks of 128fs, 192fs, 256fs, 384fs, 512fs or 768fs is provided for the DAC. In Slave mode selection between clock rates is automatically controlled. In master mode, the sample rate is set by control bit DACRATE. Audio sample rates (fs) from less than 8ks/s up to 192ks/s are allowed for the DAC, provided the appropriate master clock is input.

The audio data interface supports right justified, left justified and I<sup>2</sup>S interface formats along with a highly flexible DSP serial port interface.

### AUDIO DATA SAMPLING RATES

In a typical digital audio system there is only one central clock source producing a reference clock to which all audio data processing is synchronised. This clock is often referred to as the audio system's Master Clock. The external master system clock can be applied directly through the DAC MCLK input pin(s) with no software configuration necessary.

The DAC master clock for WM8522 supports audio sampling rates from 128fs to 768fs, where fs is the audio sampling frequency (LRCLK) typically 32kHz, 44.1kHz, 48kHz, 96kHz or 192kHz. The master clock is used to operate the digital filters and the noise shaping circuits.

In Slave mode the WM8522 has a master clock detection circuit that automatically determines the relationship between the system clock frequency and the sampling rate (to within +/- 32 master clocks). If there is a greater than 32 clocks error the interface defaults to 768fs mode. The WM8522 is tolerant of phase variations or jitter on the master clock. Table 6 shows the typical master clock frequency inputs for the WM8522.

The signal processing for the WM8522 typically operates at an oversampling rate of 128fs. The exception to this is for operation with a 128/192fs system clock, e.g. for 192kHz operation, when the oversampling rate is 64fs.

SAMPLING RATE (LRCLK)	System Clock Frequency (MHz)					
	128fs	192fs	256fs	384fs	512fs	768fs
32kHz	4.096	6.144	8.192	12.288	16.384	24.576
44.1kHz	5.6448	8.467	11.2896	16.9340	22.5792	33.8688
48kHz	6.144	9.216	12.288	18.432	24.576	36.864
96kHz	12.288	18.432	24.576	36.864	Unavailable	Unavailable
192kHz	24.576	36.864	Unavailable	Unavailable	Unavailable	Unavailable

Table 6 System Clock Frequencies Versus Sampling Rate

## HARDWARE CONTROL MODES

When the MODE pin is held high, the following hardware modes of operation are available.

### MUTE AND AUTOMUTE OPERATION

In both hardware and software modes, MUTE controls the selection of MUTE directly, and can be used to enable and disable the automute function. This pin becomes an output when left floating and indicates infinite ZERO detect (IZD) has been detected.

	DESCRIPTION
0	Normal Operation
1	Mute DAC channels
Floating	Enable IZD, MUTE becomes an output to indicate when IZD occurs. L=IZD not detected, H=IZD detected.

Table 7 Mute and Automute Control

Figure 9 shows the application and release of MUTE whilst a full amplitude sinusoid is being played at 48kHz sampling rate. When MUTE (lower trace) is asserted, the output (upper trace) begins to decay exponentially from the DC level of the last input sample. The output will decay towards  $V_{MID}$  with a time constant of approximately 64 input samples. When MUTE is de-asserted, the output will restart almost immediately from the current input sample.

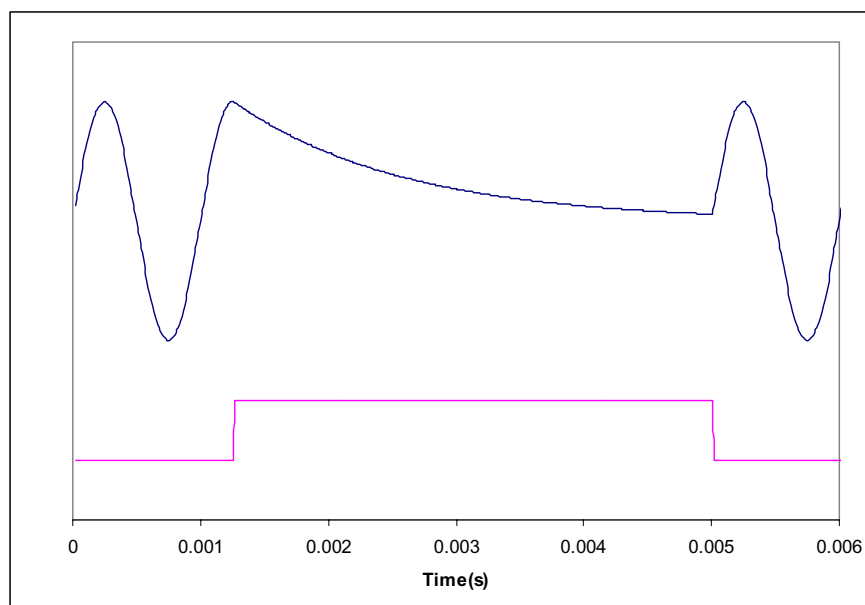

Figure 9 Application and Release of Soft Mute

In hardware mode (MODE pin set high) the MUTE pin becomes a bi-directional pin. Therefore if it is driven low the device will never softmute. If it is driven high then all channels will softmute immediately.

However if the pin is connected to a high impedance, or left floating, then when all three internal zero flags are raised the WM8522 will also drive a weak logic high signal on the MUTE pin (output impedance 10kOhms) which can be used to drive an external device.

It is not possible to perform analogue mute in Hardware mode.

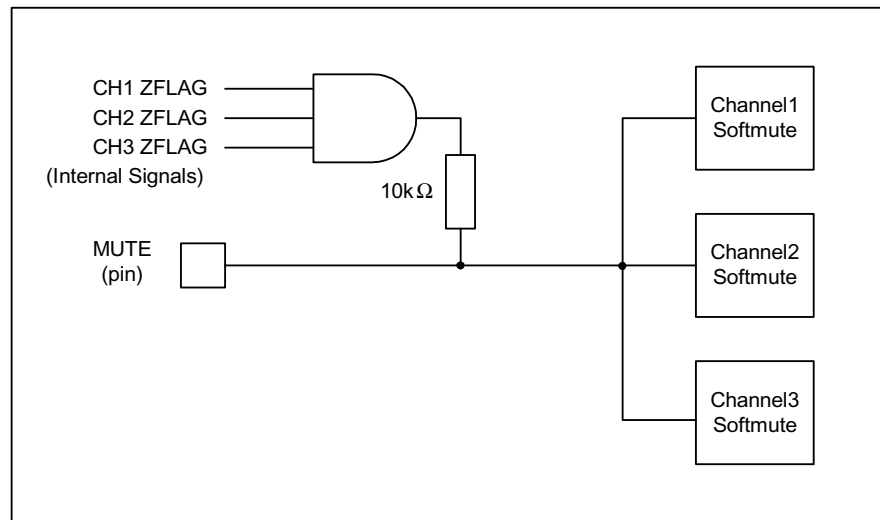

Figure 10 MUTE Logic in Hardware Mode

### INPUT FORMAT SELECTION

In hardware mode, CSB/I2S and SCLK/IWL become input controls for selection of input data format type and input data word length for the DAC.

CSB/I2S	SCLK/IWL	INPUT DATA MODE
0	0	24-bit right justified
0	1	20-bit right justified
1	0	16-bit I <sup>2</sup> S
1	1	24-bit I <sup>2</sup> S

Table 8 Input Format Selection

#### Note:

In 24 bit I<sup>2</sup>S mode, any width of 24 bits or less is supported provided that the left/right clocks (LRCLK) are high for a minimum of 24 bit clocks (BCLK) and low for a minimum of 24 bit clocks. If exactly 32 bit clocks occur in one left/right clock (16 high, 16 low) the chip will auto detect and run a 16 bit data mode.

### DE-EMPHASIS CONTROL

In hardware mode, the SDIN/DM pin becomes an input control for selection of de-emphasis filtering to be applied.

SDIN/DM	DE-EMPHASIS
0	Off
1	On

Table 9 De-emphasis Control

## DIGITAL AUDIO INTERFACE

### MASTER AND SLAVE MODES

The audio interface operates in either Slave or Master mode, selectable using the MS control bit. In both Master and Slave modes DIN1/2/3 are always inputs to the WM8522.

In Slave mode, LRCLK and BCLK are inputs to the WM8522 DIN1/2/3 and LRCLK are sampled by the WM8522 on the rising edge of BCLK.

By setting the control bit BCP the polarity of BCLK may be reversed so that DIN1/2/3 and LRCLK are sampled on the falling edge of BCLK.

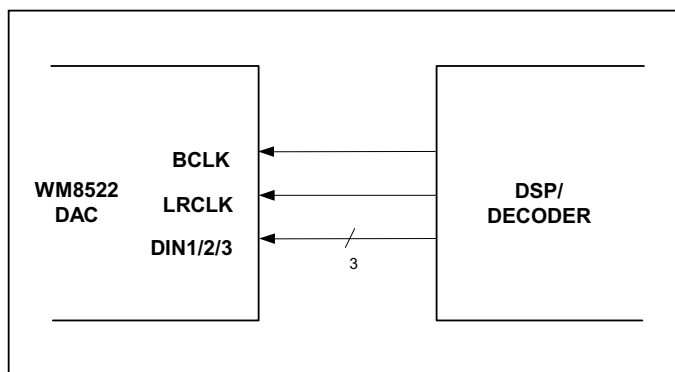

Figure 11 Slave Mode

In Master mode, LRCLK and BCLK are outputs from the WM8522 (Figure 12). LRCLK and BCLK are generated by the WM8522. DIN1/2/3 are sampled by the WM8522 on the rising edge of BCLK.

By setting control bit BCP the polarity of BCLK may be reversed so that DIN1/2/3 are sampled on the falling edge of BCLK.

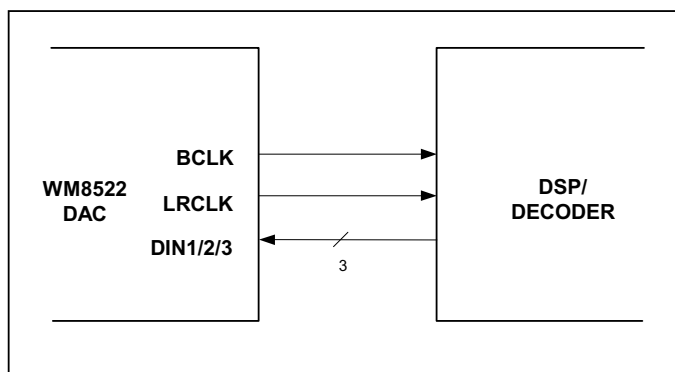

Figure 12 Master Mode

## AUDIO INTERFACE FORMATS

Audio data is applied to the internal DAC filters via the Digital Audio Interface. 5 popular interface formats are supported:

- Left Justified mode
- Right Justified mode
- I<sup>2</sup>S mode
- DSP mode A
- DSP mode B

All 5 formats send the MSB first and support word lengths of 16, 20, 24 and 32 bits, with the exception of 32 bit right justified mode, which is not supported.

In left justified, right justified and I<sup>2</sup>S modes, the digital audio interface receives DAC data on the DIN1/2/3 inputs. Audio data for each stereo channel is time multiplexed with LRCLK indicating whether the left or right channel is present. LRCLK is also used as a timing reference to indicate the beginning or end of the data words.

In left justified, right justified and I<sup>2</sup>S modes, the minimum number of BCLKs per LRCLK period is 2 times the selected word length. LRCLK must be high for a minimum of word length BCLKs and low for a minimum of word length BCLKs. Any mark to space ratio on LRCLK is acceptable provided the above requirements are met.

In DSP modes A or B, all 6 DAC channels are time multiplexed onto DIN1. LRCLK is used as a frame sync signal to identify the MSB of the first word. The minimum number of BCLKs per LRCLK period is 6 times the selected word length. Any mark to space ratio is acceptable on LRCLK provided the rising edge is correctly positioned.

### LEFT JUSTIFIED MODE

In left justified mode, the MSB of DIN1/2/3 is sampled by the WM8522 on the first rising edge of BCLK following a LRCLK transition. LRCLK is high during the left samples and low during the right samples, see Figure 13.

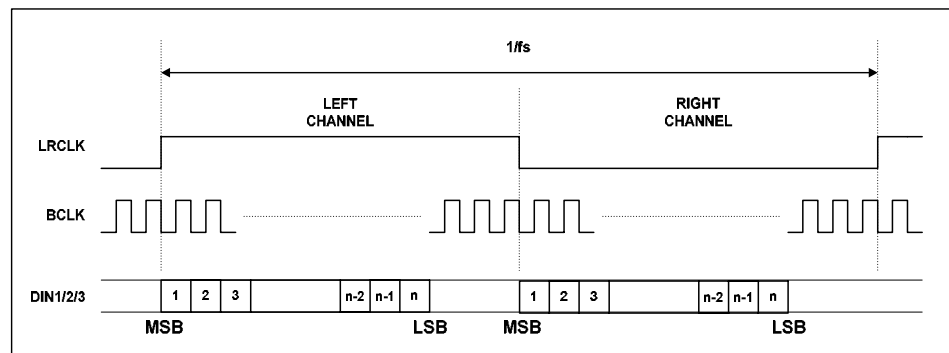

Figure 13 Left Justified Mode Timing Diagram



### RIGHT JUSTIFIED MODE

In right justified mode, the LSB of DIN1/2/3 is sampled by the WM8522 on the rising edge of BCLK preceding a LRCLK transition. LRCLK are high during the left samples and low during the right samples, see Figure 14.

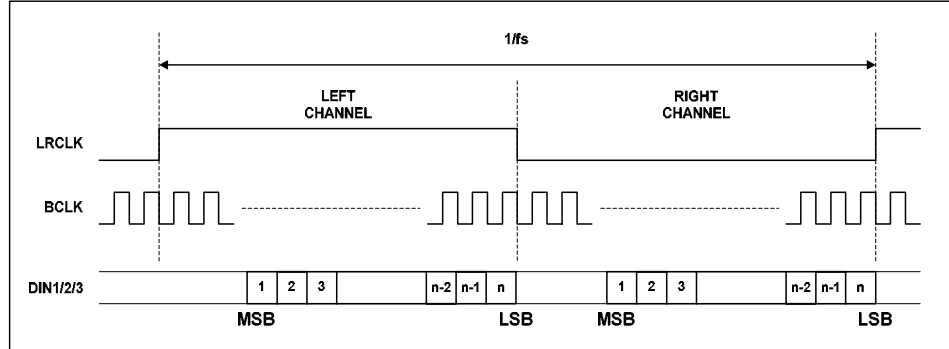

Figure 14 Right Justified Mode Timing Diagram

### I<sup>2</sup>S MODE

In I<sup>2</sup>S mode, the MSB of DIN1/2/3 is sampled by the WM8522 on the second rising edge of BCLK following a LRCLK transition. LRCLK are low during the left samples and high during the right samples.

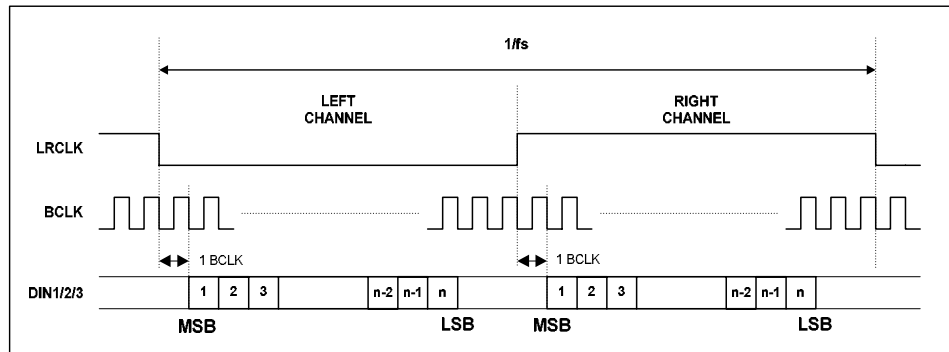
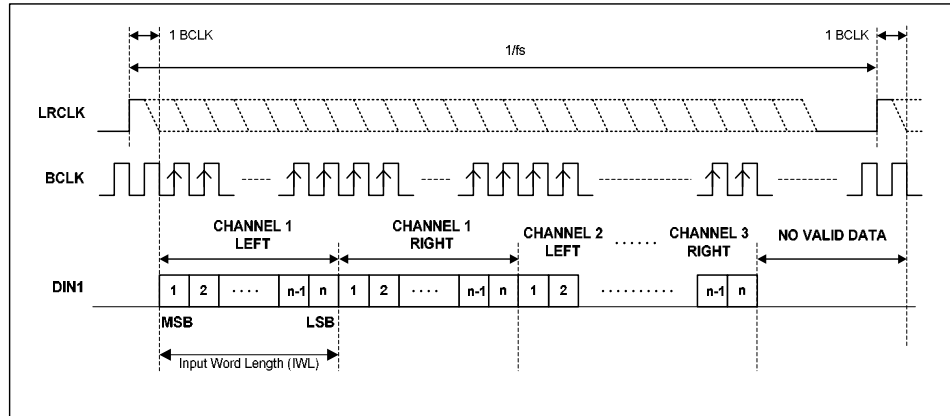

Figure 15 I<sup>2</sup>S Mode Timing Diagram

**DSP MODE A**

In DSP mode A, the MSB of DAC channel 1 left data is sampled by the WM8522 on the second rising edge on BCLK following a LRCLK rising edge. DAC channel 1 right and DAC channels 2 and 3 data follow DAC channel 1 left data (Figure 16).



**Figure 16 DSP Mode A Timing Diagram – DAC Data Input**

**DSP MODE B**

In DSP mode B, the MSB of DAC channel 1 left data is sampled by the WM8522 on the first BCLK rising edge following a LRCLK rising edge. DAC channel 1 right and DAC channels 2 and 3 data follow DAC channel 1 left data (Figure 17).

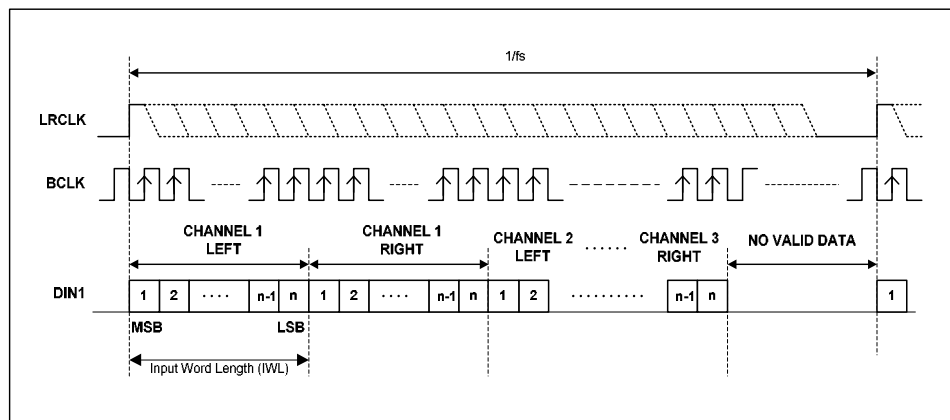

**Figure 17 DSP Mode B Timing Diagram – DAC Data Input**

In both DSP modes A and B, DACL1 is always sent first, followed immediately by DACR1 and the data words for the other 6 channels. No BCLK edges are allowed between the data words. The word order is DAC1 left, DAC1 right, DAC2 left, DAC2 right, DAC3 left, DAC3 right.

**POWERDOWN MODES**

The WM8522 has powerdown control bits allowing specific parts of the WM8522 to be powered off when not being used. The three stereo DACs each have a separate powerdown control bit, DACPD[2:0] allowing individual stereo DACs to be powered off when not in use. Setting DACPD[2:0] will powerdown everything except the reference VMID may be powered down by setting PDWN. Setting PDWN will override all other powerdown control bits. It is recommended that the DACs are powered down before setting PDWN.

## SOFTWARE CONTROL INTERFACE OPERATION

The WM8522 is controlled using a 3-wire serial interface in software mode or pin programmable in hardware mode.

The control mode is selected by the state of the MODE pin.

### 3-WIRE (SPI COMPATIBLE) SERIAL CONTROL MODE

SDIN/DM is used for the program data, SCLK/IWL is used to clock in the program data and CSB/I2S is used to latch the program data. SDIN/DM is sampled on the rising edge of SCLK/IWL. The 3-wire interface protocol is shown in Figure 18.

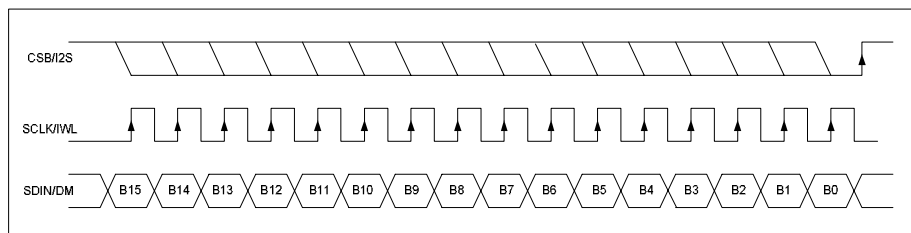

**Figure 18 3-Wire SPI Compatible Interface**

1. B[15:9] are Control Address Bits
2. B[8:0] are Control Data Bits
3. CSB/I2S is edge sensitive – the data is latched on the rising edge of CSB/I2S.

## CONTROL INTERFACE REGISTERS

### ATTENUATOR CONTROL MODE

Setting the ATC register bit causes the left channel attenuation settings to be applied to both left and right channel DACs from the next audio input sample. No update to the attenuation registers is required for ATC to take effect.

REGISTER ADDRESS	BIT	LABEL	DEFAULT	DESCRIPTION
0000010 DAC Channel Control	3	ATC	0	Attenuator Control Mode: 0: Right channels use right attenuations 1: Right channels use left attenuations

**DAC OUTPUT CONTROL**

The DAC output control word determines how the left and right inputs to the audio Interface are applied to the left and right DACs:

REGISTER ADDRESS	BIT	LABEL	DEFAULT	DESCRIPTION		
0000010 DAC Control	8:5	PL[3:0]	1001	PL[3:0]	Left Output	Right Output
				0000	Mute	Mute
				0001	Left	Mute
				0010	Right	Mute
				0011	(L+R)/2	Mute
				0100	Mute	Left
				0101	Left	Left
				0110	Right	Left
				0111	(L+R)/2	Left
				1000	Mute	Right
				1001	Left	Right
				1010	Right	Right
				1011	(L+R)/2	Right
				1100	Mute	(L+R)/2
				1101	Left	(L+R)/2
				1110	Right	(L+R)/2
1111	(L+R)/2	(L+R)/2				

**DAC DIGITAL AUDIO INTERFACE CONTROL REGISTER**

Interface format is selected via the FMT[1:0] register bits:

REGISTER ADDRESS	BIT	LABEL	DEFAULT	DESCRIPTION
0000011 Interface Control	1:0	FMT [1:0]	00	Interface Format Select: 00 : Right justified mode 01: Left justified mode 10: I <sup>2</sup> S mode 11: DSP modes A or B

In left justified, right justified or I<sup>2</sup>S modes, the LRP register bit controls the polarity of LRCLK. If this bit is set high, the expected polarity of LRCLK will be the opposite of that shown in Figure 13, Figure 14 and Figure 15. Note that if this feature is used as a means of swapping the left and right channels, a 1 sample phase difference will be introduced. In DSP modes, the LRP register bit is used to select between modes A and B.

REGISTER ADDRESS	BIT	LABEL	DEFAULT	DESCRIPTION
0000011 Interface Control	2	LRP	0	In left/right/I <sup>2</sup> S Modes: LRCLK Polarity (normal) 0 : Normal LRCLK polarity 1: Inverted LRCLK polarity
				In DSP Mode: 0 : DSP mode A 1: DSP mode B

By default, LRCLK and DIN1/2/3 are sampled on the rising edge of BCLK and should ideally change on the falling edge. Data sources that change LRCLK and DIN1/2/3 on the rising edge of BCLK can be supported by setting the BCP register bit. Setting BCP to 1 inverts the polarity of BCLK to the inverse of that shown in Figure 13, Figure 14, Figure 15, Figure 16, and Figure 17.

REGISTER ADDRESS	BIT	LABEL	DEFAULT	DESCRIPTION
0000011 Interface Control	3	BCP	0	BCLK Polarity (DSP Modes): 0: Normal BCLK polarity 1: Inverted BCLK polarity

The IWL[1:0] bits are used to control the input word length.

REGISTER ADDRESS	BIT	LABEL	DEFAULT	DESCRIPTION
0000011 Interface Control	5:4	IWL [1:0]	00	Input Word Length: 00 : 16 bit data 01: 20 bit data 10: 24 bit data 11: 32 bit data

**Note:** 32-bit right justified mode is not supported.

In all modes, the data is signed 2's complement. The digital filters always input 24-bit data. If the DAC is programmed to receive 16 or 20 bit data, the WM8522 pads the unused LSBs with zeros. If the DAC is programmed into 32 bit mode, the 8 LSBs are ignored.

**Note:** In 24 bit I<sup>2</sup>S mode, any width of 24 bits or less is supported provided that LRCLK is high for a minimum of 24 BCLKs and low for a minimum of 24 BCLKs.

A number of options are available to control how data from the Digital Audio Interface is applied to the DAC channels.

### DAC OUTPUT PHASE

The DAC phase control word determines whether the output of each DAC is non-inverted or inverted

REGISTER ADDRESS	BIT	LABEL	DEFAULT	DESCRIPTION		
0000011 DAC Phase	8:6	PHASE [2:0]	000	Bit	DAC	Phase
				0	DAC1L/R	1 = invert
				1	DAC2L/R	1 = invert
				2	DAC3L/R	1 = invert

### DIGITAL ZERO CROSS-DETECT

The digital volume control also incorporates a zero cross detect circuit which detects a transition through the zero point before updating the digital volume control with the new volume. This is enabled by control bit DZCEN.

REGISTER ADDRESS	BIT	LABEL	DEFAULT	DESCRIPTION
0001001 DAC Control	0	ZCD	0	DAC Digital Volume Zero Cross Enable: 0: Zero cross detect enabled 1: Zero cross detect disabled

### SOFTMUTE

The digital muting function used in Software and Hardware mode applies a softmute with the operating characteristics shown in Figure 19.

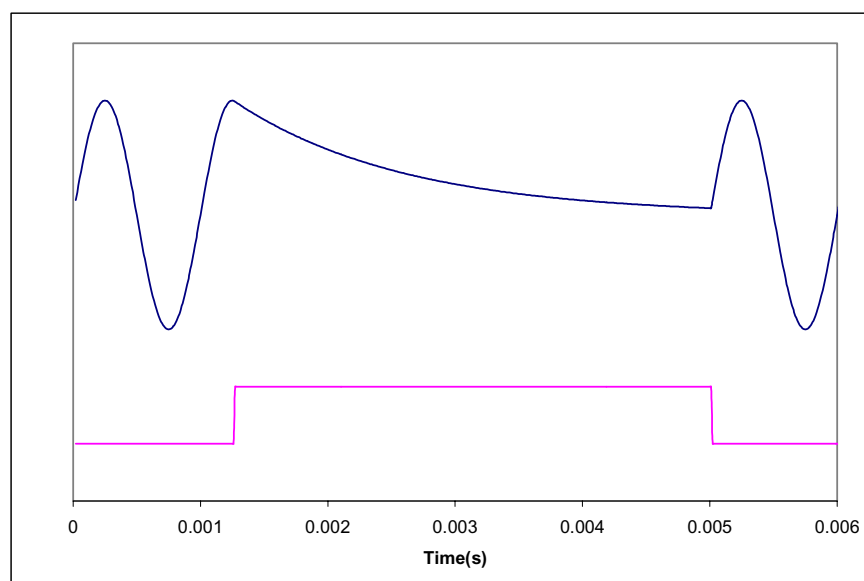

Figure 19 Soft Mute Operation

When the softmute is applied the output of the device will decay towards  $V_{MID}$  with a time constant of approximately 64 input samples. When the mute is released, either manually or automatically by the chip, the output will restart immediately from the current input sample.

### ANALOGUE MUTE

Analogue mute can only be used in software mode and will cause the output of the selected DAC to perform an analogue mute that clamps the output of the DAC to  $V_{MID}$ . This function is dependent in the IZD bit which is described in section INFINITE ZERO DETECT, later.

**SOFTWARE MODE**

The WM8522 can be muted in a number of different ways when in software mode (MODE pin pulled low). Refer to Figure 20 which shows a representation of the interaction between functions described below.

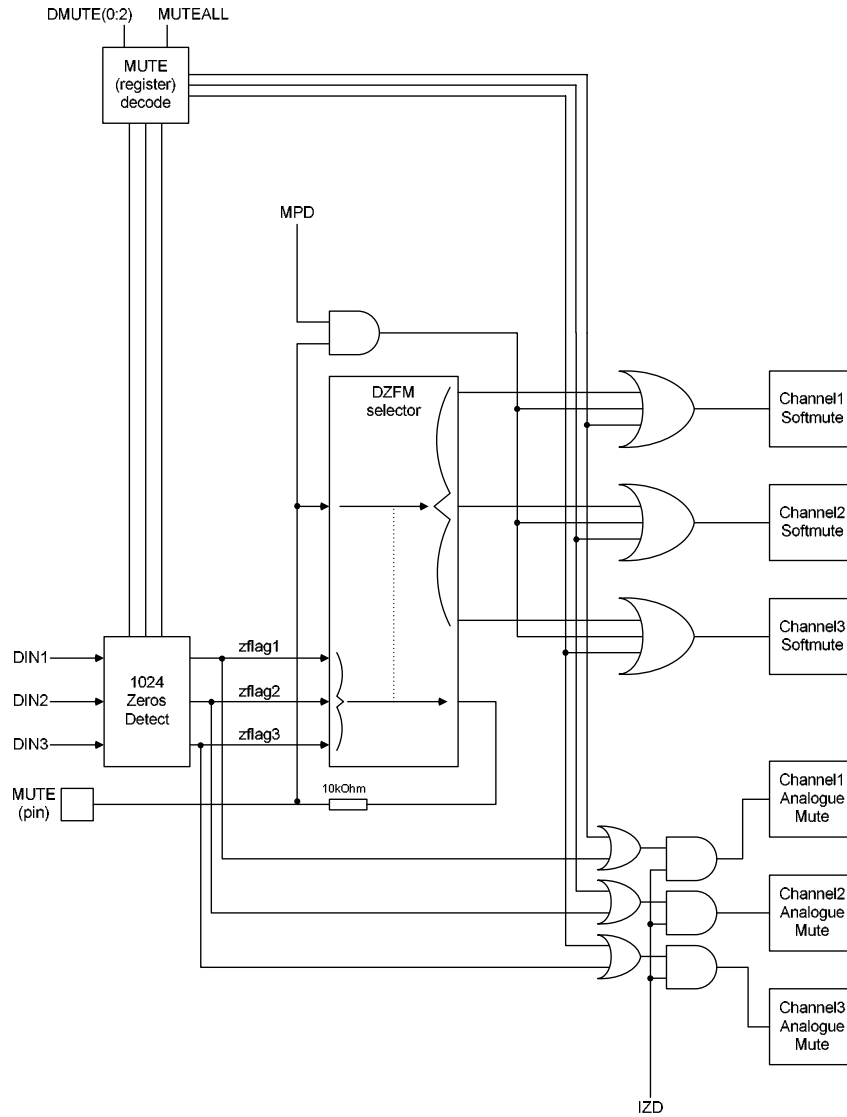

**Figure 20 Internal Mute Logic**

### DMUTE AND MUTEALL

Most simply, the WM8522 can be directly muted using the DMUTE register bit to control which channels are muted. The mute happens as soon as the serial write is performed.

REGISTER ADDRESS	BIT	LABEL	DEFAULT	DESCRIPTION
0001001 DAC Mute	5:3	DMUTE [2:0]	000	DAC Soft Mute Select

DMUTE [2:0]	DAC CHANNEL 1	DAC CHANNEL 2	DAC CHANNEL 3
000	Not MUTE	Not MUTE	Not MUTE
001	MUTE	Not MUTE	Not MUTE
010	Not MUTE	MUTE	Not MUTE
011	MUTE	MUTE	Not MUTE
100	Not MUTE	Not MUTE	MUTE
101	MUTE	Not MUTE	MUTE
110	Not MUTE	MUTE	MUTE
111	MUTE	MUTE	MUTE

**Table 10 DAC Mute Control**

An overall MUTE to all channels can be applied by using the MUTEALL register.

REGISTER ADDRESS	BIT	LABEL	DEFAULT	DESCRIPTION
0000010 DAC Mute	0	MUTEALL	0	Soft Mute Select: 0 : Normal operation 1: Soft mute all channels

### MUTE PIN AS INPUT

The WM8522 can be muted externally by driving the MUTE pin high. When the MUTE pin is driven low the device will never automute, although direct mutes can still be applied via the DMUTE or MUTEALL registers.

The DZFM bits are used to decode the operation of a MUTE pin (decides which channels will be affected by the logic level present on the MUTE pin). MPD (Mute Pin Decode) is used to enable the DZFM operation. If MPD is set, the selection made by the DZFM bits will be ignored and all channels will be muted when the pin is driven high.

Table 11 below describes which channels will be softmuted when the MUTE pin is driven high depending on the MPD and DZFM bits.

MPD	DZFM [1:0]	CHANNELS MUTED WHEN MUTE PIN HIGH
0	00	All Channels
0	01	CH1
0	10	CH2
0	11	CH3
1	00	All Channels
1	01	All Channels
1	10	All Channels
1	11	All Channels

**Table 11 Mute Pin Decode when Mute Pin as Input**



### AUTOMUTE

The WM8522 can automute by counting zero samples on the DIN1/2/3 inputs. When 1024 zero samples are counted on one channel, one of three internal zero flags (zflag1/2/3 shown in figure 2) is raised. Depending on the external hardware and settings of DZFM, MPD and IZD, different automute operations are possible.

### MUTE PIN AS OUTPUT

If the MUTE pin is connected to a high impedance (input to external mute circuitry for example) or left floating, zflag1/2/3 will be output on the Mute pin dependent on DZFM settings. This is described in Table 12 below. The output impedance of the MUTE pin is 10kΩ.

DZFM [1:0]	CONDITION UNDER WHICH MUTE PIN DRIVEN HIGH
00	Zflag1/2/3 all high
01	Zflag1 high
10	Zflag2 high
11	Zflag3 high

**Table 12 Effect of DZFM on Mute Pin Decode**

When the Mute pin is used as an output, its logic level remains connected to the DZFM selector inside the chip (see figure 1). So, when the WM8522 drives the Mute pin high, the output DACs will also softmute as described by Table 13.

MPD	DZFM [1:0]	CHANNELS MUTED WHEN MUTE PIN DRIVEN HIGH
0	00	All Channels
0	01	CH1
0	10	CH2
0	11	CH3
1	00	All Channels
1	01	All Channels
1	10	All Channels
1	11	All Channels

**Table 13 Mute Pin Decode when Mute Pin as Output**

### INFINITE ZERO DETECT

When it is set, the IZD register causes an analogue mute of the DAC channel output amplifier both when there are 1024 zeros on that channel's DIN pin or when it is manually muted by DMUTE or MUTEALL.

REGISTER ADDRESS	BIT	LABEL	DEFAULT	DESCRIPTION
0000010 DAC Channel Control	4	IZD	0	IZD Enable 0 : Disable infinite zero mute 1: Enable infinite zero mute

This operation is only available in software mode and can sometimes create a very small click at the output of the device.

**DE-EMPHASIS MODE**

Each stereo DAC channel has an individual de-emphasis control bit:

REGISTER ADDRESS	BIT	LABEL	DEFAULT	DESCRIPTION
0001001 DAC De-emphasis Control	[8:6]	DEEMPH [1:0]	000	De-emphasis Channel Selection Select:

DEEMPH [1:0]	DAC CHANNEL 1	DAC CHANNEL 2	DAC CHANNEL 3
000	Not DE-EMPHASIS	Not DE-EMPHASIS	Not DE-EMPHASIS
001	DE-EMPHASIS	Not DE-EMPHASIS	Not DE-EMPHASIS
010	Not DE-EMPHASIS	DE-EMPHASIS	Not DE-EMPHASIS
011	DE-EMPHASIS	DE-EMPHASIS	Not DE-EMPHASIS
100	Not DE-EMPHASIS	Not DE-EMPHASIS	DE-EMPHASIS
101	DE-EMPHASIS	Not DE-EMPHASIS	DE-EMPHASIS
110	Not DE-EMPHASIS	DE-EMPHASIS	DE-EMPHASIS
111	DE-EMPHASIS	DE-EMPHASIS	DE-EMPHASIS

**Table 14 De-emphasis Control**

Refer to Figure 30 for details of the De-Emphasis performance at different sample rates.

REGISTER ADDRESS	BIT	LABEL	DEFAULT	DESCRIPTION
0000010 DAC DEEMPH	1	DEEMPALL	0	DEEMPH Select: 0 : Normal operation 1: De-emphasis all channels

**POWERDOWN MODE AND DAC DISABLE**

Setting the PDWN register bit immediately powers down the DACs on the WM8522, overriding the DACD powerdown bits control bits. All trace of the previous input samples are removed, but all control register settings are preserved. When PDWN is cleared the digital filters will be reinitialised

REGISTER ADDRESS	BIT	LABEL	DEFAULT	DESCRIPTION
0000010 Powerdown Control	2	PDWN	0	Power Down all DAC's Select: 0: All DACs enabled 1: All DACs disabled

The DACs may also be powered down individually by setting the DACPD disable bit. Each Stereo DAC channel has a separate disable DACPD[2:0]. Setting DACPD for a channel will disable the DACs and select a low power mode.

REGISTER ADDRESS	BIT	LABEL	DEFAULT	DESCRIPTION
0001010 Powerdown Control	3:1	DACPD[2:0]	000	DAC Disable

DACPD [2:0]	DAC CHANNEL 1	DAC CHANNEL 2	DAC CHANNEL 3
000	Active	Active	Active
001	DISABLE	Active	Active
010	Active	DISABLE	Active
011	DISABLE	DISABLE	Active
100	Active	Active	DISABLE
101	DISABLE	Active	DISABLE
110	Active	DISABLE	DISABLE
111	DISABLE	DISABLE	DISABLE

Table 15 DAC Disable Control

### MASTER POWERDOWN

This control bit powers down the references for the whole chip. Therefore for complete powerdown, all DACs should be powered down first before setting this bit.

REGISTER ADDRESS	BIT	LABEL	DEFAULT	DESCRIPTION
0001010 Interface Control	4	PWRDNALL	0	Master Power Down Bit: 0: Not powered down 1: Powered down

### MASTER MODE SELECT

Control bit MS selects between audio interface Master and Slave Modes. In Master mode LRCLK and BCLK are outputs and are generated by the WM8522. In Slave mode LRCLK and BCLK are inputs to WM8522.

REGISTER ADDRESS	BIT	LABEL	DEFAULT	DESCRIPTION
0001010 Interface Control	5	MS	0	DAC Audio Interface Master/Slave Mode Select: 0: Slave mode 1: Master mode

### MASTER MODE LRCLK FREQUENCY SELECT

In Master mode the WM8522 generates LRCLK and BCLK. These clocks are derived from the master clock and the ratio of MCLK to LRCLK is set by RATE.

REGISTER ADDRESS	BIT	LABEL	DEFAULT	DESCRIPTION
0001010 Interface Control	8:6	RATE [2:0]	010	Master Mode MCLK:LRCLK Ratio Select: 000: 128fs 001: 192fs 010: 256fs 011: 384fs 100: 512fs 101: 768fs

**MUTE PIN DECODE**

The MUTE pin can either be used as an output or an input. When used as an input the MUTE pins action can be controlled by setting the DZFM bit to select the corresponding DAC for applying the MUTE to. As an output its meaning is selected by the DZFM control bits. By default selecting the MUTE pin to represent if DAC1 has received more than 1024 midrail samples will cause the MUTE pin to assert a softmute on DAC1. Disabling the decode block will cause any logical high on the MUTE pin to apply a softmute to all DAC's.

REGISTER ADDRESS	BIT	LABEL	DEFAULT	DESCRIPTION
0001100 MUTE Control	6	MPD	0	MUTE Pin Decode Disable: 0: MUTE pin decode enable 1: MUTE pin decode disable

**DAC DIGITAL VOLUME CONTROL**

The DAC volume may also be adjusted in the digital domain using independent digital attenuation control registers

REGISTER ADDRESS	BIT	LABEL	DEFAULT	DESCRIPTION
0000000 Digital Attenuation DACL1	7:0	LDA1[7:0]	11111111 (0dB)	Digital Attenuation data for Left channel DACL1 in 0.5dB steps. See Table 16
	8	UPDATE	Not latched	Controls simultaneous update of all Attenuation Latches 0: Store LDA1 in intermediate latch (no change to output) 1: Store LDA1 and update attenuation on all channels
0000001 Digital Attenuation DACR1	7:0	RDA1[6:0]	11111111 (0dB)	Digital Attenuation data for Right channel DACR1 in 0.5dB steps. See Table 16.
	8	UPDATE	Not latched	Controls simultaneous update of all Attenuation Latches 0: Store RDA1 in intermediate latch (no change to output) 1: Store RDA1 and update attenuation on all channels.
0000100 Digital Attenuation DACL2	7:0	LDA2[7:0]	11111111 (0dB)	Digital Attenuation data for Left channel DACL2 in 0.5dB steps. See Table 16
	8	UPDATE	Not latched	Controls simultaneous update of all Attenuation Latches 0: Store LDA2 in intermediate latch (no change to output) 1: Store LDA2 and update attenuation on all channels.
0000101 Digital Attenuation DACR2	7:0	RDA2[7:0]	11111111 (0dB)	Digital Attenuation data for Right channel DACR2 in 0.5dB steps. See Table 16
	8	UPDATE	Not latched	Controls simultaneous update of all Attenuation Latches 0: Store RDA2 in intermediate latch (no change to output) 1: Store RDA2 and update attenuation on all channels.
0000110 Digital Attenuation DACL3	7:0	LDA3[7:0]	11111111 (0dB)	Digital Attenuation data for Left channel DACL3 in 0.5dB steps. See Table 16
	8	UPDATE	Not latched	Controls simultaneous update of all Attenuation Latches 0: Store LDA3 in intermediate latch (no change to output) 1: Store LDA3 and update attenuation on all channels.
0000111 Digital Attenuation DACR3	7:0	RDA3[7:0]	11111111 (0dB)	Digital Attenuation data for Right channel DACR3 in 0.5dB steps. See Table 16
	8	UPDATE	Not latched	Controls simultaneous update of all Attenuation Latches 0: Store RDA3 in intermediate latch (no change to output) 1: Store RDA3 and update attenuation on all channels.
0001000 Master Digital Attenuation (all channels)	7:0	MASTDA [7:0]	11111111 (0dB)	Digital Attenuation data for all DAC channels in 0.5dB steps. See Table 16
	8	UPDATE	Not latched	Controls simultaneous update of all Attenuation Latches 0: Store gain in intermediate latch (no change to output) 1: Store gain and update attenuation on all channels.

**Note:**

**When MCLK is removed, digital volume settings are re-set to default (0dB). When MCLK is re-applied, the user must write the desired volume level to the volume control registers.**

L/RDAX[7:0]	ATTENUATION LEVEL
00(hex)	-∞ dB (mute)
01(hex)	-127dB
:	:
:	:
:	:
FE(hex)	-0.5dB
FF(hex)	0dB

Table 16 Digital Volume Control Attenuation Levels

### SOFTWARE REGISTER RESET

Writing to register 11111 will cause a register reset, resetting all register bits to their default values. The device will be held in this reset state until a subsequent register write to any address is completed.

## REGISTER MAP

The complete register map is shown below. The detailed description can be found in the relevant text of the device description. The WM8522 can be configured using the Control Interface. All unused bits should be set to '0'.

REGISTER	B15	B14	B13	B12	B11	B10	B9	B8	B7	B6	B5	B4	B3	B2	B1	B0	DEFAULT	
R0(00h)	0	0	0	0	0	0	0	UPDATE	LDA1[7:0]								01111111	
R1(01h)	0	0	0	0	0	0	1	UPDATE	RDA1[7:0]								01111111	
R2(02h)	0	0	0	0	0	1	0	PL[8:5]				IZD	ATC	PDWN	DEEMPALL	MUTEALL	10010000	
R3(03h)	0	0	0	0	0	1	1	PHASE[8:6]			IWL[5:4]		BCP	LRP	FMT[1:0]		00000000	
R4(04h)	0	0	0	0	1	0	0	UPDATE	LDA2[7:0]								01111111	
R5(05h)	0	0	0	0	1	0	1	UPDATE	RDA2[7:0]								01111111	
R6(06h)	0	0	0	0	1	1	0	UPDATE	LDA3[7:0]								01111111	
R7(07h)	0	0	0	0	1	1	1	UPDATE	RDA3[7:0]								01111111	
R8(08h)	0	0	0	1	0	0	0	UPDATE	MASTDA[7:0]								01111111	
R9(09h)	0	0	0	1	0	0	1	DEEMP[8:6]			DMUTE[5:3]			DZFM[2:1]		ZCD	00000000	
R10(0Ah)	0	0	0	1	0	1	0	RATE[8:6]			MS	PWRDNALL		DACPD[3:1]			0	01000000
R12(0Ch)	0	0	0	1	1	0	0	0	0	MPD	0	0	0	0	0	0	0	00000000
R31(1Fh)	0	0	1	1	1	1	1	RESET								00000000		

## REGISTER MAP DESCRIPTION

REGISTER ADDRESS	BIT	LABEL	DEFAULT	DESCRIPTION		
R0 (00h) Digital Attenuation DACL1	7:0	LDA1[7:0]	11111111 (0dB)	Digital Attenuation data for Left channel DACL1 in 0.5dB steps. See Table 16		
	8	UPDATE	Not latched	Controls simultaneous update of all Attenuation Latches 0: Store LDA1 in intermediate latch (no change to output) 1: Store LDA1 and update attenuation on all channels		
R1 (01h) Digital Attenuation DACR1	7:0	RDA1[6:0]	11111111 (0dB)	Digital Attenuation data for Right channel DACR1 in 0.5dB steps. See Table 16.		
	8	UPDATE	Not latched	Controls simultaneous update of all Attenuation Latches 0: Store RDA1 in intermediate latch (no change to output) 1: Store RDA1 and update attenuation on all channels.		
R2 (02h) DAC DEEMPH	0	MUTEALL	0	Soft Mute Select: 0 : Normal operation 1: Soft mute all channels		
	1	DEEMPALL	0	DEEMPH Select: 0 : Normal operation 1: De-emphasis all channels		
	2	PDWN	0	Power Down all DAC's Select: 0: All DACs enabled 1: All DACs disabled		
	3	ATC	0	Attenuator Control Mode: 0: Right channels use right attenuations 1: Right channels use left attenuations		
	4	IZD	0	IZD Enable 0 : Disable infinite zero mute 1: Enable infinite zero mute		
	8:5	PL[3:0]	1001	PL[3:0]	Left Output	Right Output
				0000	Mute	Mute
				0001	Left	Mute
				0010	Right	Mute
				0011	(L+R)/2	Mute
				0100	Mute	Left
				0101	Left	Left
				0110	Right	Left
				0111	(L+R)/2	Left
				1000	Mute	Right
				1001	Left	Right
				1010	Right	Right
1011	(L+R)/2	Right				
1100	Mute	(L+R)/2				
1101	Left	(L+R)/2				
1110	Right	(L+R)/2				
1111	(L+R)/2	(L+R)/2				
R3 (03h) DAC Phase	1:0	FMT[1:0]	00	Interface Format Select: 00 : Right justified mode 01: Left justified mode 10: I <sup>2</sup> S mode 11: DSP modes A or B		

REGISTER ADDRESS	BIT	LABEL	DEFAULT	DESCRIPTION		
	2	LRP	0	In left/right/I <sup>2</sup> S Modes: LRCLK Polarity (normal) 0 : Normal LRCLK polarity 1: Inverted LRCLK polarity		
				In DSP Mode: 0 : DSP mode A 1: DSP mode B		
	3	BCP	0	BCLK Polarity (DSP Modes): 0: Normal BCLK polarity 1: Inverted BCLK polarity		
	5:4	IWL[5:4]	00	Input Word Length: 00 : 16 bit data 01: 20 bit data 10: 24 bit data 11: 32 bit data		
	8:6	PHASE [8:6]	000	Bit	DAC	Phase
				0	DAC1L/R	1 = invert
				1	DAC2L/R	1 = invert
				2	DAC3L/R	1 = invert
R4 (04h) Digital Attenuation DACL2	7:0	LDA2[7:0]	11111111 (0dB)	Digital Attenuation data for Left channel DACL2 in 0.5dB steps. See Table 16		
	8	UPDATE	Not latched	Controls simultaneous update of all Attenuation Latches 0: Store LDA2 in intermediate latch (no change to output) 1: Store LDA2 and update attenuation on all channels.		
R5 (05h) Digital Attenuation DACR2	7:0	RDA2[7:0]	11111111 (0dB)	Digital Attenuation data for Right channel DACR2 in 0.5dB steps. See Table 16		
	8	UPDATE	Not latched	Controls simultaneous update of all Attenuation Latches 0: Store RDA2 in intermediate latch (no change to output) 1: Store RDA2 and update attenuation on all channels.		
R6 (06h) Digital Attenuation DACL3	7:0	LDA3[7:0]	11111111 (0dB)	Digital Attenuation data for Left channel DACL3 in 0.5dB steps. See Table 16		
	8	UPDATE	Not latched	Controls simultaneous update of all Attenuation Latches 0: Store LDA3 in intermediate latch (no change to output) 1: Store LDA3 and update attenuation on all channels.		
R7 (07h) Digital Attenuation DACR3	7:0	RDA3[7:0]	11111111 (0dB)	Digital Attenuation data for Right channel DACR3 in 0.5dB steps. See Table 16		
	8	UPDATE	Not latched	Controls simultaneous update of all Attenuation Latches 0: Store RDA3 in intermediate latch (no change to output) 1: Store RDA3 and update attenuation on all channels.		
R8 (08h) Master Digital Attenuation (all channels)	7:0	MASTDA [7:0]	11111111 (0dB)	Digital Attenuation data for all DAC channels in 0.5dB steps. See Table 16		
	8	UPDATE	Not latched	Controls simultaneous update of all Attenuation Latches 0: Store gain in intermediate latch (no change to output) 1: Store gain and update attenuation on all channels.		
R9 (09h) DAC Mute	0	ZCD	0	DAC Digital Volume Zero Cross Enable: 0: Zero cross detect enabled 1: Zero cross detect disabled		
	2:1	DZFM[1:0]	00	Zero flag/mute decode. See Table 11, Table 12 and Table 13 for details.		
	5:3	DMUTE [2:0]	000	DAC Soft Mute Select. See Table 10 for details.		



REGISTER ADDRESS	BIT	LABEL	DEFAULT	DESCRIPTION
	[8:6]	DEEMPH [1:0]	000	De-emphasis Channel Selection Select. See Table 14 for details.
R10 (0Ah) Interface Control	3:1	DACPD[2:0]	000	DAC Disable. See Table 15 for details
	4	PWRDNALL	0	Master Power Down Bit: 0: Not powered down 1: Powered down
	5	MS	0	DAC Audio Interface Master/Slave Mode Select: 0: Slave mode 1: Master mode
	8:6	RATE [2:0]	010	Master Mode MCLK:LRCLK Ratio Select: 000: 128fs 001: 192fs 010: 256fs 011: 384fs 100: 512fs 101: 768fs
R12 (0Ch) MUTE Control	6	MPD	0	MUTE Pin Decode Disable: 0: MUTE pin decode enable 1: MUTE pin decode disable
R31 (1Fh)	8:0	RESET	000000000	Writing to register 11111 will cause a register reset, resetting all register bits to their default values. The device will be held in this reset state until a subsequent register write to any address is completed

### DIGITAL FILTER CHARACTERISTICS

PARAMETER	TEST CONDITIONS	MIN	TYP	MAX	UNIT
DAC Filter					
Passband	$\pm 0.05$ dB			0.444fs	
	-3dB		0.487fs		
Passband ripple				$\pm 0.05$	dB
Stopband		0.555fs			
Stopband Attenuation	$f > 0.555fs$	-60			dB
Group Delay			21		fs

Table 17 Digital Filter Characteristics

### DAC FILTER RESPONSES

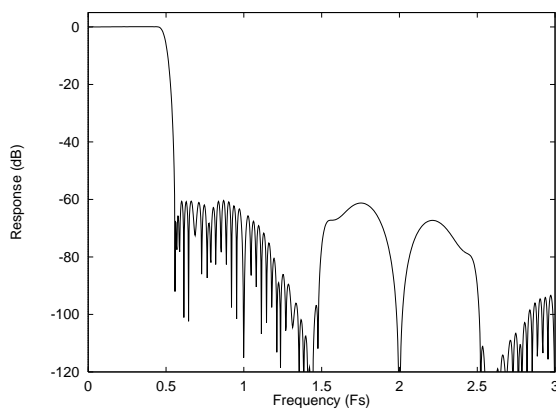

Figure 21 DAC Digital Filter Frequency Response – 44.1, 48 and 96kHz

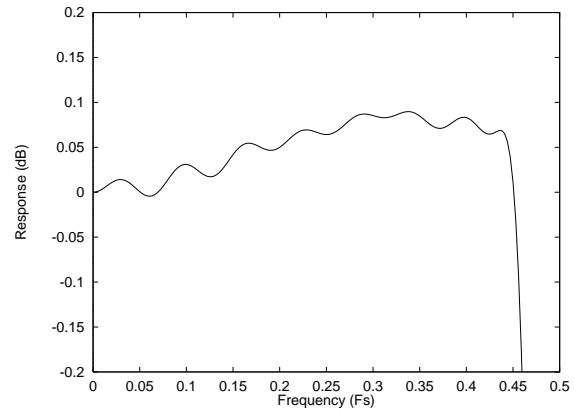

Figure 22 DAC Digital Filter Ripple – 44.1, 48 and 96kHz

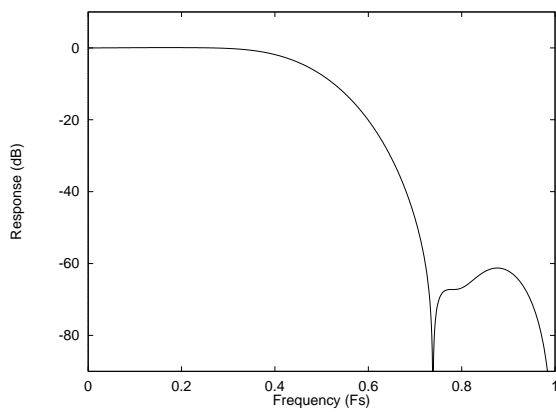

Figure 23 DAC Digital Filter Frequency Response – 192kHz

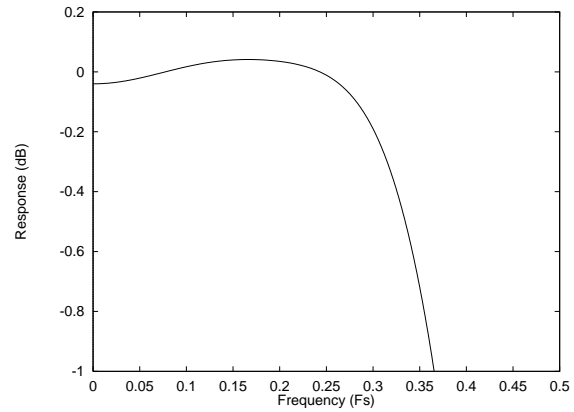

Figure 24 DAC Digital Filter Ripple – 192kHz

### DIGITAL DE-EMPHASIS CHARACTERISTICS

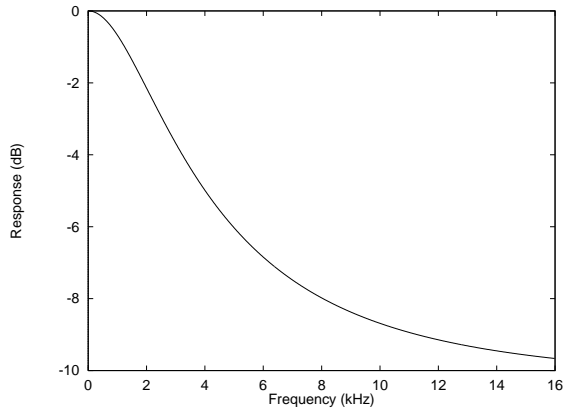

Figure 25 De-Emphasis Frequency Response (32kHz)

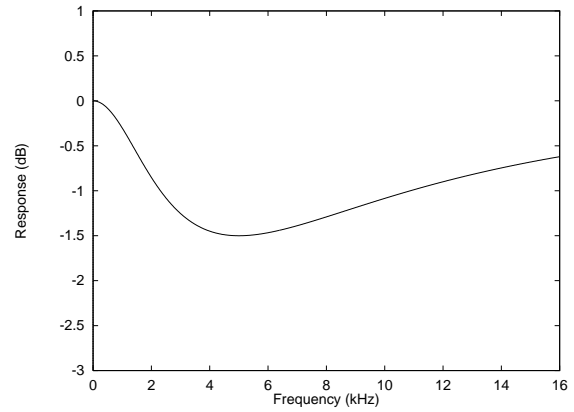

Figure 26 De-Emphasis Error (32kHz)

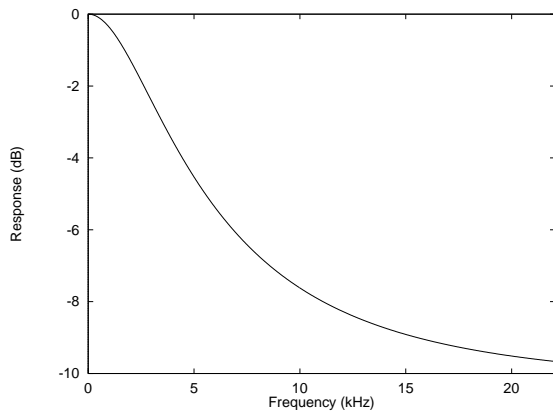

Figure 27 De-Emphasis Frequency Response (44.1kHz)

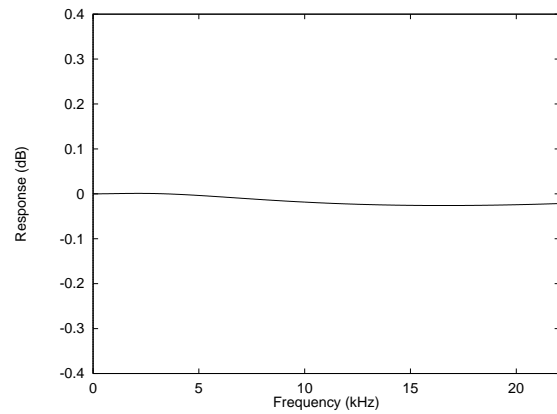

Figure 28 De-Emphasis Error (44.1kHz)

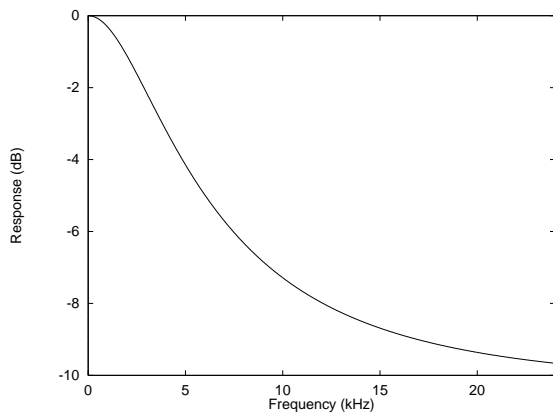

Figure 29 De-Emphasis Frequency Response (48kHz)

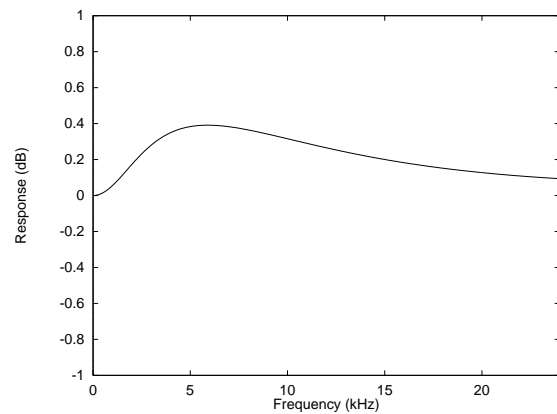
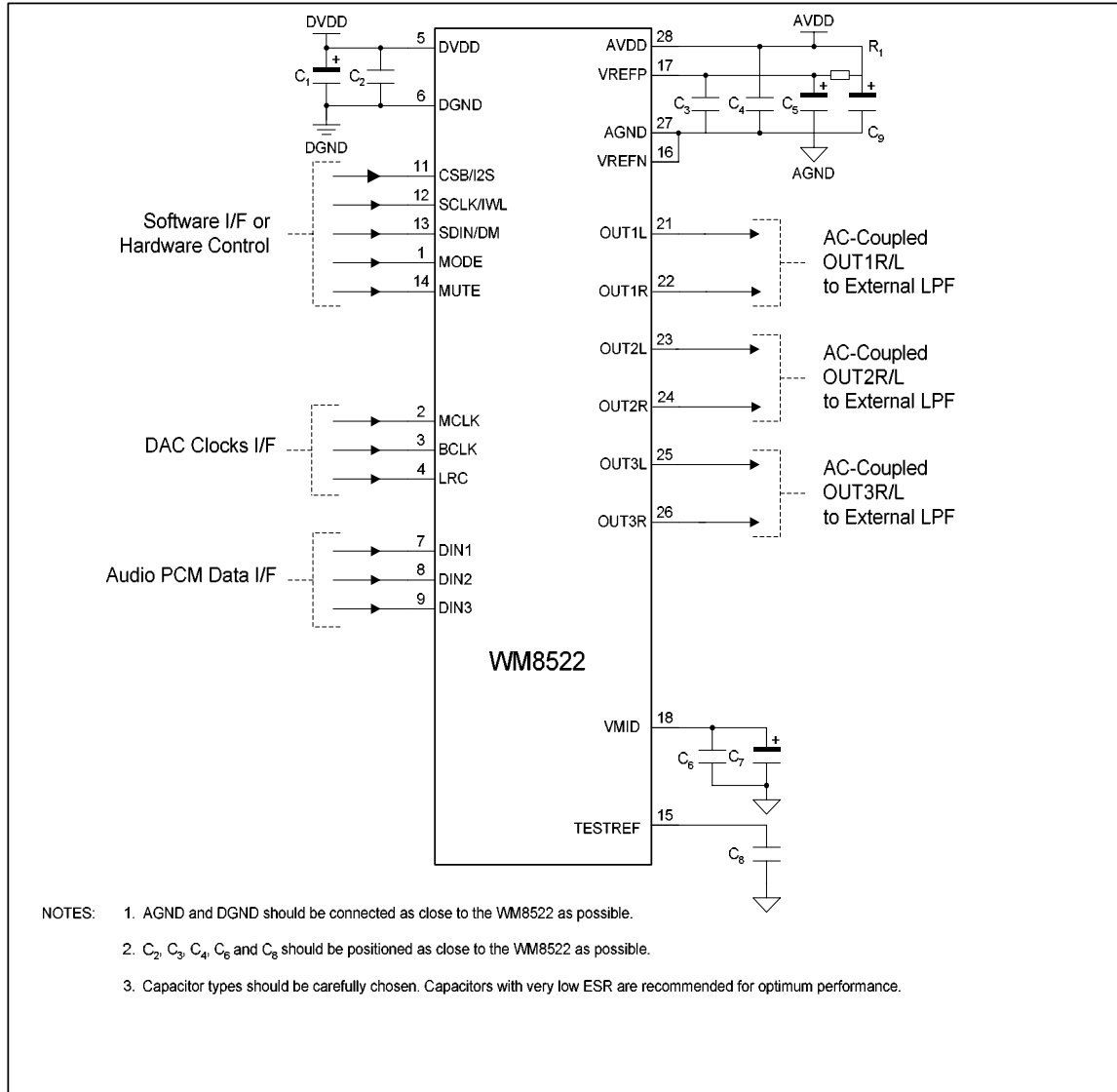

Figure 30 De-Emphasis Error (48kHz)

APPLICATIONS INFORMATION

RECOMMENDED EXTERNAL COMPONENTS



RECOMMENDED EXTERNAL COMPONENTS VALUES

COMPONENT REFERENCE	SUGGESTED VALUE	DESCRIPTION
C1 and C5	10µF	De-coupling for DVDD and AVDD.
C2 to C4	0.1µF	De-coupling for DVDD and AVDD.
C6	0.1µF	Reference de-coupling capacitors for VMID and TESTREF pin.
C7	10µF	
C8	0.1µF	De-coupling for TESTREF.
C9	100µF	Filtering for VREFP. Omit if AVDD low noise.
R1	33Ω	Filtering for VREFP. Use 0Ω if AVDD low noise.

Table 18 External Components Description

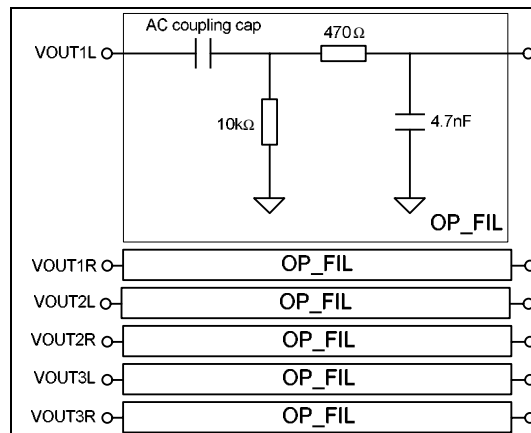
**SUGGESTED ANALOGUE LOW PASS POST DAC FILTERS****Figure 31 Recommended 1st Order Low Pass Filter**

**Note:** Capacitors should be COG dielectric.

An external single pole RC filter is recommended for each channel (see Figure 31) if the device is driving a wideband amplifier. However the WM8522 does contain an internal low pass filter which should be adequate in most applications.

PACKAGE DIMENSIONS

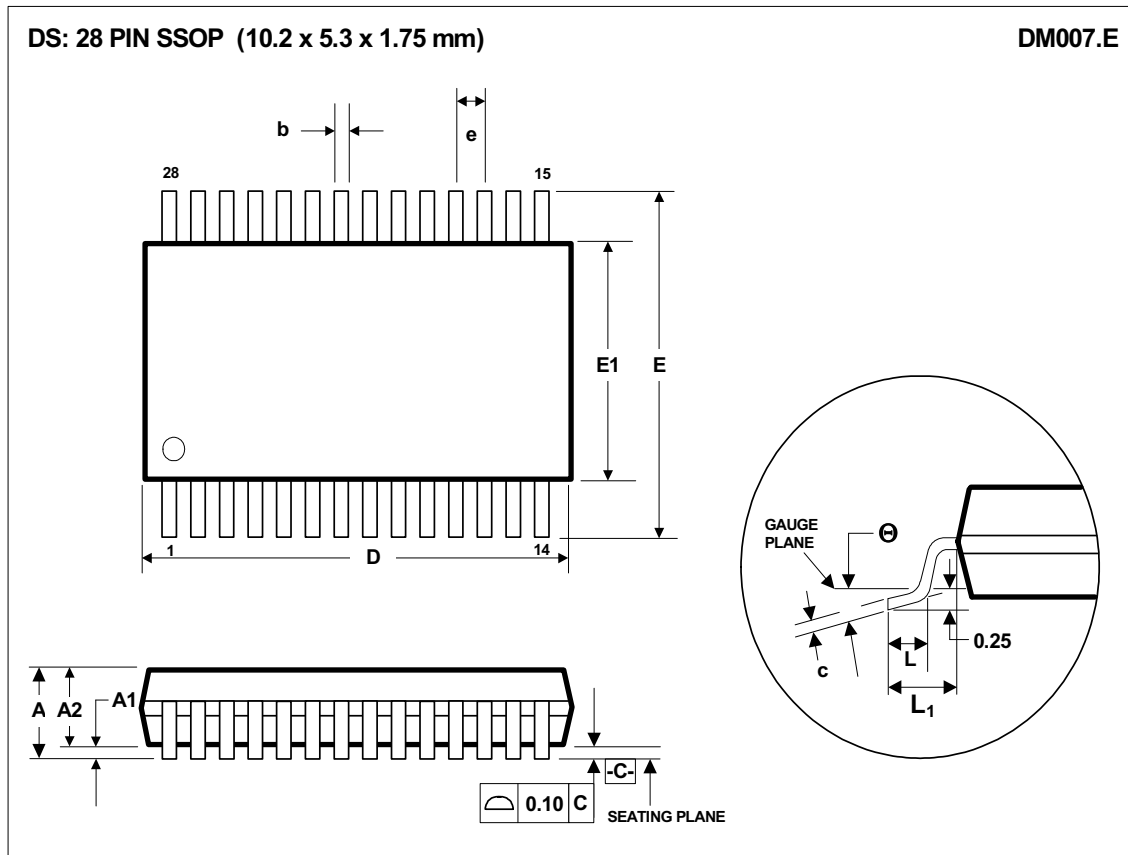

Symbols	Dimensions (mm)		
	MIN	NOM	MAX
<b>A</b>	----	----	2.0
<b>A<sub>1</sub></b>	0.05	----	0.25
<b>A<sub>2</sub></b>	1.65	1.75	1.85
<b>b</b>	0.22	0.30	0.38
<b>c</b>	0.09	----	0.25
<b>D</b>	9.90	10.20	10.50
<b>e</b>	0.65 BSC		
<b>E</b>	7.40	7.80	8.20
<b>E<sub>1</sub></b>	5.00	5.30	5.60
<b>L</b>	0.55	0.75	0.95
<b>L<sub>1</sub></b>	1.25 REF		
<b>θ</b>	0°	4°	8°
<b>REF:</b>	JEDEC.95, MO-150		

- NOTES:  
 A. ALL LINEAR DIMENSIONS ARE IN MILLIMETERS.  
 B. THIS DRAWING IS SUBJECT TO CHANGE WITHOUT NOTICE.  
 C. BODY DIMENSIONS DO NOT INCLUDE MOLD FLASH OR PROTRUSION, NOT TO EXCEED 0.20MM.  
 D. MEETS JEDEC.95 MO-150, VARIATION = AH. REFER TO THIS SPECIFICATION FOR FURTHER DETAILS.

## IMPORTANT NOTICE

Wolfson Microelectronics plc (WM) reserve the right to make changes to their products or to discontinue any product or service without notice, and advise customers to obtain the latest version of relevant information to verify, before placing orders, that information being relied on is current. All products are sold subject to the WM terms and conditions of sale supplied at the time of order acknowledgement, including those pertaining to warranty, patent infringement, and limitation of liability.

WM warrants performance of its products to the specifications applicable at the time of sale in accordance with WM's standard warranty. Testing and other quality control techniques are utilised to the extent WM deems necessary to support this warranty. Specific testing of all parameters of each device is not necessarily performed, except those mandated by government requirements.

In order to minimise risks associated with customer applications, adequate design and operating safeguards must be used by the customer to minimise inherent or procedural hazards. Wolfson products are not authorised for use as critical components in life support devices or systems without the express written approval of an officer of the company. Life support devices or systems are devices or systems that are intended for surgical implant into the body, or support or sustain life, and whose failure to perform when properly used in accordance with instructions for use provided, can be reasonably expected to result in a significant injury to the user. A critical component is any component of a life support device or system whose failure to perform can be reasonably expected to cause the failure of the life support device or system, or to affect its safety or effectiveness.

WM assumes no liability for applications assistance or customer product design. WM does not warrant or represent that any license, either express or implied, is granted under any patent right, copyright, mask work right, or other intellectual property right of WM covering or relating to any combination, machine, or process in which such products or services might be or are used. WM's publication of information regarding any third party's products or services does not constitute WM's approval, license, warranty or endorsement thereof.

Reproduction of information from the WM web site or datasheets is permissible only if reproduction is without alteration and is accompanied by all associated warranties, conditions, limitations and notices. Representation or reproduction of this information with alteration voids all warranties provided for an associated WM product or service, is an unfair and deceptive business practice, and WM is not responsible nor liable for any such use.

Resale of WM's products or services with statements different from or beyond the parameters stated by WM for that product or service voids all express and any implied warranties for the associated WM product or service, is an unfair and deceptive business practice, and WM is not responsible nor liable for any such use.

### ADDRESS:

Wolfson Microelectronics plc  
Westfield House  
26 Westfield Road  
Edinburgh  
EH11 2QB  
United Kingdom

Tel :: +44 (0)131 272 7000

Fax :: +44 (0)131 272 7001

Email :: [sales@wolfsonmicro.com](mailto:sales@wolfsonmicro.com)