

NLAS3699

Dual DPDT Ultra-Low R_{ON} Switch

The NLAS3699 is a dual independent ultra-low R_{ON} DPDT analog switch. This device is designed for low operating voltage, high current switching of speaker output for cell phone applications. It can switch a balanced stereo output. The NLAS3699 can handle a balanced microphone/speaker/ring-tone generator in a monophone mode. The device contains a break-make feature.

Features

- Single Supply Operation
1.65 to 4.7 V V_{CC}
Function Directly from LiON Battery
- Maximum Breakdown Voltage: 5.0 V
- Tiny 3 x 3 mm QFN Pb-Free Package
Meet JEDEC MO-220 Specifications
- Low Static Power

Typical Applications

- Cell Phone Speaker/Microphone Switching
- Ringtone-Chip/Amplifier Switching
- Four Unbalanced (Single-Ended) Switches
- Stereo Balanced (Push-Pull) Switching

Important Information

- ESD Protection:
HBM (Human Body Model) > 4000 V
MM (Machine Model) > 400 V
- Continuous Current Rating Through each Switch ± 300 mA
- Conforms to: JEDEC MO-220, Issue H, Variation VEED-6
- Pin for Pin Compatible with STG3699



ON Semiconductor®

<http://onsemi.com>

MARKING DIAGRAMS

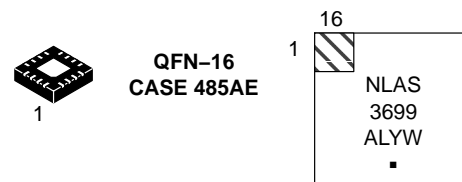

XXXX = Specific Device Code
A = Assembly Location
L = Wafer Lot
Y = Year
W = Work Week
▪ = Pb-Free Package

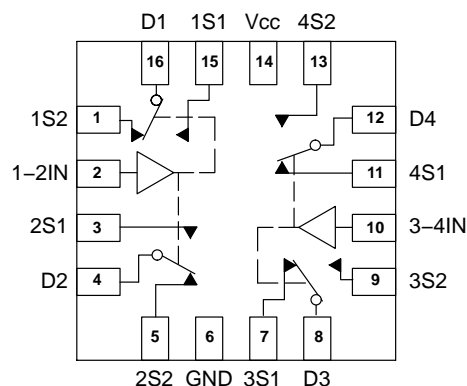

ORDERING INFORMATION

See detailed ordering and shipping information in the package dimensions section on page 9 of this data sheet.

NLAS3699

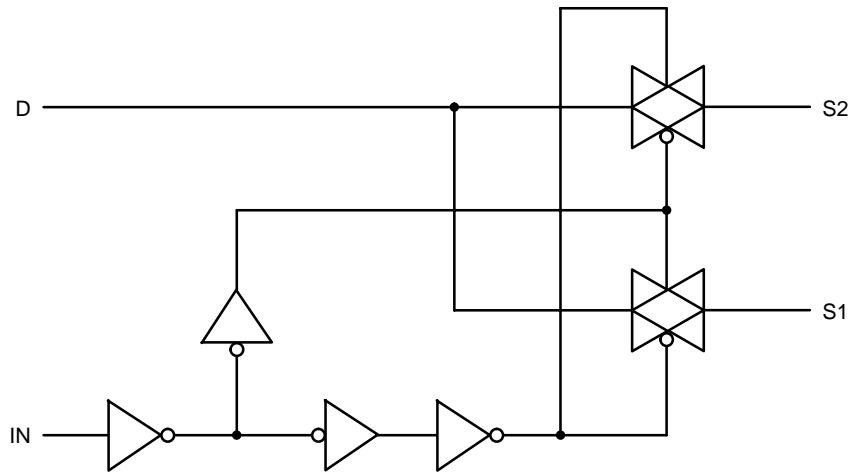

Figure 1. Input Equivalent Circuit

PIN DESCRIPTION

QFN PIN #	Symbol	Name and Function
1, 3, 5, 7, 9, 11, 13, 15	1S1 to 4S1, 1S2 to 4S2	Independent Channels
2, 10	1-2IN, 3-4IN	Controls
4, 8, 12, 16	D1 to D4	Common Channels
6	GND	Ground (V)
14	V _{CC}	Positive Supply Voltage

TRUTH TABLE

IN	S1	S2
H	ON	OFF(*)
L	OFF(*)	ON

*High impedance.

NLAS3699

MAXIMUM RATINGS

Symbol	Parameter	Value	Unit
V_{CC}	Positive DC Supply Voltage	-0.5 to +5.0	V
V_{IS}	Analog Input Voltage (V_{NO} , V_{NC} , or V_{COM})	$-0.5 \leq V_{IS} \leq V_{CC} + 0.5$	V
V_{IN}	Digital Select Input Voltage	$-0.5 \leq V_I \leq +5.0$	V
I_{anI1}	Continuous DC Current from COM to NC/NO	± 300	mA
$I_{anI-pk 1}$	Peak Current from COM to NC/NO, 10 duty cycle (Note 1)	± 500	mA
I_{clmp}	Continuous DC Current into COM/NO/NC with respect to V_{CC} or GND	± 100	mA

Maximum ratings are those values beyond which device damage can occur. Maximum ratings applied to the device are individual stress limit values (not normal operating conditions) and are not valid simultaneously. If these limits are exceeded, device functional operation is not implied, damage may occur and reliability may be affected.

1. Defined as 10% ON, 90% off duty cycle.

RECOMMENDED OPERATING CONDITIONS

Symbol	Parameter	Min	Max	Unit
V_{CC}	DC Supply Voltage	1.65	4.7	V
V_{IN}	Digital Select Input Voltage	GND	V_{CC}	V
V_{IS}	Analog Input Voltage (NC, NO, COM)	GND	V_{CC}	V
T_A	Operating Temperature Range	-55	+125	°C
t_r, t_f	Input Rise or Fall Time, SELECT		20 10	ns/V
			$V_{CC} = 1.6\text{ V} - 2.7\text{ V}$ $V_{CC} = 3.0\text{ V} - 4.7\text{ V}$	

NLAS3699

DC CHARACTERISTICS – Digital Section (Voltages Referenced to GND)

Symbol	Parameter	Condition	V _{CC} ± 10%	Guaranteed Limit			Unit
				–55°C to 25°C	< 85°C	< 125°C	
V _{IH}	Minimum High-Level Input Voltage, Select Inputs		1.8	1.2	1.2	1.2	V
			2.5	1.7	1.7	1.7	
			4.7	2.8	2.8	2.8	
V _{IL}	Maximum Low-Level Input Voltage, Select Inputs		1.8	0.4	0.4	0.4	V
			2.5	0.5	0.5	0.5	
			4.7	1.0	1.0	1.0	
I _{IN}	Maximum Input Leakage Current, Select Inputs	V _{IN} = 5.0 V or GND	4.7	± 0.1	± 1.0	± 1.0	µA
I _{OFF}	Power Off Leakage Current	V _{IN} = 5.0 V or GND	0	± 0.5	± 2.0	± 2.0	µA
I _{CC}	Maximum Quiescent Supply Current (Note 2)	Select and V _{IS} = V _{CC} or GND	1.65 to 4.7	± 1.0	± 2.0	± 2.5	µA

DC ELECTRICAL CHARACTERISTICS – Analog Section

Symbol	Parameter	Condition	V _{CC} ± 10%	Guaranteed Maximum Limit						Unit
				–55°C to 25°C		< 85°C		< 125°C		
				Min	Max	Min	Max	Min	Max	
R _{ON}	NC/NO On-Resistance (Note 2)	V _{IN} ≤ V _{IL} or V _{IN} ≥ V _{IH} V _{IS} = GND to V _{CC} I _{IN} ≤ 100 mA	2.5		0.6		0.6		0.7	Ω
			3.0		0.5		0.5		0.6	
			4.7		0.5		0.5		0.5	
R _{FLAT}	NC/NO On-Resistance Flatness (Notes 2, 4)	I _{COM} = 100 mA V _{IS} = 0 to V _{CC}	2.5		0.15		0.15		0.15	Ω
			3.0		0.15		0.15		0.15	
			4.7		0.15		0.15		0.15	
ΔR _{ON}	On-Resistance Match Between Channels (Notes 2 and 3)	V _{IS} = 1.3 V; I _{COM} = 100 mA V _{IS} = 1.5 V; I _{COM} = 100 mA V _{IS} = 2.8 V; I _{COM} = 100 mA	2.5		0.06		0.06		0.06	Ω
			3.0		0.05		0.05		0.05	
			4.7		0.05		0.05		0.05	
I _{NC(OFF)} I _{NO(OFF)}	NC or NO Off Leakage Current (Note 2)	V _{IN} = V _{IL} or V _{IH} V _{NO} or V _{NC} = 0.8 V V _{COM} = 3.7 V	4.7	–5.0	5.0	–10	10	–100	100	nA
I _{COM(ON)}	COM ON Leakage Current (Note 2)	V _{IN} = V _{IL} or V _{IH} V _{NO} 0.8 V or 3.7 V with V _{NC} floating or V _{NC} 0.8 V or 3.7 V with V _{NO} floating V _{COM} = 0.8 V or 3.7 V	4.7	–10	10	–100	100	–1000	1000	nA

2. Guaranteed by design. Resistance measurements do not include test circuit or package resistance.

3. ΔR_{ON} = R_{ON(MAX)} – R_{ON(MIN)} between NC1 and NC2 or between NO1 and NO2.

4. Flatness is defined as the difference between the maximum and minimum value of on-resistance as measured over the specified analog signal ranges.

NLAS3699

AC ELECTRICAL CHARACTERISTICS (Input $t_r = t_f = 3.0$ ns)

Symbol	Parameter	Test Conditions	V_{CC} (V)	V_{IS} (V)	Guaranteed Maximum Limit						Unit	
					-55°C to 25°C			< 85°C		< 125°C		
					Min	Typ*	Max	Min	Max	Min		Max
t_{ON}	Turn-On Time	$R_L = 50 \Omega$, $C_L = 35$ pF (Figures 3 and 4)	2.3 – 4.7	1.5			50		60		60	ns
t_{OFF}	Turn-Off Time	$R_L = 50 \Omega$, $C_L = 35$ pF (Figures 3 and 4)	2.3 – 4.7	1.5			30		40		40	ns
t_{BBM}	Minimum Break-Before-Make Time	$V_{IS} = 3.0$ $R_L = 300 \Omega$, $C_L = 35$ pF (Figure 2)	3.0	1.5	2	15						ns

		Typical @ 25, $V_{CC} = 5.0$ V		
C_{IN}	Control Pin Input Capacitance	2.5		pF
C_{SN}	SN Port Capacitance	72		pF
C_D	D Port Capacitance When Switch is Enabled	230		pF

*Typical Characteristics are at 25°C.

ADDITIONAL APPLICATION CHARACTERISTICS (Voltages Referenced to GND Unless Noted)

Symbol	Parameter	Condition	V_{CC} (V)	25°C	Unit
				Typical	
BW	Maximum On-Channel -3dB Bandwidth or Minimum Frequency Response (Figure 12)	V_{IN} centered between V_{CC} and GND (Figure 5)	1.65 – 4.7	20	MHz
V_{ONL}	Maximum Feed-through On Loss	$V_{IN} = 0$ dBm @ 100 kHz to 50 MHz V_{IN} centered between V_{CC} and GND (Figure 5)	1.65 – 4.7	-0.06	dB
V_{ISO}	Off-Channel Isolation (Figure 13)	$f = 100$ kHz; $V_{IS} = 1$ V RMS; $C_L = 5$ nF V_{IN} centered between V_{CC} and GND (Figure 5)	1.65 – 4.7	-62	dB
Q	Charge Injection Select Input to Common I/O (Figure 8)	$V_{IN} = V_{CC}$ to GND, $R_{IS} = 0 \Omega$, $C_L = 1$ nF $Q = C_L - \Delta V_{OUT}$ (Figure 6)	1.65 – 4.7	50	pC
THD	Total Harmonic Distortion THD + Noise (Figure 7)	$F_{IS} = 20$ Hz to 20 kHz, $R_L = R_{gen} = 600 \Omega$, $C_L = 50$ pF $V_{IS} = 2$ V RMS	4.3	0.01	%
VCT	Channel-to-Channel Crosstalk	$f = 100$ kHz; $V_{IS} = 1$ V RMS, $C_L = 5$ pF, $R_L = 50 \Omega$ V_{IN} centered between V_{CC} and GND (Figure 5)	1.65 – 4.7	-62	dB

5. Off-Channel Isolation = $20 \log_{10}(V_{com}/V_{no})$, V_{com} = output, V_{no} = input to off switch.

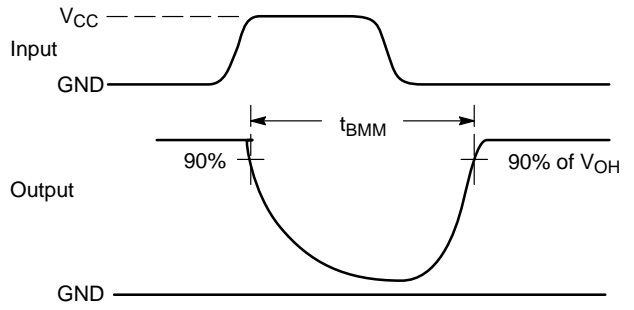
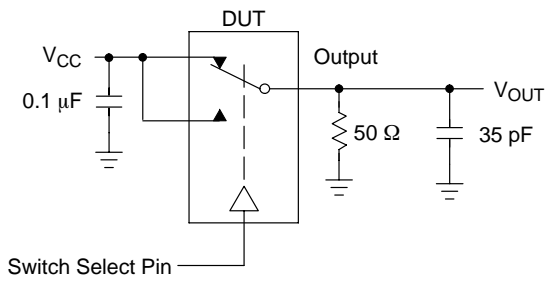

Figure 2. t_{BMM} (Time Break-Before-Make)

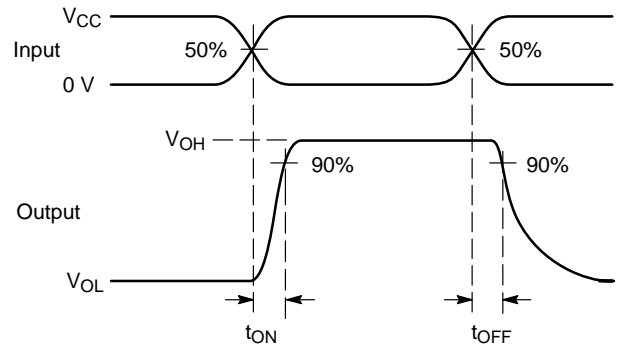
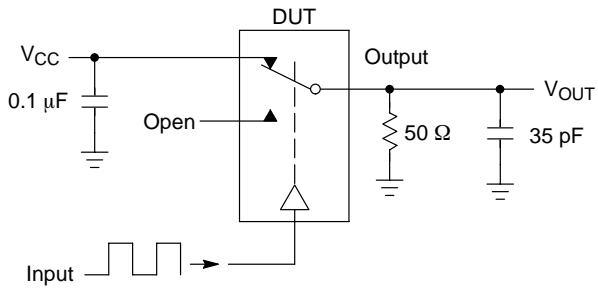

Figure 3. t_{ON}/t_{OFF}

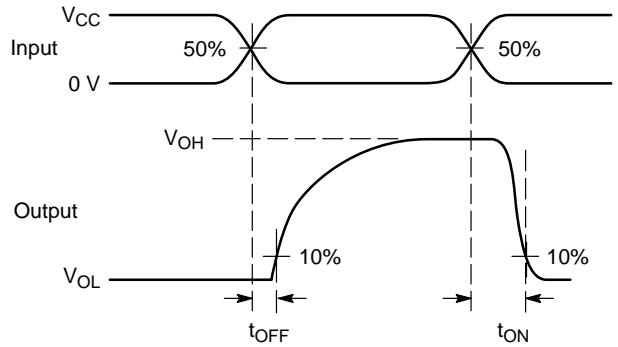
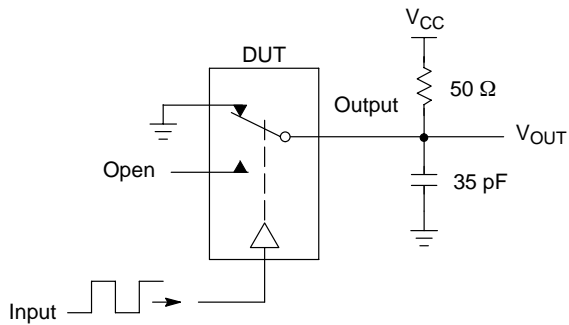
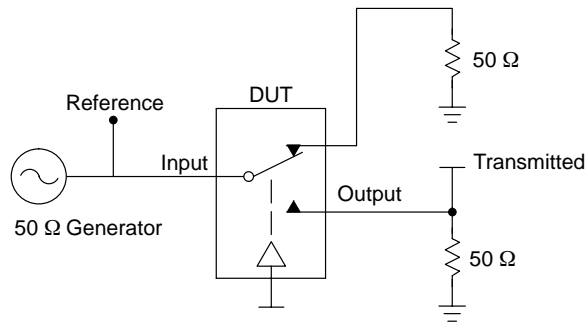

Figure 4. t_{ON}/t_{OFF}



Channel switch control/s test socket is normalized. Off isolation is measured across an off channel. On loss is the bandwidth of an On switch. V_{ISO} , Bandwidth and V_{ONL} are independent of the input signal direction.

$$V_{ISO} = \text{Off Channel Isolation} = 20 \text{ Log} \left(\frac{V_{OUT}}{V_{IN}} \right) \text{ for } V_{IN} \text{ at } 100 \text{ kHz}$$

$$V_{ONL} = \text{On Channel Loss} = 20 \text{ Log} \left(\frac{V_{OUT}}{V_{IN}} \right) \text{ for } V_{IN} \text{ at } 100 \text{ kHz to } 50 \text{ MHz}$$

Bandwidth (BW) = the frequency 3 dB below V_{ONL}

V_{CT} = Use V_{ISO} setup and test to all other switch analog input/outputs terminated with 50 Ω

Figure 5. Off Channel Isolation/On Channel Loss (BW)/Crosstalk (On Channel to Off Channel)/ V_{ONL}

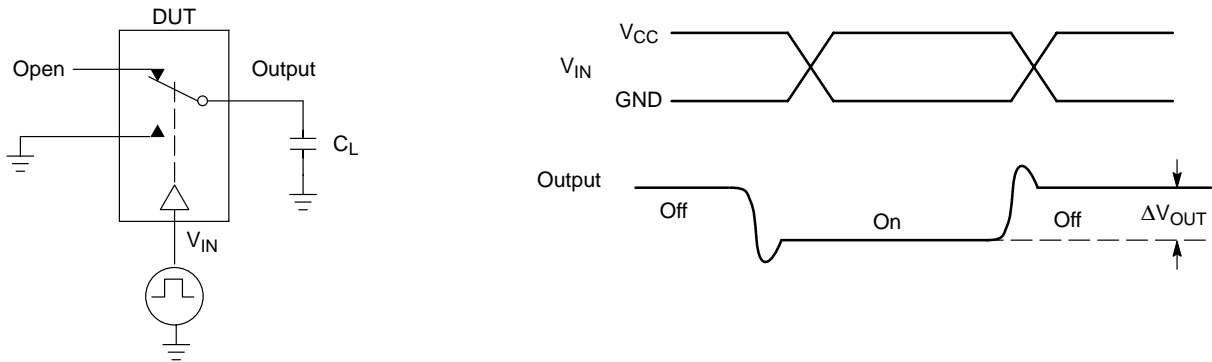

Figure 6. Charge Injection: (Q)

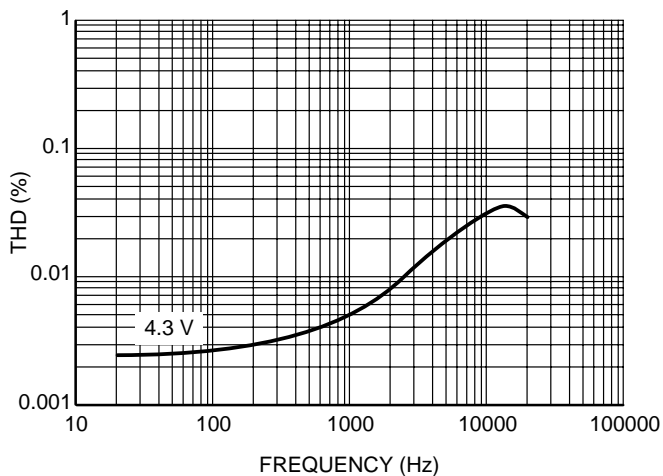

Figure 7. Total Harmonic Distortion Plus Noise Versus Frequency

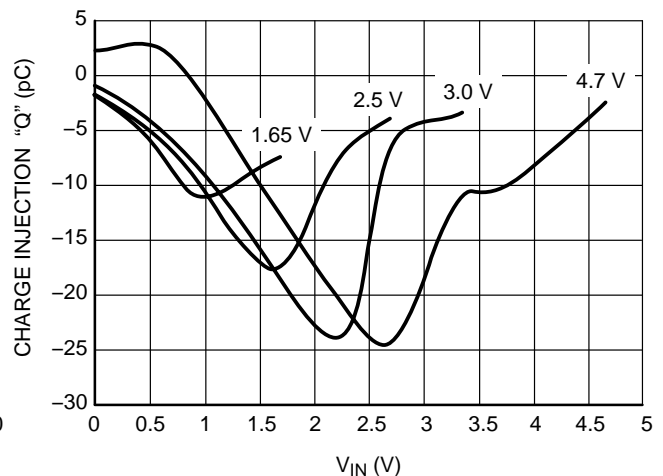

Figure 8. Charge Injection versus V_{is}

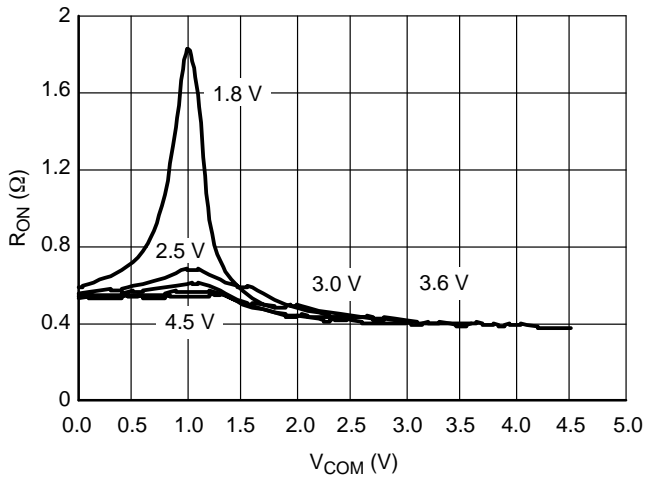

Figure 9. On-Resistance vs. COM Voltage

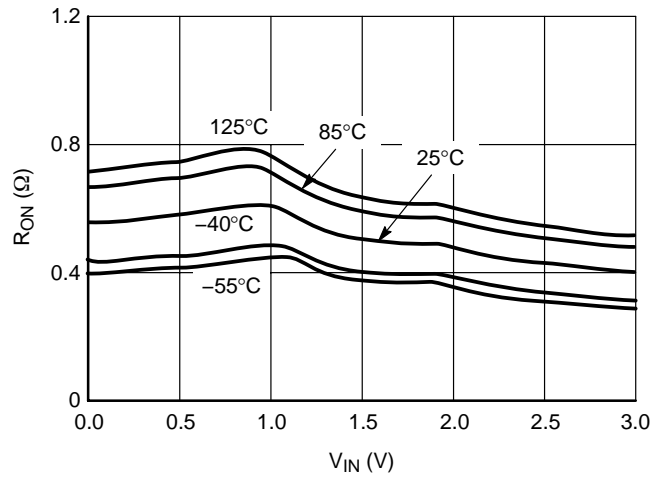

Figure 10. R_{ON} vs. V_{IN} vs. Temperature @ $V_{CC} = 3.0$ V

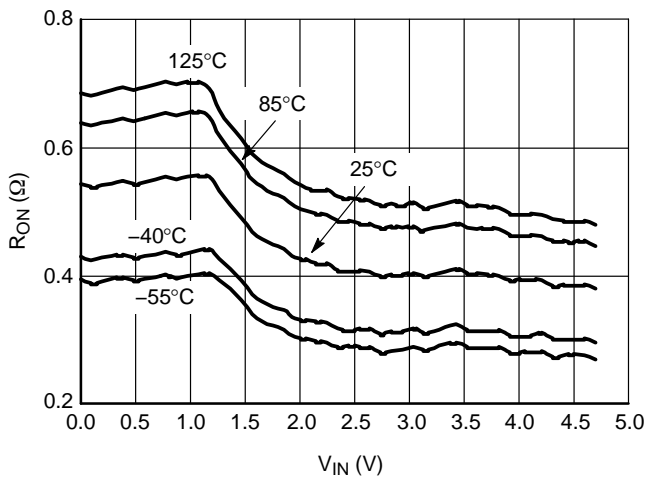

Figure 11. R_{ON} vs. V_{IN} vs. Temperature @ $V_{CC} = 4.7$ V

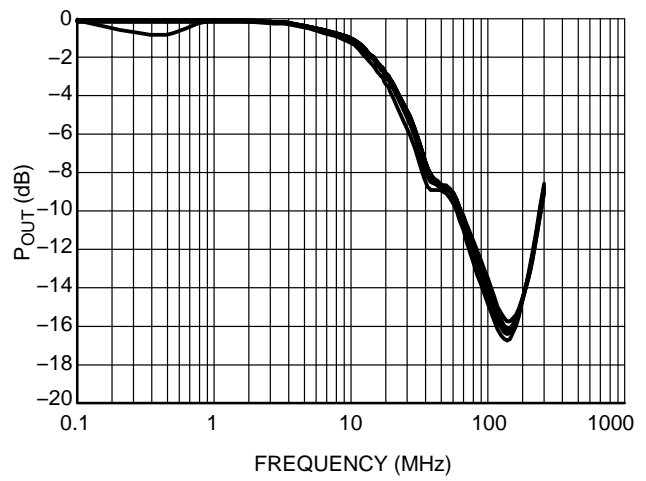

Figure 12. Bandwidth vs. Frequency @ $V_{CC} = 1.65$ V to 4.7 V

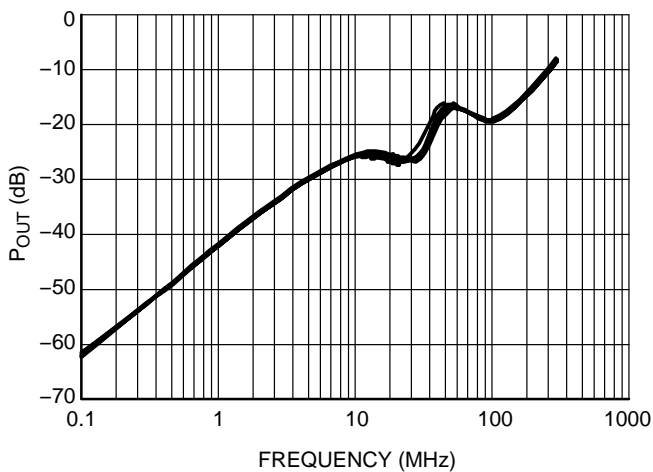

Figure 13. Off-Isolation vs. Frequency @ $V_{CC} = 1.65$ V to 4.7 V

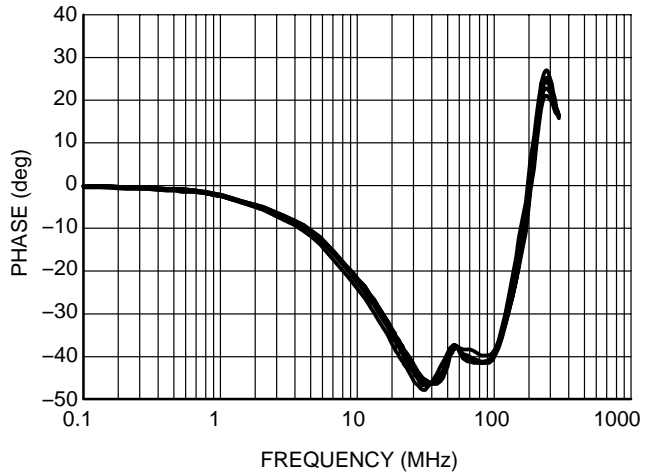

Figure 14. Phase Angle vs. Frequency @ $V_{CC} = 1.65$ V to 4.7 V

NLAS3699

DEVICE ORDERING INFORMATION

Device Order Number	Device Nomenclature					Package Type	Tape & Reel Size†
	Circuit Indicator	Technology	Device Function	Package Suffix	Tape & Reel Suffix		
NLAS3699MN1R2G	NL	AS	3699	MN1	R2	QFN (Pb-Free)	2500 Unit / Reel

†For information on tape and reel specifications, including part orientation and tape sizes, please refer to our Tape and Reel Packaging Specifications Brochure, BRD8011/D.

NLAS3699

PACKAGE DIMENSIONS

QFN-16 (3 x 3 x 0.85 mm)
CASE 485AE-01
ISSUE O

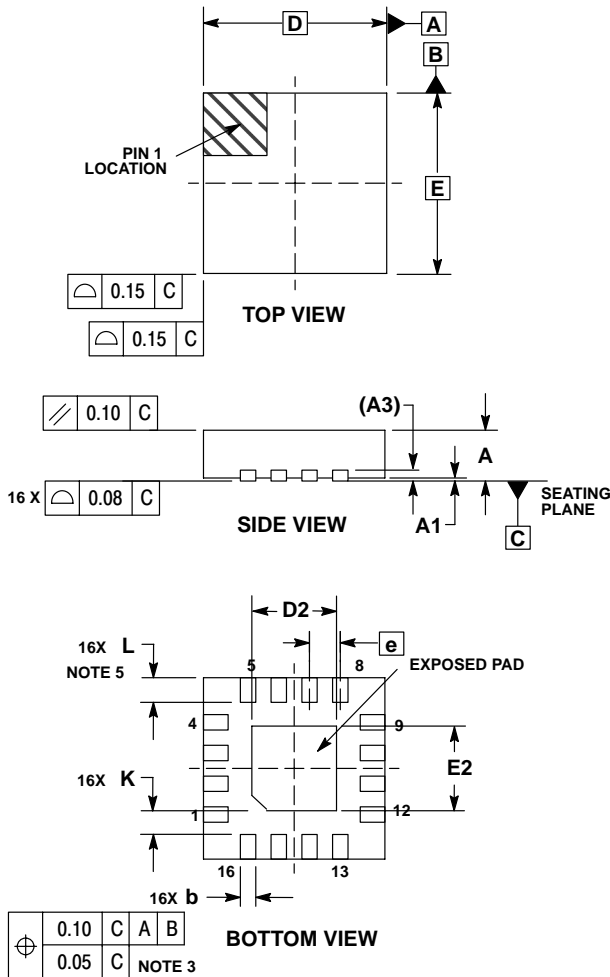

NOTES:

1. DIMENSIONING AND TOLERANCING PER ASME Y14.5M, 1994.
2. CONTROLLING DIMENSION: MILLIMETERS.
3. DIMENSION b APPLIES TO PLATED TERMINAL AND IS MEASURED BETWEEN 0.25 AND 0.30 MM FROM TERMINAL.
4. COPLANARITY APPLIES TO THE EXPOSED PAD AS WELL AS THE TERMINALS.
5. OUTLINE MEETS JEDEC DIMENSIONS PER MO-220, VARIATION VEED-6.

DIM	MILLIMETERS		
	MIN	NOM	MAX
A	0.800	0.900	1.000
A1	0.000	0.025	0.050
A3	0.200 REF		
b	0.180	0.250	0.300
D	3.00 BSC		
D2	1.250	1.40	1.550
E	3.00 BSC		
E2	1.250	1.40	1.550
e	0.500 BSC		
K	0.200	---	---
L	0.300	0.400	0.500

ON Semiconductor and  are registered trademarks of Semiconductor Components Industries, LLC (SCILLC). SCILLC reserves the right to make changes without further notice to any products herein. SCILLC makes no warranty, representation or guarantee regarding the suitability of its products for any particular purpose, nor does SCILLC assume any liability arising out of the application or use of any product or circuit, and specifically disclaims any and all liability, including without limitation special, consequential or incidental damages. "Typical" parameters which may be provided in SCILLC data sheets and/or specifications can and do vary in different applications and actual performance may vary over time. All operating parameters, including "Typicals" must be validated for each customer application by customer's technical experts. SCILLC does not convey any license under its patent rights nor the rights of others. SCILLC products are not designed, intended, or authorized for use as components in systems intended for surgical implant into the body, or other applications intended to support or sustain life, or for any other application in which the failure of the SCILLC product could create a situation where personal injury or death may occur. Should Buyer purchase or use SCILLC products for any such unintended or unauthorized application, Buyer shall indemnify and hold SCILLC and its officers, employees, subsidiaries, affiliates, and distributors harmless against all claims, costs, damages, and expenses, and reasonable attorney fees arising out of, directly or indirectly, any claim of personal injury or death associated with such unintended or unauthorized use, even if such claim alleges that SCILLC was negligent regarding the design or manufacture of the part. SCILLC is an Equal Opportunity/Affirmative Action Employer. This literature is subject to all applicable copyright laws and is not for resale in any manner.

PUBLICATION ORDERING INFORMATION

LITERATURE FULFILLMENT:

Literature Distribution Center for ON Semiconductor
P.O. Box 61312, Phoenix, Arizona 85082-1312 USA
Phone: 480-829-7710 or 800-344-3860 Toll Free USA/Canada
Fax: 480-829-7709 or 800-344-3867 Toll Free USA/Canada
Email: orderlit@onsemi.com

N. American Technical Support: 800-282-9855 Toll Free
USA/Canada

Japan: ON Semiconductor, Japan Customer Focus Center
2-9-1 Kamimeguro, Meguro-ku, Tokyo, Japan 153-0051
Phone: 81-3-5773-3850

ON Semiconductor Website: <http://onsemi.com>

Order Literature: <http://www.onsemi.com/litorder>

For additional information, please contact your local Sales Representative.